

SEASTAR™

SEAL REPLACEMENT KIT # HS5152 for Snap Ring Cylinders # HC5340 and HC5394

⚠ WARNING

Be careful not to scratch the metal end gland. Scratches could result in seal leaks and loss of steering.

⚠ WARNING

If scratches or grooves are present, the gland should be replaced. Contact your SeaStar Solutions representative for replacement end glands.

⚠ WARNING

Make sure no contamination is present on the end gland, especially on the seal surface. Contaminant's could result in seal leaks and loss of steering.

⚠ WARNING

Check new end glands for leaks.

This seal kit contains replacement seals for cylinders with snap ring type end glands only. If you have the screw in type end glands, you need to order SeaStar Solutions Seal Kit HS5157.

To replace the seals in the snap ring type end glands, proceed as follows:

- Remove the support brackets that connect the cylinder to the engines tilt tube.
- Remove and discard the snap rings using retaining ring pliers.
- Remove end glands. Hydraulic oil will leak out.
- Remove the three seals from each end gland using a dull object. See Warning.
- Inspect the end gland for scratches on the seal surfaces. See Warning.
- Clean the gland by washing in light oil or solvent. See Warning.
- Lubricate & install the new seals on the end gland in the positions shown on the drawing included with this kit. (items 5, 6, 9.)
- Remove the piston rod from the cylinder. Remove the old seal, then lubricate and install the new seal (item 7). Reinstall the piston rod in the cylinder, taking care not to damage the seal.
- Carefully slide the end glands over the piston rod and into the cylinder. Install the new snap rings. Make sure that the snap ring fully enters the groove in the cylinder.
- Reconnect the cylinder to the engine making sure all parts are returned to their original position and all nuts are tightened. Refer to the cylinder instructions.
- Re-purge the hydraulic cylinder and check the oil level in the helm pump. Additional hydraulic oil will be required. (SeaStar Solutions Part No. HA5430).
- Check for full travel of the cylinder and smooth operation.

Pressure Test & Inspection

Once the system is completely bled, turn the steering wheel at helm all the way to the hard over position (port or starboard) until the wheel stops and then force the wheel an extra 1/4–1/2 a revolution in the same direction until pressure relief is reached. (The helm pump may make a squeak or squeal sound as pressure relief is reached.)

Hold the helm/steering wheel in this position while all fittings and hose connections are checked to ensure there are no leaks. Repeat the procedure a second time in both directions to insure the hard over position is intact and there are no fitting leaks.

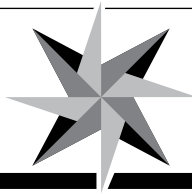

SEASTAR™ SEAL REPLACEMENT KIT # HS5152 for Snap Ring Cylinders # HC5340 and HC5394

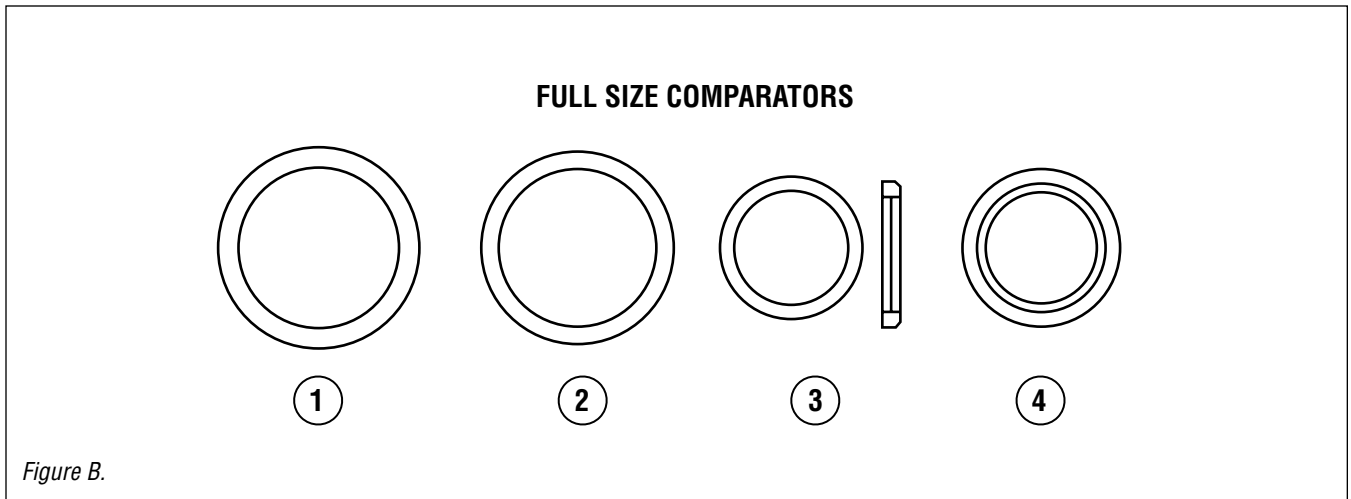
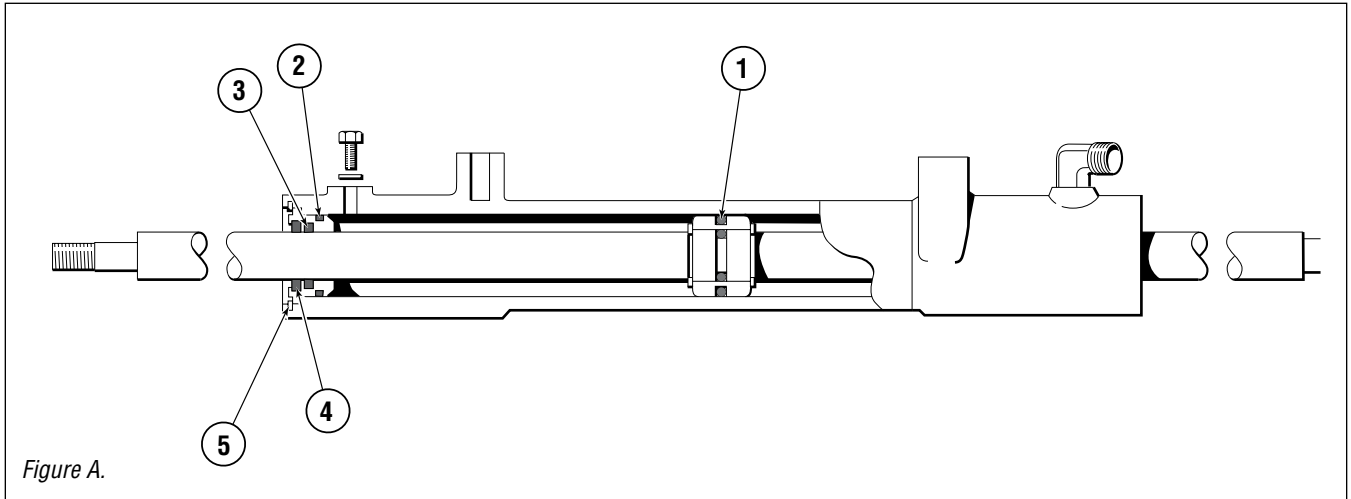

| ITEM | PART # | QTY | DESCRIPTION |
|------|--------|-----|----------------------------|
| 1 | 224628 | 1 | O-Ring |
| 2 | 008821 | 2 | O-Ring |
| 3 | 493526 | 2 | Quad Ring |
| 4 | 642921 | 2 | Wiper Ring |
| 5 | 271121 | 2 | Retainer Ring |
| *6 | 315827 | 1 | Copy FM Seal Kit Snap Ring |
| *7 | 438726 | 1 | Copy Seals FM Cylinder |

| ITEM | PART # | QTY | DESCRIPTION |
|------------------|--------|-----|--------------------------|
| *8 | 119629 | 1 | Lable SS 'Kit' Cardboard |
| *9 | 160322 | 1 | Bag Plastic 6 x 11 3 Mil |
| * Item Not Shown | | | |