



PURGE KIT # HA5457

SeaStar Power Steering

Kit Contains:

ITEM	PART #	QTY	DESCRIPTION
1	291021	1.5'	5/16" ID Clear Plastic Tubing
2	800111	2	Fitting Quick Disconnect
3	800116	2	Hose Clamp

NOTICE

Not all systems are exactly as shown.

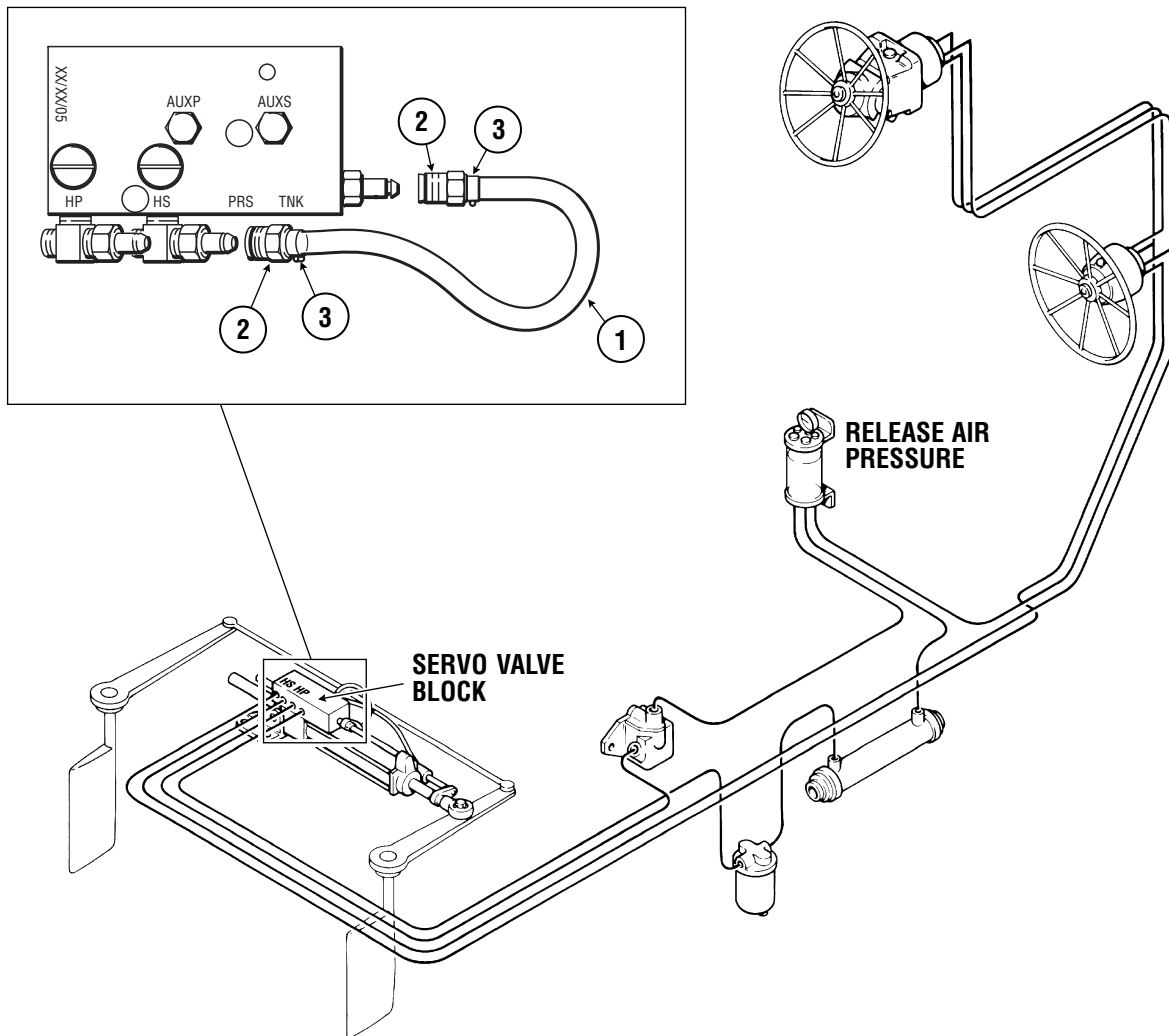

Figure A.



This kit provides an easy, cleaner way to pass fluid between the helm line, bleed fittings and the reservoir. With the bypass line installed, fluid and air from the bleeder is diverted to the reservoir. Included in this kit you will find a 1.05 foot length of 5/16" ID clear plastic tubing with quick connect fittings fitted to both ends.

- Step 1**
- Release the air pressure from the reservoir by pressing the air valve in.
 - Remove the reservoir fill plug and fill the reservoir to within an inch of the top.
- Step 2**
- Using a bicycle tire pump or similar device, pressurize the reservoir to 30 PSI. If necessary, refill and pressurize until the fluid level stabilizes at or above the Maximum level line on the reservoir.
 - Connect one end of the oil bypass line (Item 1) to the quick connect adapter on the servo valve block (figure A inset)
- Step 3**
- Go to helm station closest to the steering cylinder and turn the steering wheel clockwise until the cylinder shaft fully extends or retracts.
 - If rod is fully extended, attach the bypass line to the HS line on the cylinder servo block and open bleed fitting 3/4 of a turn. If rod is fully retracted, attach the bypass line to the HP line on the cylinder servo block and open bleed fitting 3/4 of a turn.
- Step 4**
- Move to the lowest helm station or the helm closest to the cylinder and begin turning the steering wheel counter clockwise at a one to two second per revolution pace.
 - Continue turning for approximately 80 revolutions.
 - Repeat this process at each successively higher station. If an autopilot is installed it should be treated as another helm unit except the motor is made to run continuously for at least 2 minutes in one direction.

NOTICE

Before continuing to a higher station, check the fluid level and air pressure in the reservoir. If the fluid level is below half, release the air pressure and refill to the maximum level line and pressurize the reservoir to between 25 and 30 PSI.

- Step 5**
- Close the cylinder bleed fitting and move the by-pass line to the second bleeder. Open the bleeder by turning loosening the bleeder nut 3/4 of a turn.
 - Return to the helm closest to the cylinder and turn the wheel counter clockwise until the cylinder moves to hard over in the opposite direction.
 - When the cylinder reaches hard over, begin turning in a clockwise direction for approximately 80 turns at a one to two second per revolution pace.
 - At each successively higher helm station, turn the wheel clockwise approximately 80 turns at a one to two second per revolution pace.
 - When finished, close the cylinder bleed fitting.



NOTICE

Before continuing to a higher station, check the fluid level and air pressure in the reservoir. If the fluid level is below half, release the air pressure and refill to the maximum level line and pressurize the reservoir to between 25 and 30 PSI.

Purging the Power Circuit

- With the power steering pump(s) running, turn one of the helm pumps from lock to lock approximately 20 times. If the pumps are engine driven, run the engines between 600 and 800 RPM for half the turns then increase the engine speed to about 1200 RPM.
- Check the fluid level in the reservoir. If it is less than half, release the air pressure, remove the filler plug and fill to the maximum line.
- Pressurize the reservoir to between 25 and 30 PSI.

NOTICE

If all the air is out of the system, when the reservoir is pressurized, the fluid level will remain stable. If the fluid level drops more than an inch and then stabilizes, the system should be purged a second time.