

MEMBER
ABYC[®]
Setting Standards for Safer Boating

51

ISO 9001

BayStar[™]

Capitano[™]

SeaStar[®]

Teleflex[®]
MARINE

MANUFACTURED BY
TELEFLEX CANADA LIMITED
PARTNERSHIP

INSTALLATION INSTRUCTIONS

AND OWNERS MANUAL

www.seastarsteering.com



SeaStar[®]

SeaStar Sport Tilt Helms

*Before you do it your way,
please try it our way*

Notice to Boat Manufacturer or Installer

Throughout this publication, Warnings and Cautions (accompanied by the International Hazard Symbol ⚠) are used to alert the manufacturer or installer to special instructions concerning a particular service or operation that may be hazardous if performed incorrectly or carelessly.

Observe Them Carefully!

These “safety alerts” alone, cannot eliminate the hazards that they signal. Strict compliance to these special instructions when performing the installation and maintenance plus “common sense” operation are major accident prevention measures.

⚠ DANGER	⚠ WARNING	⚠ CAUTION	NOTICE
Immediate hazards which WILL result in severe personal injury or death.	Hazards or unsafe practices which COULD result in severe personal injury or death.	Hazards or unsafe practices which COULD result in minor injury or product or property damage.	Information which is important to proper installation or maintenance, but is not hazard-related.

⚠ WARNING

Cleaning fluids containing ammonia, acids or any other corrosive ingredients **MUST NOT** be used for cleaning any part of this Hydraulic Steering System. Failure to comply will cause serious damage to the steering system, resulting in possible loss of steering, causing property damage, personal injury and/or death.

Don't compromise performance... use genuine SeaStar parts only!

- SeaStar helms
- SeaStar hoses
- SeaStar Cylinders
- SeaStar Oil

Substituting non SeaStar parts in any part of the SeaStar hydraulic steering system, may seriously compromise system performance.

SAFETY INFORMATION

⚠ WARNING

The safety information provided below is intended to inform you of the dangers that may be present before, during and after the installation. It is critical that you read and understand ALL the points noted.

The safe operation of the steering system is dependant upon proper installation and maintenance, common sense, safe judgment and the knowledge/expertise of the operator. Every installer/user of the steering system should know the following requirements 'before' installing/using the steering system.

If you have any questions regarding any of these warnings, contact Teleflex Marine.

To reduce risk of severe injury or death. Always wear a Coast Guard Approved personal flotation device (PFD) and use an engine shut-off cord (lanyard).

Before installation

1. Read and understand the Installation and Owner's Manuals provided with your steering components.
2. Ensure that all components required to complete the installation are on hand (including hoses, fittings, oil and the proper tools required for the installation).
3. SeaStar components are highly engineered and safety tested to ensure system integrity, DO NOT substitute any component with non-SeaStar components as this may compromise system performance/reliability.

Installation

1. Install components as directed in all Installation Manuals (including helm pumps, hoses and fitting kits).
2. DO NOT modify or substitute any component in any way without written consent from Teleflex Marine.
3. Comply with all system ratings/regulations (boat/engine, U.S.C.G.).
 - Cylinder MUST be compatible with engine(s)/rudder(s) and/or outdrive(s) installed.
 - Cylinder MUST be rated for use on the engine(s) installed (outboard applications).
4. Confirm that there is no interference between the steering cylinder(s), tiebars and the transom, splashwell, outboard engine or jackplate or any combination of these parts by performing the following steps;
 - a) With engine fully tilted DOWN, turn steering wheel from hard over to hard over and confirm that no interference occurs.
 - if using a hydraulic jack plate the above must also be performed at all the positions of the jack plate.
 - b) Repeat step 4a) with engines tilted UP.
 - c) Perform step 4a) with each engine in DOWN/UP positions confirming that independent TRIM/TILT can be done without any interference.
5. Confirm that the steering cylinder can be fully stroked in both directions as well as full tilt and trim without stretching, chafing, rubbing and/or kinking of the hydraulic hoses.
6. Confirm that extruded nylon tubing has NOT been substituted for SeaStar Steering Hose. Outboard applications only.
7. DO NOT use a wire coil type trim switch with a hydraulic steering system as the wire can wind up tight around the steering wheel shaft and prevent further steering.
8. Conduct Oil Level and System Check as outlined in your steering cylinder manual.

Safety Information Continued

⚠ WARNING

The safety information provided below is intended to inform you of the dangers that may be present before, during and after use. It is critical that you read and understand **ALL** the points noted.

Prior to every use

1. Check Fluid level in highest helm pump (refer to your steering cylinder manual for proper fluid level setting).
2. Verify immediate steering response when turning steering wheel(s). (Ensure engine turns when steering wheel is turned.)
3. Visually inspect all steering hoses and fittings for wear, kinking and/or leaks.
4. Check for binding, loose, worn or leaking steering components.

DO NOT OPERATE BOAT IF ANY COMPONENT IS NOT IN PROPER WORKING CONDITION.

During use

1. WEAR A COAST GUARD-APPROVED PERSONAL FLOTATION DEVICE (PFD).
2. ATTACH ENGINE SHUT-OFF CORD (LANYARD) TO YOUR PDF.
3. Never allow anyone not familiar with the operation of the steering system operate the boat at any time.
4. Know and adhere to the operator restrictions for your area including;
 - Federal Laws/Regulations,
 - State Laws/Regulations and
 - Municipal Laws/Regulations.

DO NOT OPERATE BOAT IF ANY COMPONENT IS NOT IN PROPER WORKING CONDITION.

After use

1. Rinse off steering system thoroughly using 'fresh, clean water only'.
 - Cleaning fluids containing ammonia, acids or any other corrosive ingredients **MUST NOT** be used for cleaning any part of the hydraulic steering system.

Maintenance

1. Maintain steering system at a minimum of twice per year.
 - See Maintenance section in your steering cylinder manual.

Keep our waters clean for all current and future users. Dispose of ALL fluids in accordance with your local regulations.

INTRODUCTION

The SeaStar Steering System is the smoothest and most efficient hydraulic steering system available today. They have been designed for normal pleasure and commercial use where standard rigging arrangements are used. Before proceeding with the installation of this tilt helm, read these instructions thoroughly. Teleflex Marine cannot accept responsibility for installation where instructions have not been followed, where substitute parts have been used, or where modifications have been made to our products.

This Installation and Owner's Manual covers ALL SeaStar, Sport and Sport Plus Tilt helms. Any differences between the helms will be noted where required.

NOTICE

Due to a small amount of internal oil slip, a “master spoke” or “centered” steering wheel (such as those used in automobiles) will not maintain a straight ahead wheel setting. For best results, use an “equal distance spoke” steering wheel.

NOTICE

Help protect your boating environment by ensuring that all used oil is disposed of properly.

Index

Safety Information.....	i
Introduction	1
System Installation Overview	2
Tilt Helm Template	3
Sport Tilt Helm Mounting	5
Sport Tilt Helm Installation	6
Sport Plus Tilt Helm Mounting	7
Sport Plus Tilt Helm Installation	8
Remote Fill & Vent Kit Installation	9
Troubleshooting Guide	10
Warranty policy/procedures	11

To assist in future troubleshooting, note your helm pump part number here:

HH_____.

SYSTEM INSTALLATION OVERVIEW

STEP 1 STEERING CYLINDER INSTALLATION:

Install your steering cylinder as per the Installation manual provided with your cylinder.



STEP 2 TILT HELM INSTALLATION:

Install your Tilt Helm as per the detailed installation instructions on pages 6–7 of this manual,

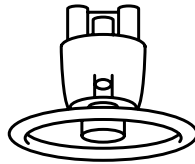

STEP 3 REMOTE FILL AND VENT KIT INSTALLATION:

Using page 8 In this manual, install the helm fill and vent kit

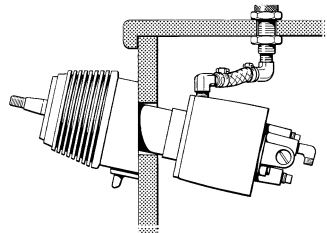

Step 4 FILLING AND PURGING OF STEERING SYSTEM:

Using the Fill and Purge instructions provided in your steering cylinder manual, fill and purge the steering system.

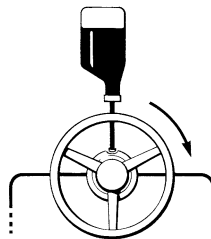

Step 5 OIL LEVEL AND SYSTEM CHECK:

Using the “Oil level and system checks” provided in your steering cylinder manual, confirm proper operation of your steering system.

TILT HELM TEMPLATE

Tilt Helm Mounting Template

NOTICE

If you must photocopy this mounting template for use, check ALL measurements using a measuring device prior to using as a template.

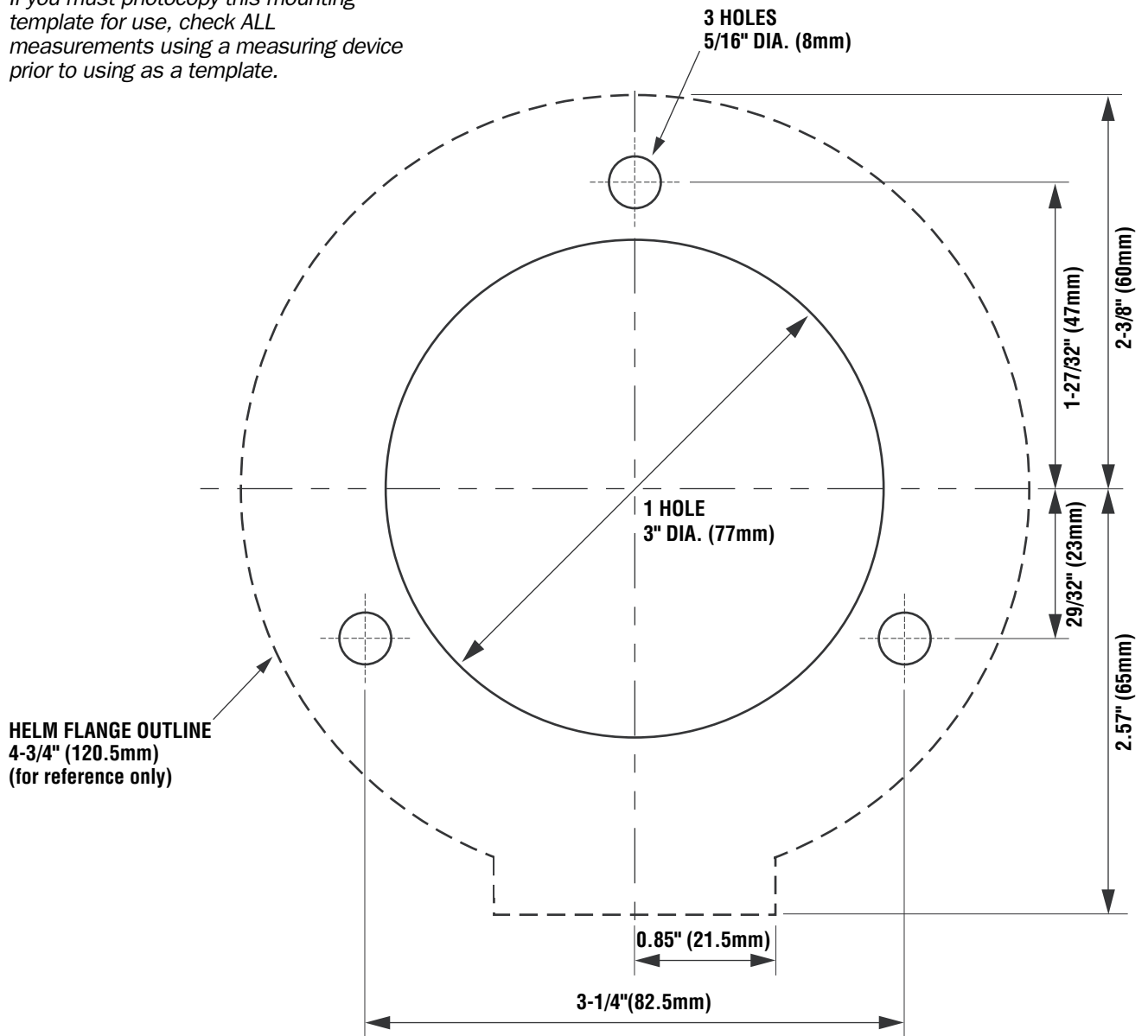

SPORT TILT HELM MOUNTING

⚠ WARNING

Use the self-locking fasteners provided **ONLY**; substituting non-self locking fasteners can result in loosening or separation of equipment leading to loss of steering control causing property damage and/or personal injury.

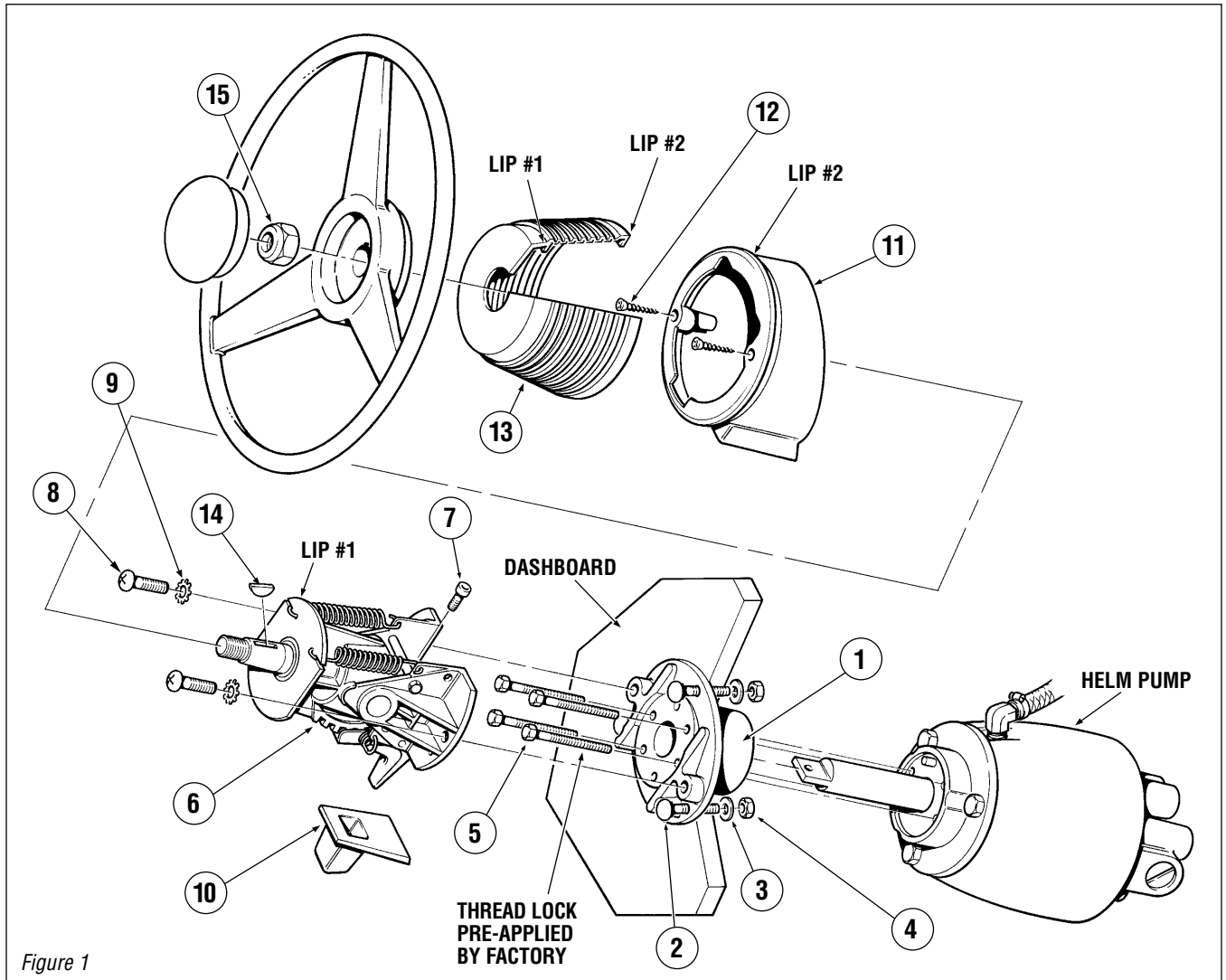

Figure 1

ITEM	PART #	QTY	DESCRIPTION
1	279068	1	Tilt Plate
2	954829	3	CB 1/4" NC x 2"
3	201429	3	Washer, 1/4" Flat SS
4	067424	3	Nut, 1/4" NC, Nyloc®
5	007279	4	HHCS 1/4" NC x 2-1/2" SS
6	279021	1	Tilt Mechanism
7	757927	1	SCHS #10-24 x 7/8" SS
8	958627	2	PHMS 5/16" NC x 3/4"

ITEM	PART #	QTY	DESCRIPTION
9	957725	2	Washer, Star
10	157616	1	Boot Latch
11	157477	1	Bezel, Lower
12	952623	2	#8-32 x 1"
13	157512	1	Below
14	260130	1	Shaft Key
15	747521	1	Wheel Shaft Nut

Sport Tilt Helm Installation

⚠ WARNING

Use self-locking fasteners provided **ONLY**; substituting non-self locking fasteners can result in loosening or separation of equipment leading to loss of steering control causing property damage and/or personal injury. **DO NOT** exceed **110 in.lb. (12Nm)** torque on helm nuts and bolts.

NOTICE

If the helm pump shaft is difficult to locate into the tilt mechanism coupling, loosen the TOP screw in the coupling by NO MORE than 1/4 of a turn. Ensure that this screw is fully tightened before installing the bezel.

STEP 1. Using the template provide on page 3. Confirm that the location of the Tilt Helm will allow unrestricted operation of the steering wheel in **ALL** tilting positions and will **NOT** interfere with other functional equipment.

STEP 2. Tape the template to the dash and use a center punch for locating the holes on the dash. Double check to ensure unrestricted operation of the steering wheel in **ALL** tilting positions.

STEP 3. Drill the required diameter center hole and the specified number and size of mounting bolts as shown in the template.

STEP 4. Mount Tilt Plate (Item 1) to the dash using the three 1/4" NC x 2" carriage bolts (Item 2), washers (Item 3) and self locking nuts (Item 4)

STEP 5. Prior to mounting helm pump to the dash plate, install desired fittings into the rear of the helm pump using Teflon based pipe sealant. **DO NOT** use Teflon Tape, **ONLY** use paste style Teflon based pipe sealant.

STEP 6. Mount the helm pump from behind the dash to the tilt mounting plate (Item 1) so that the four helm mounting holes align with the applicable holes in the tilt mounting plate. Apply a small amount of the supplied Loctite® on ALL four of the 1/4 x 2-1/2" hex head bolts (Item 5) and secure them to the helm pump.

STEP 7. Attach the helm shaft to the tilt mechanism (Item 6) by lining up the coupling slot with the helm shaft tongue and secure with the no. 10 - 24 x 7/8" (Item 7).

STEP 8. Tighten the two PHMS 5/16" NC x 3/4" screws (Item 8), and star washers (Item 9) to secure the tilt mechanism to the dash plate.

STEP 9. Install boot latch (Item 10) onto the tilt latch of tilt mechanism.

STEP 10. Position the tilt unit in the middle position and mount the lower bezel (Item 11) to the tilt mechanism ensuring that the boot latch (Item 10) is held into the slots provided in the lower bezel (Item 11). Secure the bezel with the two PHMS #8-32 x 1" (Item 12).

STEP 11. Install boot cover (Item 13) over lip 1 of the tilt mechanism and around lip 2 of the lower bezel. (shown in Figure 1).

STEP 12. Grease steering shaft with a good quality marine grease.

STEP 13. Install woodruff key (Item 14) and wheel shaft nut (Item 15). Tighten wheel shaft nut prior to continuing on with instructions. Torque wheel shaft nut to 150 in/lb, **DO NOT** exceed 200 in.lb.

STEP 14. Confirm proper function of the tilt mechanism:

- Push the tilt latch forward to unlock the tilt mechanism
- Check ALL positions of the tilt and confirm that the latch locks in place for each position, tilt lever will click back into the locked position.

STEP 15. ONLY if the tilting function is confirmed to function, continue to page 8 for remote fill kit installation.

SPORT PLUS TILT HELM MOUNTING

⚠ WARNING

Use the self-locking fasteners provided **ONLY**; substituting non-self locking fasteners can result in loosening or separation of equipment leading to loss of steering control causing property damage and/or personal injury.

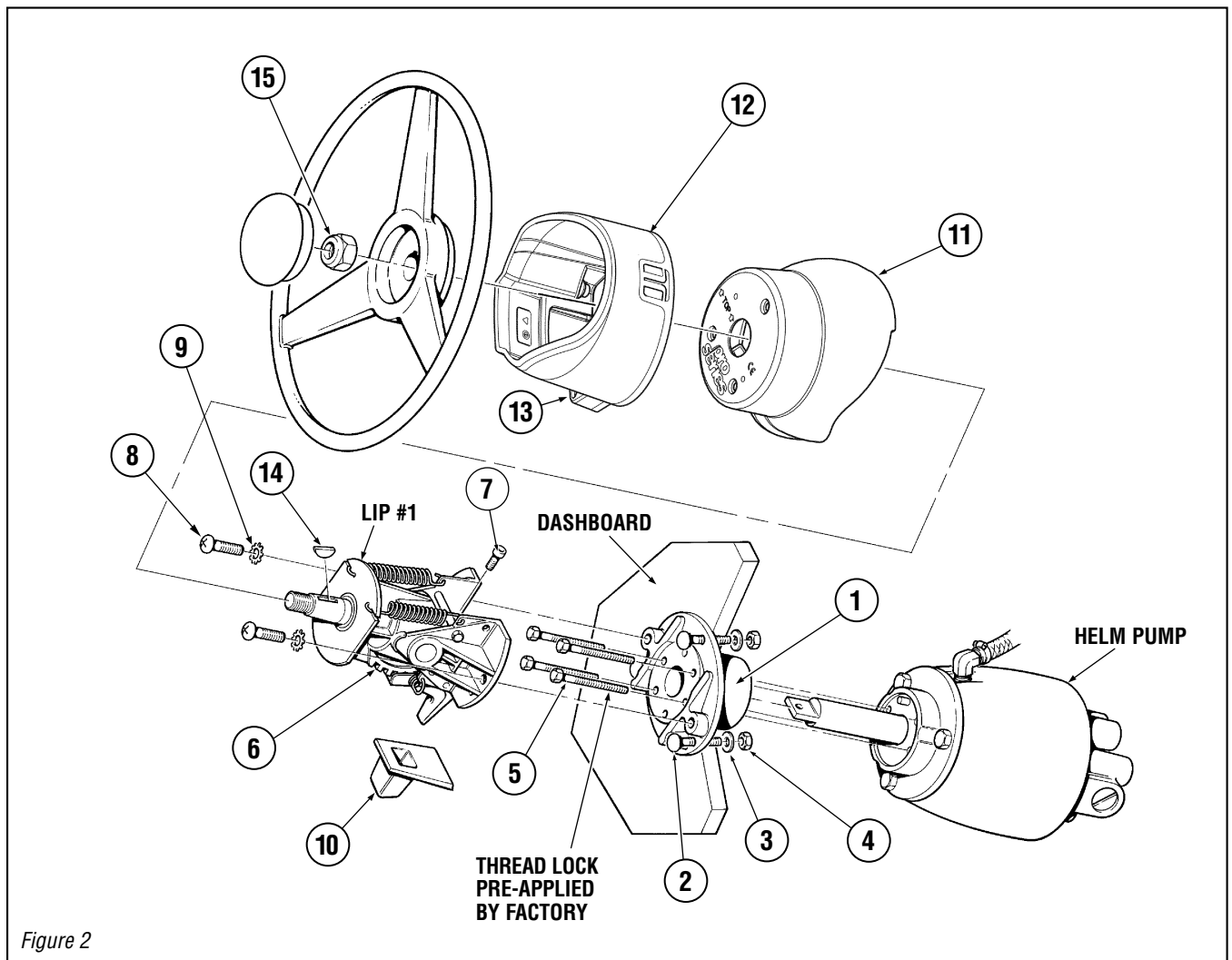

ITEM	PART #	QTY	DESCRIPTION
1	279064	1	Tilt Plate
2	984829	3	CB 1/4" NC x 2"
3	201429	3	Washer 1/4" Flat SS
4	067424	3	Nut, 1/4" NC, Nyloc®
5	007279	4	HHCS 1/4" NC x 2-1/2" SS
6	182110	1	Tilt Mechanism
7	757927	1	SCHS #10-24 x 7/8" SS
8	958627	2	PHMS 5/16" NC x 3/4"

ITEM	PART #	QTY	DESCRIPTION
9	957725	2	Washer, Star
10	279049	1	Latch Boot
11	279041	1	Upper Bezel
12	279045	1	Lower Bezel
13	279082	5	BHSCS 8-32 x 1/2" SS
14	260130	1	Shaft Key
15	747521	1	Wheel Shaft Nut

Sport Plus Tilt Helm Installation

STEP 1 Using the template provided on page 3. Confirm that the location of the helm will allow unrestricted operation of the steering wheel in **ALL** tilting positions and will **NOT** interfere with any other functional equipment.

STEP 2 Tape the template to the dash and use a center punch for locating the holes on the dash. Double check to ensure unrestricted operation of the steering wheel in **ALL** tilting positions.

STEP 3 Drill required diameter center hole and the specified number and size of the mounting bolts as shown in the template.

STEP 4 Mount Tilt plate (Item 1) to the dash using the three 1/4" NC x 2" carriage bolts (Item 2, washers (Item 3) and self locking nuts (item 4). Torque to 110 in/lb.

STEP 5 Prior to mounting the helm pump to the dash plate, install desired fittings into the rear of the helm pump using a Teflon Based pipe sealant. **DO NOT** use Teflon tape, **ONLY** use a paste style Teflon based pipe sealant.

STEP 6 Mount the helm pump from behind the dash to the tilt mounting plate (Item 1) so that the four helm mounting holes align with the applicable holes in the tilt mount plate. Install the four 1/4" x 2-1/2" hex head bolts (Item 5) and secure them to the helm pump. Torque to 110 in/lb.

STEP 7 Attach the helm shaft to the tilt mechanism (Item 6) by lining up the coupling slot with the helm shaft tongue and secure with the one 10-24 NC x 7/8" bolt (Item 7). Torque to 20-24 in/lb.

STEP 8 Install and tighten the two PHMS 5/16" NC x 3/4" screws (Item 8) and the star washers (Item 9) to secure the tilt mechanism to the dash plate. Torque to 160-180 in/lb.

STEP 9 Install the boot latch (Item 10) onto the tilt latch of the tilt mechanism.

STEP 10 Fit the upper bezel (Item 11) into the lower bezel (Item 12) and position two parts over the tilt mechanism. Install the 5 x BHSCS 8-32 x 1/2" SS (Item 13) screws into the position show.

STEP 11 Grease steering shaft with good quality marine grade grease.

STEP 12 Install the woodruff key (Item 14) and wheel shaft nut (Item 15), Tighten steering wheel shaft nut prior to continuing with installation instructions. Torque wheel shaft nut to 150 in/lb.

DO NOT exceed 200 in/lb.

STEP 13 Confirm proper function of the tilt mechanism using the following points.

Push tilt latch forward to 'unlock' the tilt mechanism.

Check **ALL** positions of the tilt and confirm that the latch 'locks' in place for each position, tilt lever will click back into the locked position.

STEP 14 ONLY if the tilting function is confirmed to function, continue with the 'Remote Fill and Vent Installation' as shown in the installation manual included with the helm pump.

NOTICE

*If the helm pump shaft is difficult to locate into the tilt mechanism coupling, loosen the TOP screw in the coupling by **NO MORE** than 1/4 of a turn. Ensure that this screw is fully tightened before installing the bezels.*

NOTICE

Ensure that tilt latch boot (Item 10) is properly fitted into the slots provided in the lower bezel.

Remote Fill & Vent Kit Installation

Remote Fill & Vent

This kit will provide means to fill and vent the steering system above the dash or consul. A 3/4" hole will need to be drilled into the dash/consul **ABOVE** the helm pump, prior to drilling any holes, confirm that you will not drill into any functioning equipment.

1. Locate desired location for placement of the helm fill plug onto of the dash/consul. Look beneath the dash/consul to confirm that there is sufficient space for the fill hose and fittings. Confirm that there is no interference with any other equipment. Mark the location and drill a 3/4" hole from above or below the dash/consul.
2. Apply a Teflon based pipe sealant to the threads of the elbow fitting going into the helm pump, **DO NOT** use Teflon Tape, **ONLY** use the paste type pipe sealant. Screw one of the elbow barb fittings into the applicable helm filling port.

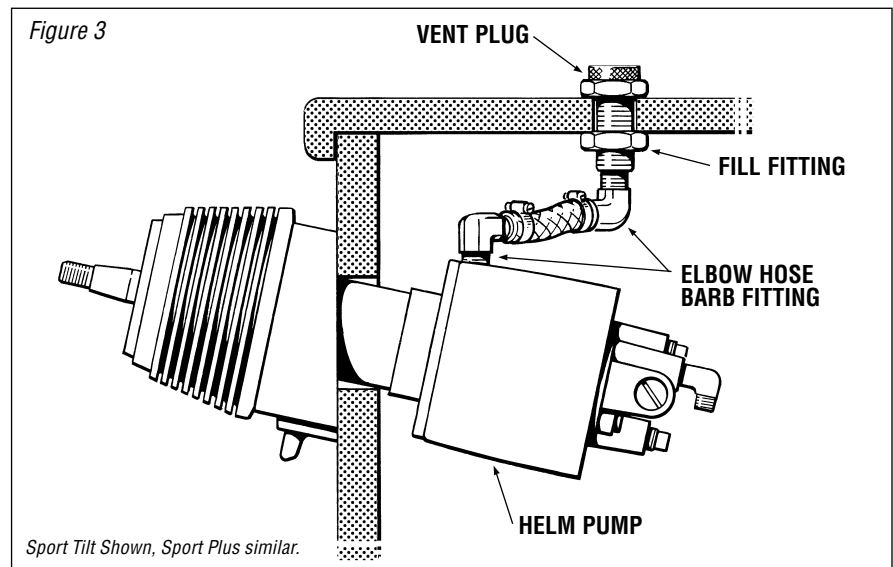

3. Attach the vinyl tubing to the elbow fitting that you just installed into the helm pump and secure with a hose clamp. A small amount of oil inside the vinyl tube will help slide it onto the elbow barb fitting.
4. Insert fill fitting from the top of the dash/consul and secure with the jam nut.

NOTICE

A spacer may be required if mounting surface is less than 3/8" thick, this spacer is provided in this kit

5. Apply Teflon based pipe sealant to the threads of the elbow fitting that will be installed into the fill fitting. **DO NOT** use Teflon Tape; **ONLY** use the paste type pipe sealant.
6. Vinyl hose **MUST** have a gradual rise from the helm fitting to the fill fitting to allow air to rise. Cut vinyl tube to the required length and secure to the fill fitting with a hose clamp.

TROUBLESHOOTING GUIDE

FAULT	CAUSE	SOLUTION
1. Cannot get helm shaft to go into U-Joint.	U-Joint bolt is too tight.	Loosen the "Top" bolt no more than 1/4" to allow the Helm shaft to be installed.
2. Tilt will not lock into place.	Spring has come undone. Or a broken Tilt tooth.	Re-attach spring. Replace Tilt mechanism.
3. Fluid is leaking from where the elbow fitting is installed into the Helm pump fill port.	No pipe sealant installed onto threads. Hose clamp not tightened down.	Re-apply Teflon® based pipe sealant, NO TEFLON® TAPE. Tighten hose clamp fully.
4. Wheel is really hard to turn in both directions.	Tilt boot is rubbing on the steering wheel hub.	Confirm that the rubber boot is installed over both lips and is NOT rubbing on the wheel hub.
5. Cannot remove steering wheel.	Seized in place. No grease applied to shaft before wheel installation.	Using your knee under the wheel and your hand on top, with the wheel shaft nut installed one turn on shaft, lightly tap helm shaft to release wheel.

Statement of Limited Warranty

We warrant to the original retail purchaser that **Teleflex Canada Limited Partnership** products have been manufactured free from defects in materials and workmanship. This warranty is effective for two years from date of purchase, excepting that where **Teleflex Canada Limited Partnership** products are used commercially or in any rental or income producing activity, then this warranty is limited to one year from the date of purchase.

We will provide replacement product without charge, for any **Teleflex Canada Limited Partnership** product meeting this warranty, which is returned (freight prepaid) within the warranty period to the dealer from whom such product were purchased, or to us at the appropriate address. In such a case **Teleflex Canada Limited Partnership** products found to be defective and covered by this warranty, will be replaced at **Teleflex's** option, and returned to the customer.

The above quoted statement is an extract from the complete **Teleflex Canada Limited Partnership** products warranty statement. A complete warranty policy is available in our **Teleflex Canada Limited Partnership** products catalogue.

Return Goods Procedure

Prior to returning product to **Teleflex Canada Limited Partnership** under warranty, please obtain a *Return Goods Authorization number* (claim number).

Be sure to label the goods with:

- a) the name and address of the sender, and
- b) the return goods authorization number (claim number)

Please address the returned goods as follows:

From U.S.A.

RGA # ?

Teleflex Canada Limited Partnership
c/o UPS-Supply Chain Solutions Inc.
Door A37
1201 C Street NW
Auburn, WA, 98001

From Canada

RGA # ?

Teleflex Canada
3831 No.6 Road
Richmond, B.C.
Canada V6V 1P6

Teleflex®

MARINE

TELEFLEX CANADA
3831 NO.6 ROAD
RICHMOND, B.C.
CANADA V6V 1P6

FAX 604-270-7172

www.seastarsteering.com

ISO 10592



© 2006 TELEFLEX CANADA LIMITED PARTNERSHIP

PRINTED IN CANADA

FORM NO. 279102

04/11 Rev. F