

MEMBER
ABYC
Setting Standards for Safer Boating

40

FORTY
ISO 9001

BAYSTAR[™]

CAPILANO[™]

SEASTAR[™]

OPERATING INSTRUCTIONS

AND OWNER'S MANUAL

www.seastarsolutions.com



SEASTAR[™]

Autopilot Pump



SEASTAR
SOLUTIONS[®]



*Before you do it your way,
please try it our way*

Notice to Boat Manufacturer or Installer

Throughout this publication, Warnings and Cautions (accompanied by the International Hazard Symbol ) are used to alert the manufacturer or installer to special instructions concerning a particular service or operation that may be hazardous if performed incorrectly or carelessly.

Observe Them Carefully!

These “safety alerts” alone, cannot eliminate the hazards that they signal. Strict compliance to these special instructions when performing the installation and maintenance plus “common sense” operation are major accident prevention measures.

 DANGER	 WARNING	 CAUTION	NOTICE
Immediate hazards which WILL result in severe personal injury or death.	Hazards or unsafe practices which COULD result in severe personal injury or death.	Hazards or unsafe practices which COULD result in minor injury or product or property damage.	Information which is important to proper installation or maintenance, but is not hazard-related.

WARNING

Cleaning fluids containing ammonia, acids or any other corrosive ingredients MUST NOT be used for cleaning any part of this Hydraulic Steering System. Failure to comply will cause serious damage to the steering system, resulting in possible loss of steering, causing property damage, personal injury and/or death.

NOTICE

Help protect your boating environment by ensuring that all used oil is disposed of properly.

NOTICE

Marine Canada Acquisition Inc. DBA SEASTAR SOLUTIONS is referred to as SeaStar Solutions throughout this publication.

Don't compromise performance... use genuine SeaStar parts only!

- SeaStar helms
- SeaStar cylinders
- SeaStar hoses
- SeaStar oil

Substituting non SeaStar parts in any part of the SeaStar hydraulic steering system, may seriously compromise system performance.

SAFETY INFORMATION

WARNING

The safety information provided below is intended to inform you of the dangers that may be present before, during and after the installation. It is critical that you read and understand ALL the points noted.

The safe operation of the steering system is dependant upon proper installation and maintenance, common sense, safe judgment and the knowledge/expertise of the operator. Every installer/user of the steering system should know the following requirements 'before' installing/using the steering system.

If you have any questions regarding any of these warnings, contact SeaStar Solutions.

To reduce risk of severe injury or death. Always wear a Coast Guard Approved personal flotation device (PFD) and use an engine shut-off cord (lanyard).

Before installation

1. Read and understand the Installation and Owner's Manuals provided with your steering components.
2. Ensure that all components required to complete the installation are on hand (including hoses, fittings, oil and the proper tools required for the installation).
3. SeaStar components are highly engineered and safety tested to ensure system integrity, DO NOT substitute any component with non-SeaStar components as this may compromise system performance/reliability.

Installation

CAUTION

-3 steering cylinders are fitted with ORB hose fittings. DO NOT use NPT fittings, irreparable damage to cylinder WILL occur.

1. Install components as directed in all Installation Manuals (including helm pumps, hoses and fitting kits).
2. DO NOT modify or substitute any component in any way without written consent from SeaStar Solutions.
3. Comply with all system ratings/regulations (boat/engine, U.S.C.G.).
 - Cylinder MUST be compatible with engine(s) installed.
 - Cylinder MUST be rated for use on the engine(s) installed.
4. Confirm that there is no interference between the steering cylinder(s), tiebars and the transom, splashwell, outboard engine or jackplate or any combination of these parts by performing the following steps;
 - a) With engine fully tilted DOWN, turn steering wheel from hard over to hard over and confirm that no interference occurs.
 - if using a hydraulic jack plate the above must also be performed at all the positions of the jack plate.
 - b) Repeat step 4a) with engines tilted UP.
 - c) Perform step 4a) with each engine in DOWN/UP positions confirming that independent TRIM/TILT can be done without any interference.
5. Confirm that the steering cylinder can be fully stroked in both directions as well as full tilt and trim without stretching, chafing, rubbing and/or kinking of the hydraulic hoses.
6. Confirm that extruded nylon tubing has NOT been substituted for SeaStar Steering Hose.
7. DO NOT use a wire coil type trim switch with a hydraulic steering system as the wire can wind up tight around the steering wheel shaft and prevent further steering.
8. Conduct System Check as outlined on page 20 of this manual.

WARNING

The safety information provided below is intended to inform you of the dangers that may be present before, during and after use. It is critical that you read and understand ALL the points noted.

Prior to every use

1. Check Fluid level in highest helm pump (see page 15 for proper fluid level setting).
2. Verify immediate steering response when turning steering wheel(s). (Ensure engine turns when steering wheel is turned.)
3. Visually inspect all steering hoses and fittings for wear, kinking and/or leaks.
4. Check for binding, loose, worn or leaking steering components.

DO NOT OPERATE BOAT IF ANY COMPONENT IS NOT IN PROPER WORKING CONDITION.

During use

1. WEAR A COAST GUARD-APPROVED PERSONAL FLOTATION DEVICE (PFD).
2. ATTACH ENGINE SHUT-OFF CORD (LANYARD) TO YOUR PFD.
3. Never allow anyone not familiar with the operation of the steering system operate the boat at any time.
4. Know and adhere to the operator restrictions for your area including;
 - Federal Laws/Regulations,
 - State Laws/Regulations and
 - Municipal Laws/Regulations.

DO NOT OPERATE BOAT IF ANY COMPONENT IS NOT IN PROPER WORKING CONDITION.

After use

1. Rinse off steering system thoroughly using 'fresh, clean water only'.
 - Cleaning fluids containing ammonia, acids or any other corrosive ingredients **MUST NOT** be used for cleaning any part of the hydraulic steering system.

Maintenance

1. Maintain steering system at a minimum of twice per year.
 - See Maintenance, on page 21 of this manual.

Keep our waters clean for all current and future users. Dispose of ALL fluids in accordance with your local regulations.

INTRODUCTION

Before proceeding with the installation, read these instructions thoroughly to familiarize yourself with the workings of the SeaStar Autopilot pump. SeaStar Solutions cannot accept responsibility for installations where instructions have not been followed, where substitute parts have been used, or, where modifications have been made to our products. Warranty may be void if products other than SeaStar Solutions products are used with this system.

Index

Safety Information	i
Introduction	1
Before Operating Your Boat	2
Things You Need To Know!.....	3
SeaStar Autopilot Pump Compatibility	4
Specifications	5
System Installation	6
Before Starting.....	6
Tools	6
Overview	7
Step 1 Mounting and Plumbing	8
Step 2 Autopilot Electrical Connections	12
Step 3 Filling & Purging the System.....	13
Step 3.1 Fill & Purge Manually.....	15
Step 3.2 Fill & Purge Using Power Purge	18
Step 3.3 Additional Purge Instructions.....	19
Step 4 System Check.....	20
Maintenance	21
Troubleshooting Guide	22
Statement of Limited Warranty	23
Return Goods Procedure	23
Mounting Template	25

BEFORE OPERATING YOUR BOAT

Ensure that the following check list is carried out.

1. With the Autopilot pump turned OFF (ignition OFF) perform a system pressure test by turning the wheel all the way to hard over and then forcing the wheel another one quarter to one half turn past the stop point.

Inspect the following areas:

- Inspect helm fittings
- Inspect Power Assist/Autopilot interface (if installed) and Autopilot pump fittings
- Inspect cylinder and cylinder bleed fittings
- Inspect hoses

Look for evidence of a leak. This test is to be completed in BOTH directions. ANY leak that is noticed MUST be corrected prior to operation of the boat.

2. **Confirm that extruded nylon tubing has NOT been substituted for SeaStar/SeaStar PRO Hydraulic Steering Hoses.**
3. Confirm that there is no interference between the steering cylinder and the transom, splashwell or jack plate or any combination of these parts by performing these simple steps:
 - If installed on an outboard engine, with the engine fully tilted, turn steering from hard over to hard over and confirm that NO interference occurs. If you are using a hydraulic jack plate this step must also be performed at the top and bottom position of the jack plate. If interference is present, it MUST be eliminated with trim limiting switches and/or jack plate restrictors. Contact jack plate manufacturer for advice if required.
 - Confirm that the steering cylinder can be stroked fully in both directions as well as full tilt and trim without stretching and/or kinking the hydraulic hoses.
 - Confirm that the hydraulic hoses are not subjected to chafing or rubbing.

WARNING

Failure to comply with the above may result in loss of steering causing property damage and/or personal injury or death.

Things You Need To Know!

⚠ WARNING

SeaStar/SeaStar PRO Steering hoses **CANNOT** be cut. Cutting these hoses will render them useless. Failing to comply may result in possible loss of steering causing property damage, personal injury and/or death.

⚠ CAUTION

DO NOT use SeaStar nylon tubing with the Autopilot pump, other than for the compensating line. Use of SeaStar/ SeaStar PRO steering hose is the **ONLY** hose recommended for use in these systems.

⚠ WARNING

Stretched, kinked or chafed hose will fail over a period of time. Check hoses frequently to avoid potential loss of steering causing property damage and/or personal injury or death.

⚠ CAUTION

Take **EXTREME** care not to allow any foreign material or contaminant to enter the hydraulic steering system. Contamination is the main cause of hydraulic system wear and/or failure. Keep protective caps on hose ends until ready to thread onto a fitting.

⚠ CAUTION

Confirm that **ALL** components needed to complete the installation are purchased, including helm pump, steering cylinder, hoses, fluid, fittings and pipe sealant such as Loctite® PST. **NEVER USE TEFLON TAPE, ONLY USE A LIQUID, TEFLON BASED PIPE SEALANT.**

⚠ WARNING

If installed in a system that does **NOT** have a SeaStar helm, an external pressure relief valve set at **1000psi MAX**, such as Part # **HA5822** or equivalent, **MUST** be installed.

NOTICE

If retrofitting onto an existing SPA installation a HA1205 retrofit kit will be required.

⚠ WARNING

When working in an area where fumes from fuel are present, allow the fumes to disperse completely **BEFORE** doing any electrical connections of any kind. Failure to do so may result in an explosion or fire.

SeaStar Autopilot Pump Compatibility

The SeaStar Autopilot pump is designed for use in recreational marine applications, in conjunction with SeaStar Hydraulic Steering Systems. It is a fixed flow, reversible pump-set that uses a high efficiency gear pump, producing very little vibration or noise. It is offered in 12 and 24 volt configurations, as well as two different pump outputs (type 1 and type 2). It can be used as a standalone Autopilot pump or can be mounted to a previously installed SeaStar Power Assist unit avoiding the need to install additional hydraulic lines.

Optimal performance will be attained when used with SeaStar helm pumps and other genuine SeaStar components, such as; SeaStar Hoses and SeaStar Steering Cylinders.

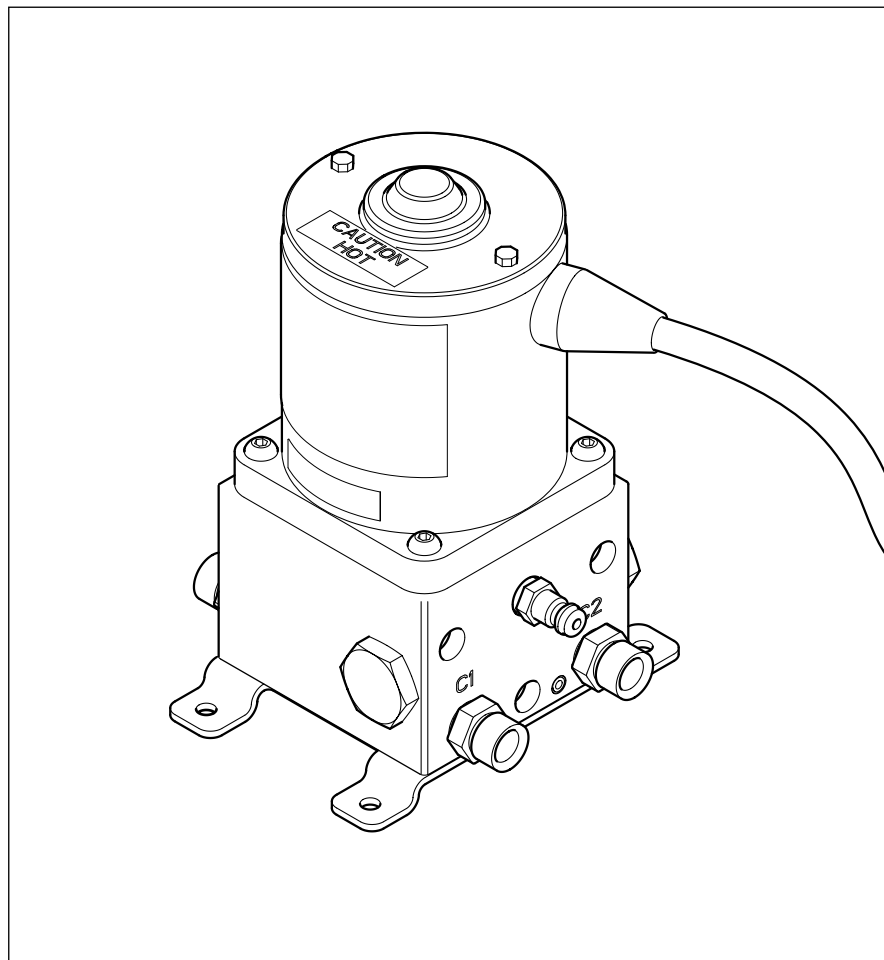

Figure 1.

! WARNING

SeaStar extruded nylon tubing may ONLY be used for the compensating line. DO NOT use SeaStar extruded nylon tubing ANYWHERE else within the system.

SPECIFICATIONS

! WARNING

DO NOT exceed peak operating pressure. 1000psi.

12V SEASTAR AUTOPILOT PUMP

- 12 Volts
- 1000psi MAX system pressure
- Flow Rate (No-Load):
Type 1: 60in³/min
Type 2: 100in³/min
- Typical current draw (up to 300 psi):
Type 1: 4–8A
Type 2: 5–11A
- Cylinder Capacity:
Type 1: 4.9–12.5in³
Type 2: 12.5–21in³

24V SEASTAR AUTOPILOT PUMP

- 24 Volts
- 1000psi MAX system pressure
- Flow Rate (No-Load):
Type 1: 60in³/min
Type 2: 100in³/min
- Typical current draw (up to 300 psi):
Type 1: 2–4A
Type 2: 3–6A
- Cylinder Capacity:
Type 1: 4.9–12.5in³
Type 2: 12.5–21in³

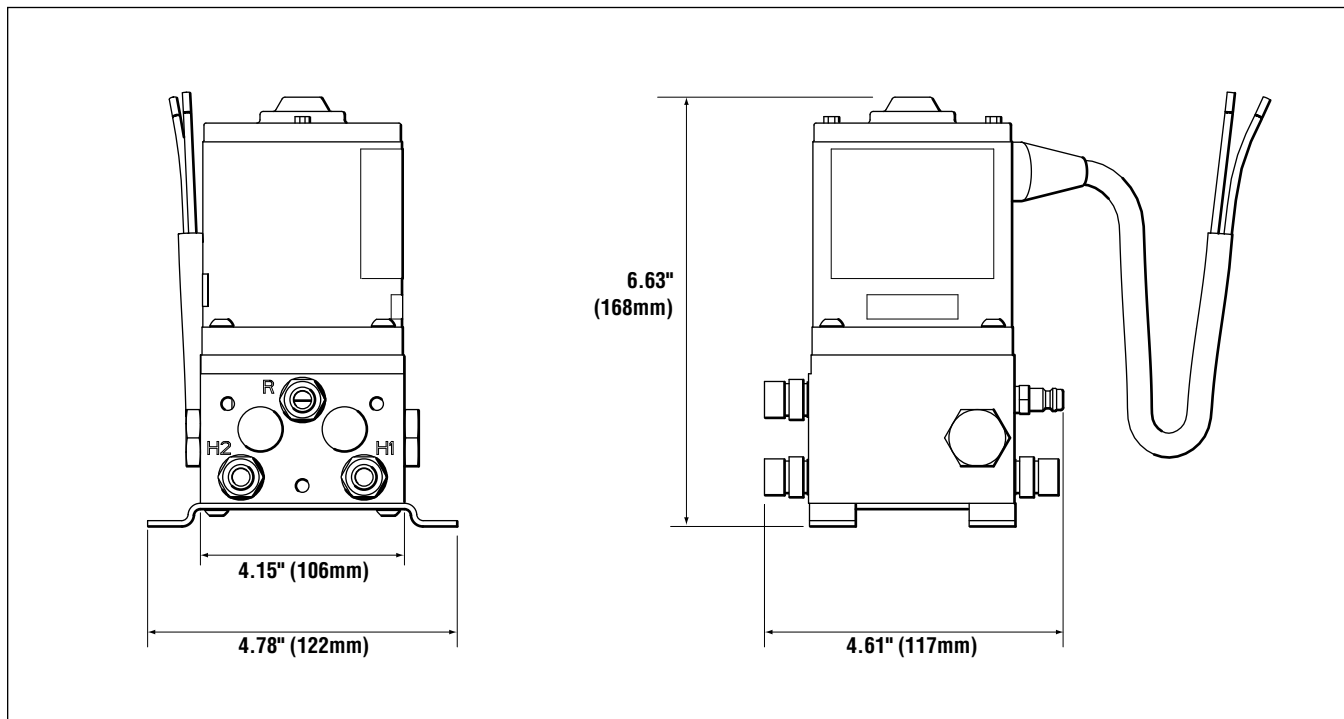

Figure 2.

NOTICE

To assist with the installation, a mounting template is provided on page 25.

SYSTEM INSTALLATION

Before Starting

Carefully study this manual and ALL other manuals provided with your SeaStar Steering system to familiarize yourself with all of the components and their intended, or required mounting locations. Ensure that there is adequate space available for installation of all components and easy access for service. It is good practice to mount all components before installing hoses. This allows port to port connection with less chance of an error. If you must run hoses first, a system of marking the various lines must be used. ALL hose ends must be closed with tape or similar material to prevent contamination. CONTAMINATION IS THE MOST COMMON CAUSE OF SYSTEM FAILURE.

Read ALL bold print text, notes, cautions and warnings. Reading them now will help prevent unexpected surprises during the installation.

These instructions have been made as complete as possible, and as brief as practical. If you have any questions, please contact your Distributor or SeaStar Solutions for assistance.

WARNING

Failure to follow these and ALL other installation instructions may cause loss of steering control leading to property damage, personal injury and/or death.

Tools

You will require the following tools to complete your installation.

- 1/2" and 3/4" open-ended wrench.
- Wire cutters, crimpers, soldering iron.
- Screwdriver for attaching mounting plate.
- All other tools noted with your helm pump and steering cylinder installation instructions.

Overview

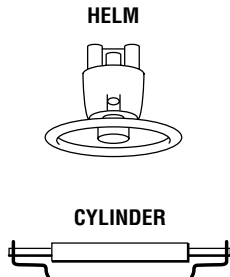

STEP 1 Mounting & Plumbing

- Install SeaStar helm pump(s) using installation instructions provided with your helm pump.
- Install steering cylinder(s) into boat using the installation manual instructions provided with your steering cylinder.
- Install Autopilot pump as per instructions on page 8.
- Install steering hoses as outlined on page 9 to page 11 of this manual.

NOTICE

Due to the different cylinders options available with SeaStar Steering, be sure that you choose the correct installation diagram noted in this book.

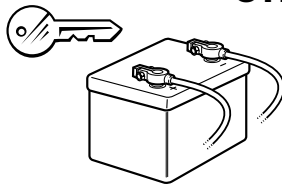

STEP 2 Electrical Connections

- Refer to page 12 for electrical connections.

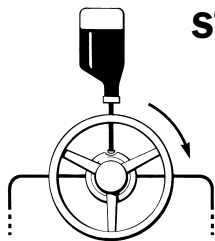

STEP 3 Filling and Purging

- Refer to page 13 for filling and purging of the steering system.

STEP 4 System Check

- Refer to page 20 of this manual.

Step 1 Mounting and Plumbing

1.1 Install Helm Pump(s)

- Install SeaStar Helm pump(s) using the instructions provided with your helm(s).

1.2 Install Steering Cylinder(s)

- Install SeaStar steering cylinder(s) using the instructions provided with your cylinder(s).

1.3 Autopilot Pump Mounting

NOTICE

To assist the installation, a mounting template is provided on page 25.

NOTICE

Autopilot pump must be mounted at a lower height than the highest helm pump in your system.

- Using the four (4) holes in the mounting bracket, mount the pump using #10 fasteners in your desired location. Prior to drilling, confirm that there is sufficient room to allow for hose connections and tightening of these hoses.
- Mount the autopilot pump as close to the cylinder as possible, in a cool and dry location, away from excessive heat sources such as engine manifolds. Avoid any areas that seem to collect water.
- Install the Autopilot pump in a vertical position (refer to figure 3). DO NOT mount the unit in a horizontal position.

NOTICE

The SeaStar Autopilot pump will make a noise similar to common Autopilot pumps; this should be taken into consideration when locating a mounting area for the units.

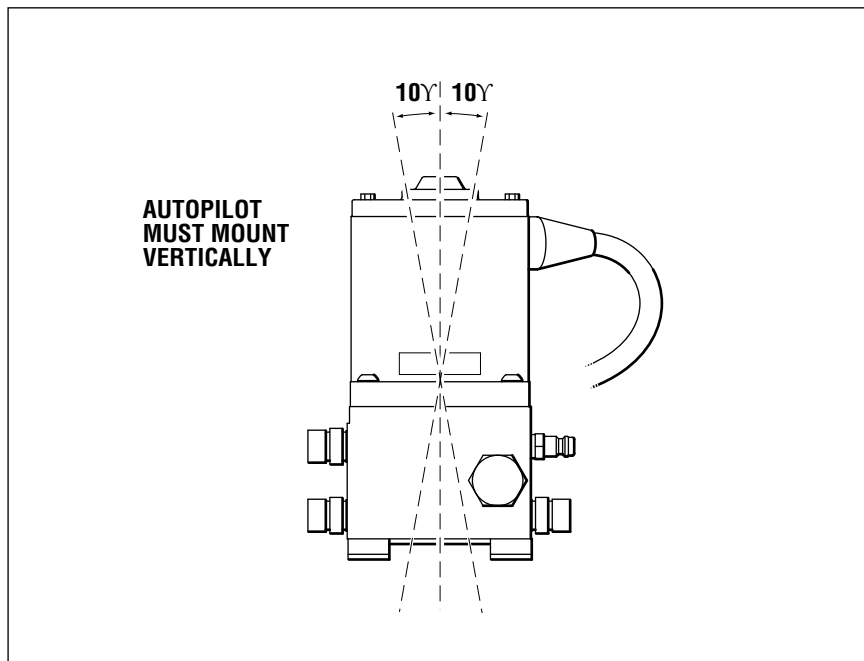

Figure 3.

⚠ WARNING

The SeaStar Autopilot pump may be hot to the touch. DO NOT mount the pump in an area where fabrics and/or any other flammable materials may come in contact with the units.

1.4 Plumbing the SeaStar Autopilot Pump

**Outboard Front Mount
Cylinders:**
HC5345-3, HC5347-3
HC5348-3, HC5358-3

I/O Cylinder:
HC5332-2

Hose connection is as follows.

- Helm to AP = S (helm) to H1 (AP), P (helm) to H2 (AP), lower R port (helm) to R (AP).
- AP to cylinder = C2 (AP) to starboard side (cylinder), C1 (AP) to port side (cylinder).

◀ PORT STARBOARD ▶

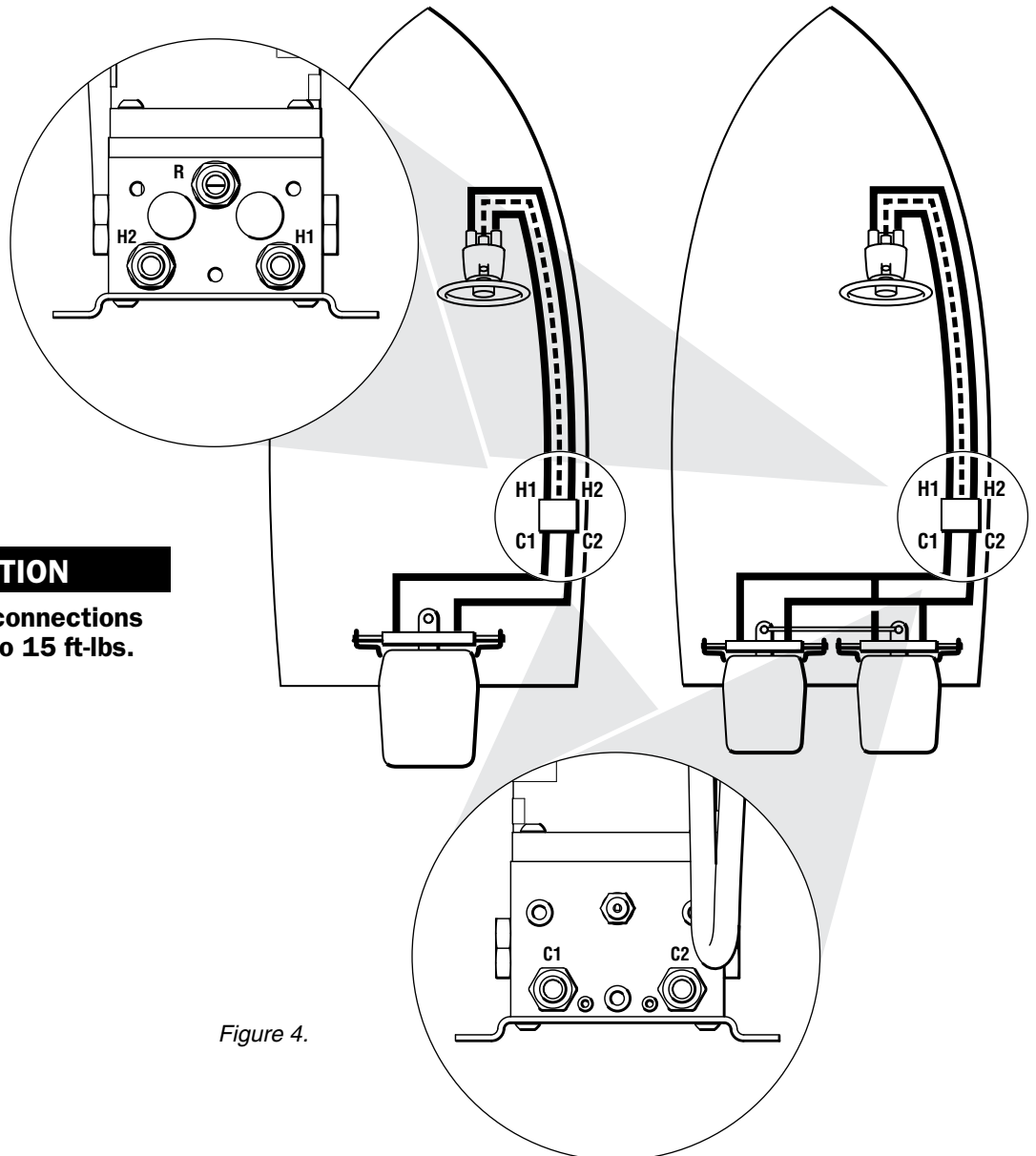

⚠ CAUTION

All SeaStar hose connections must be torqued to 15 ft-lbs.

Figure 4.

Side Mount Cylinder:
HC5370

Splashwell Cylinder:
HC5380

Hose connection is as follows.

- Helm to AP = S (helm) to H1 (AP), P (helm) to H2 (AP), lower R port (helm) to R (AP).
- AP to cylinder = C1 (AP) to starboard side (cylinder). C2 (AP) to port side (cylinder).

⚠ CAUTION

All SeaStar hose connections must be torqued to 15 ft-lbs.

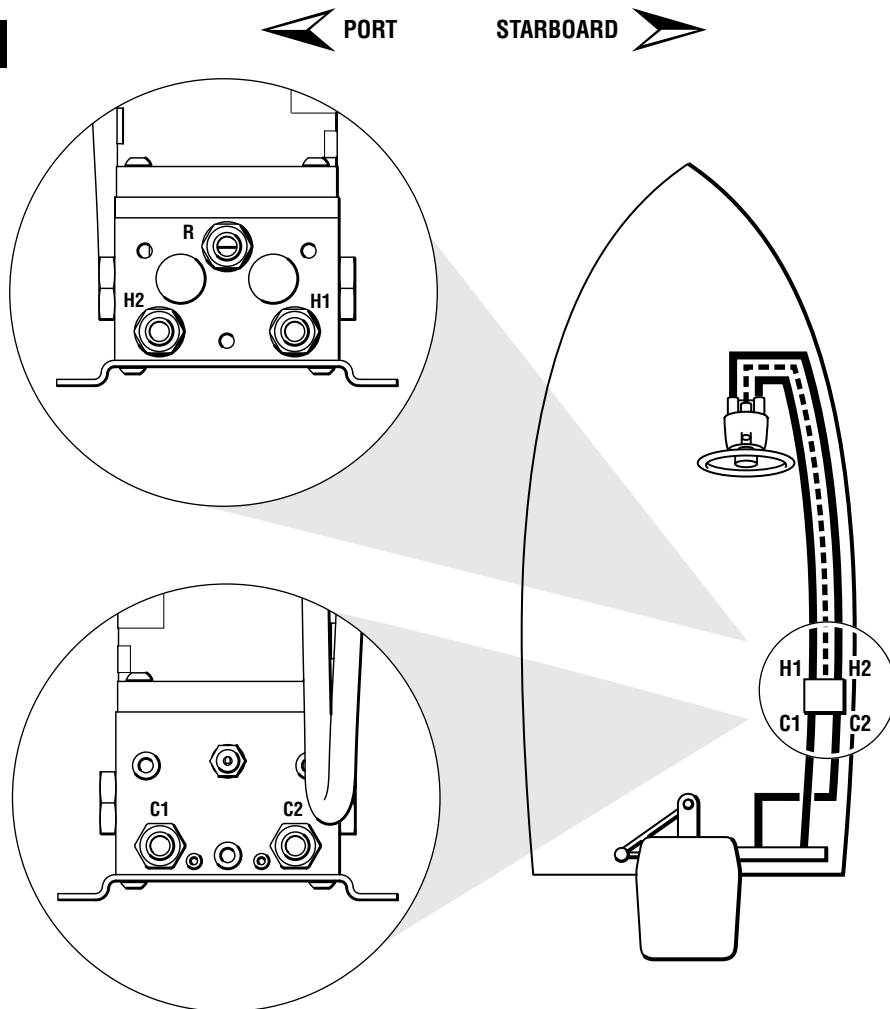

Figure 5.

All Inboard & Sterndrive
 Except: HC5332-2

Hose connection is as follows.

- Helm pump to AP = S (helm) to H1 (AP), P (helm) to H2 (AP), lower R port (helm) to R (AP).
- AP to cylinder = C1 (AP) to starboard side (cylinder), C2 (AP) to port side (cylinder).

⚠ CAUTION

All SeaStar hose connections must be torqued to 15 ft-lbs.

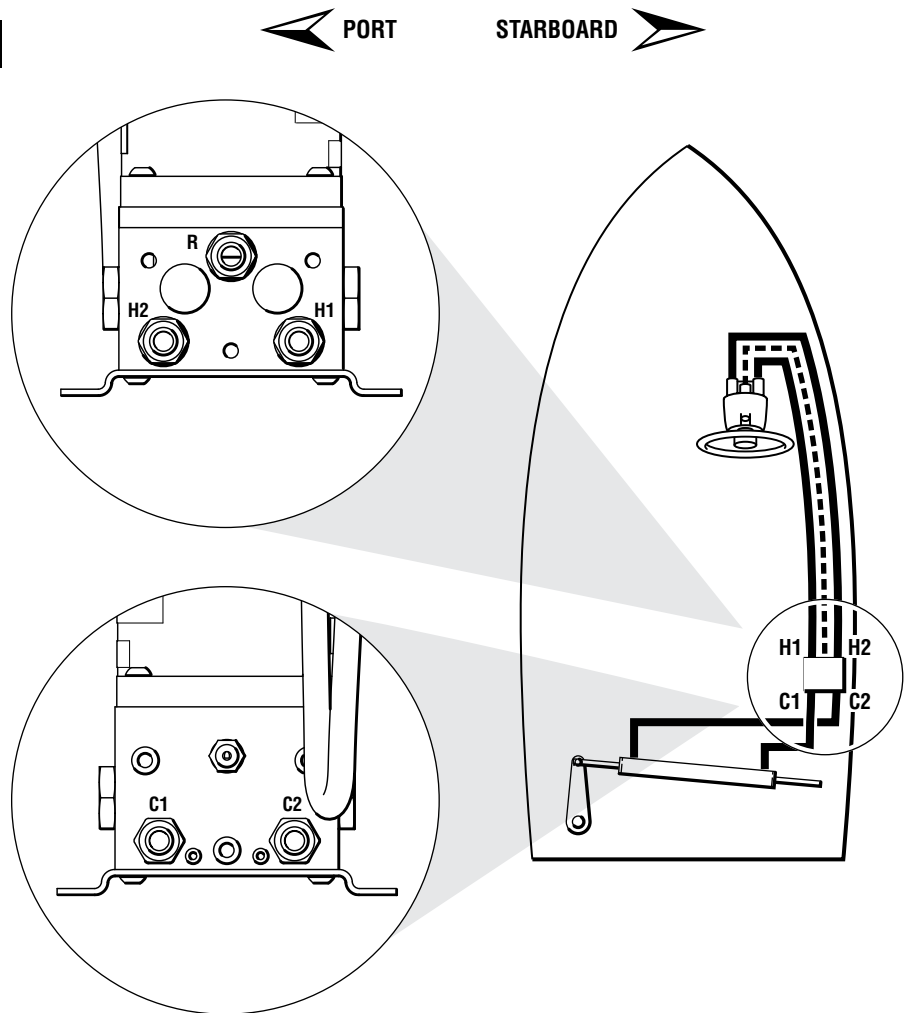

Figure 6.

Step 2 Autopilot Electrical Connections

Connect the Red (+) and Black (-) wires of the Autopilot pump to the controller as per the Autopilot manufacturers recommendations. The polarity may need to be reversed on some controllers in order to operate correctly.

When extending wire leads, marine best practices must be followed. Solder and shrink wrap are highly recommended. Appropriately sized and properly installed crimp connections with shrink wrap protection are also acceptable. A MIN of 12AWG wiring should be used for any extensions.

Lead wires should be kept as short as possible.

NOTICE

Refer to the Autopilot controller manufacturer for EMC wire guidelines, installation manuals and ALL notices, cautions and warnings.

⚠ WARNING

ONLY use approved electrical connectors or junction boxes with the correct power rating.

⚠ WARNING

If installing in an area where fumes from fuel are present, be sure to completely vent this area prior to making ANY electrical connections. Failure to do so may result in an explosion and/or fire causing property damage, personal injury and/or death.

Step 3 Filling & Purging the System

Read First

These instructions show how to fill and purge a SeaStar steering system with the SeaStar Autopilot pump installed. The same steps apply to ALL cylinders with the exception of which bleed fitting to open and close and the direction the cylinder rod moves. These variations are shown in inset diagrams at each step. For multiple steering stations, start with the lowest station while going through Steps 3.1.1 – 3.1.6, repeat at each higher station until complete. The use of a Power Purge kit (HA5445 or equivalent) is highly recommended and will improve the speed and quality of the purge procedure.

⚠ CAUTION

This procedure requires two people. One person may not be able to remove all the air from the system, which will result in spongy, unresponsive steering.

During the entire filling procedure, oil **MUST** be visible in the filler tube. **DO NOT** allow oil level to disappear into the helm pump, as this may introduce air into the system and increase your filling time.

Hydraulic Fluid

Due to recent upgrades in our steering system components, SeaStar Solutions recommends use of SeaStar Steering Fluid **ONLY** in our hydraulic steering systems. SeaStar Steering Systems have been engineered and validated using our proprietary SeaStar Hydraulic Steering Fluid. SeaStar Steering fluid is engineered with a special additive package that contains anti-foaming and anti-rusting agents, anti-oxidants, viscosity stabilizers, corrosion inhibitors, wear additives as well as water emulsification additives. It is highly recommended that SeaStar Steering Fluid be used to ensure optimum system performance and safety.

⚠ WARNING

Any non-approved fluid may cause serious damage to the steering system resulting in possible loss of steering, causing property damage, personal injury and/or death.

Use of any non-approved fluid may result in the following;

- higher steering effort, particularly at ambient or lower temperatures and/or over time due to oil degradation and breakdown
- increased steering slip and/or drift resulting in lost motion
- foaming or air entrapment causing a bumpy feel during steering
- high rates of moisture absorption causing internal component corrosion
- scratched steering cylinder bores and shafts due to contamination or elevated wear rates
- seal degradation – incompatibility with various proprietary seal compounds used in our products.

In an emergency, SeaStar EPS Fluid, any MD-3/4 rated ATF or MIL-PRF-5606H equivalent fluid that is filtered through a fine mesh screen can be used. The system **MUST** be thoroughly flushed as soon as possible with genuine SeaStar Steering Fluid after using an emergency fluid.

In an **EXTREME** emergency, any non-toxic, non-flammable fluid that is filtered through a fine mesh screen may provide temporary steering.

Use of non-standard fluids will require an immediate and complete system flush using approved fluids, by an approved steering technician.

⚠ WARNING

Never fill or mix brake fluids, triglycerides or polyalkylene glycols within a hydraulic steering system.

NOTICE

SeaStar Hydraulic Steering Fluid can be used in Hynautic, BayStar and BayStar Plus steering systems.

NOTICE

Help protect your boating environment by ensuring that all used oil is disposed of properly.

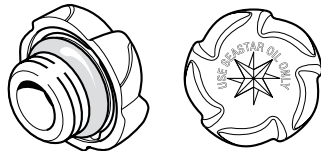
Fill Plugs for SeaStar Helms**VENT PLUG - Part No. HP6126****SUPPLIED WITH SEASTAR HELM PUMP**

- MUST BE USED WITH HELM PUMP ON ALL SINGLE STEERING STATION SYSTEMS.
- MUST BE USED ON UPPERMOST HELM PUMP ON MULTI STEERING STATION SYSTEMS.

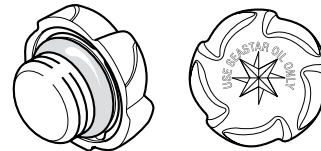
NON-VENT PLUG - Part No. HP6000

- MUST BE USED ON ALL HELM PUMPS OTHER THAN UPPERMOST HELM PUMP ON MULTI STEERING STATION SYSTEMS.

- THIS NON-VENT PLUG IS SUPPLIED WITH ADDITIONAL STATION FITTING KIT NO. HF5501 AND HF5502.

Figure 7.

Step 3.1 Fill & Purge Manually

NOTICE

If using the SeaStar Power Purge JR/SR please refer to page 18.

The following procedure applies to a single helm and single cylinder installation.

Other configurations will require this procedure plus the additional steps outlined on page 19.

3.1.1

- Attach helm filler kit (HA5438) and fluid bottle to the helm. Refer to figure 8.

NOTICE

Filling the helm full of fluid prior to connecting the filler tube and oil bottle will decrease purge time.

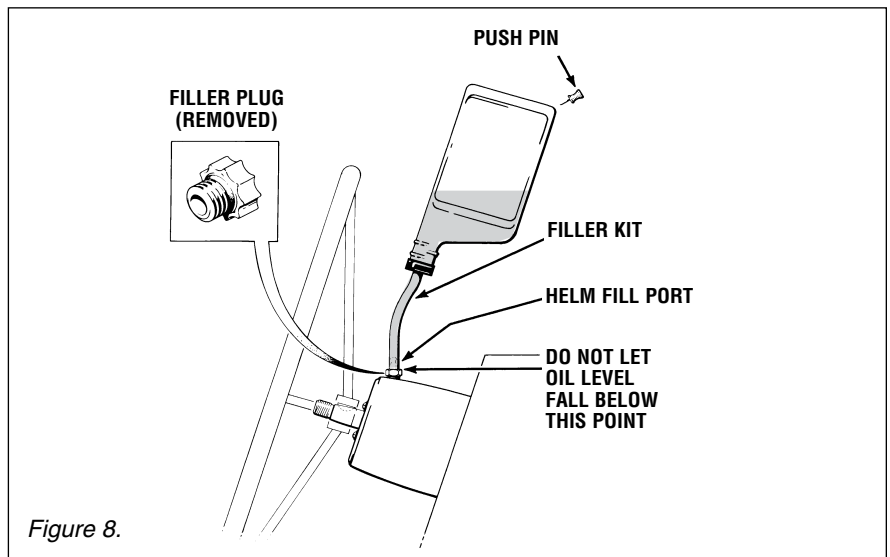

3.1.2

- Turn the steering wheel clockwise until the cylinder rod is fully extended as shown below.
- Open bleed fitting as per your installation.

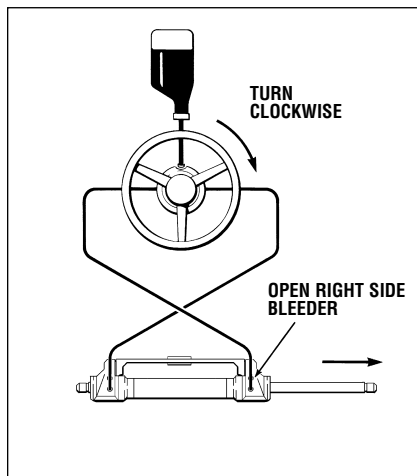

Outboard Front Mount & HC5332-2 Cylinder

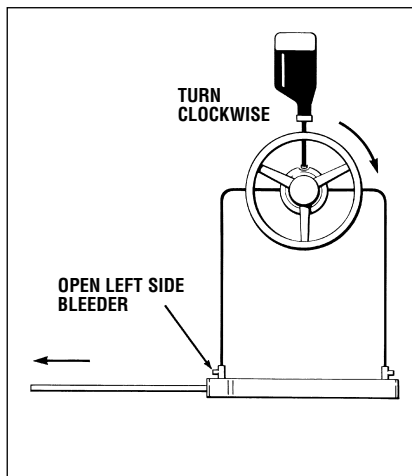

Side Mount / Splashwell Mount Cylinder

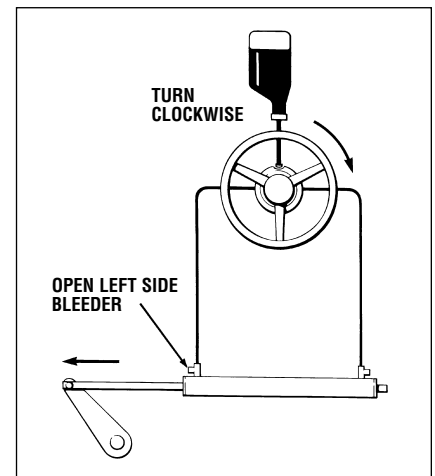

All Balanced Cylinder. Inboard & Sterndrive Cylinders

3.1.3

- Holding the cylinder body (Outboard Front Mount cylinder) or rod (Side Mount cylinder) to prevent the body/rod from moving, turn the steering wheel counter-clockwise until a steady stream of air free oil comes out of the bleeder. (Drain approx. 1/2 bottle of oil or as required).

Do not use anything other than your hands to restrain the cylinder body/rod.

- **Run SeaStar Autopilot pump continuously in the same direction you have been turning for a minimum of 2 minutes.**
- While continuing to turn the wheel close the bleed fitting for your installation and let go of the cylinder body/rod.

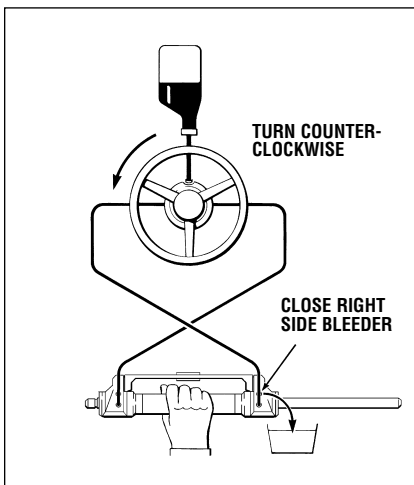

Outboard Front Mount & HC5332-2 Cylinder

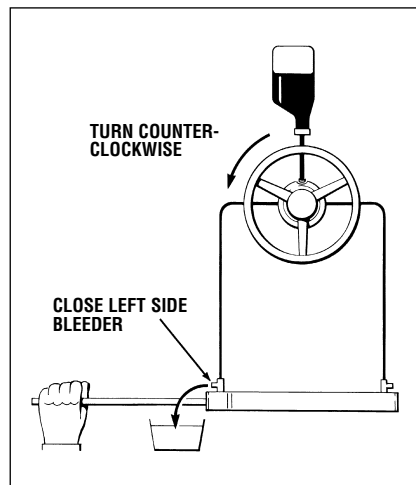

Side Mount / Splashwell Mount Cylinder

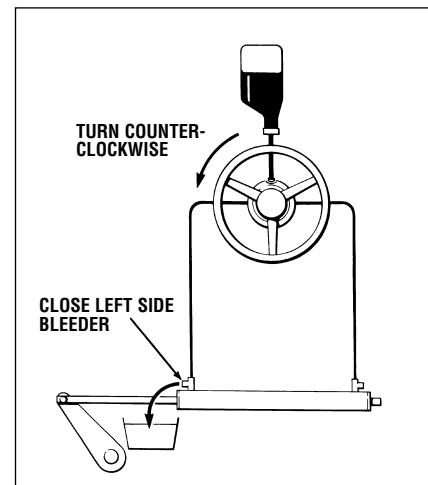

All Balanced Cylinder, Inboard & Sterndrive Cylinders

3.1.4

- Continue turning the steering wheel counter-clockwise until the cylinder rod is fully extended as shown below. Steering wheel will come to a stop.
- Open bleed fitting as per your installation.

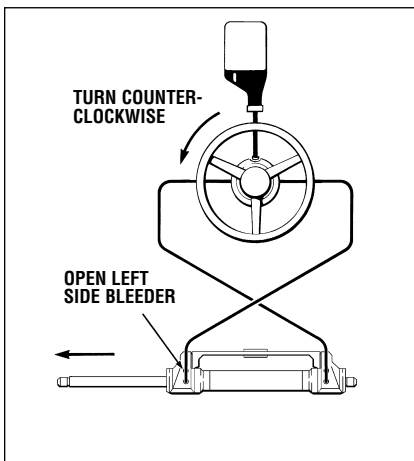

Outboard Front Mount & HC5332-2 Cylinder

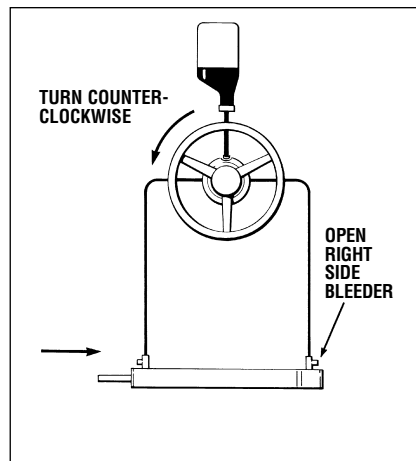

Side Mount / Splashwell Mount Cylinder

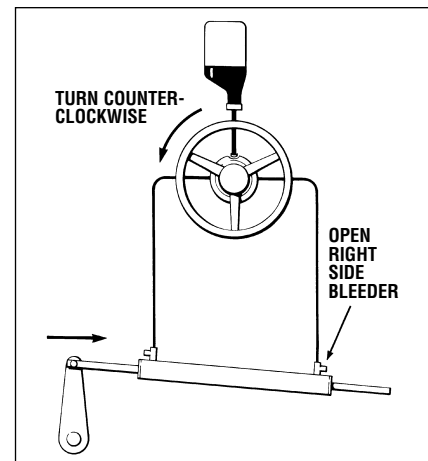

All Balanced Cylinder, Inboard & Sterndrive Cylinders

3.1.5

- Holding the cylinder body (Outboard Front Mount cylinder) or rod (Side Mount cylinder) to prevent the body/rod from moving, turn the steering wheel clockwise until a steady stream of air free oil comes out of the bleeder.
- **Run SeaStar Autopilot pump continuously in the same direction you have been turning for a minimum of 2 minutes.**
- While continuing to turn the wheel close the bleed fitting for your application and let go of the cylinder body/rod.
- Torque all cylinder bleed fittings to 180 in-lbs.

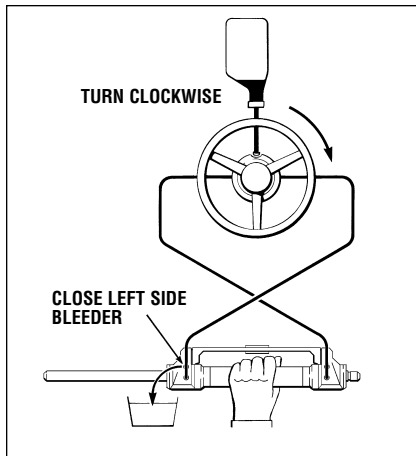

Outboard Front Mount & HC5332-2 Cylinder

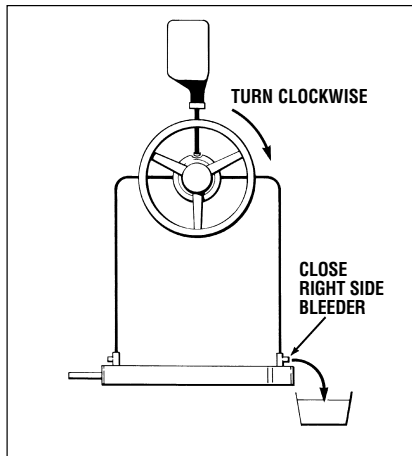

Side Mount / Splashwell Mount Cylinder

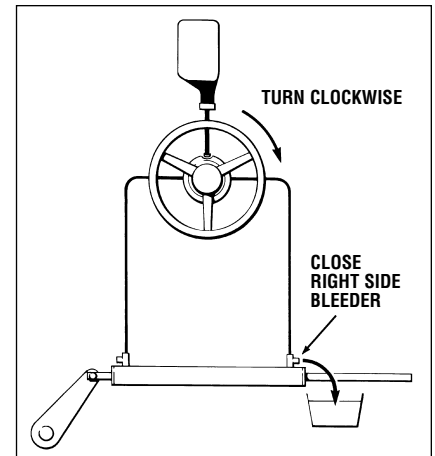

All Balanced Cylinder. Inboard & Stern Drive Cylinders

3.1.6

- Open Autopilot pump reservoir bleed fitting. Refer to figure 9.
- Wait approximately 30 seconds while reservoir purges. Fluid may or may not exit bleeder at this time depending on individual configuration.
- Close reservoir bleed fitting and torque to 180 in-lbs.

CAUTION

Prior to operating system, perform Oil Level System Check, refer to page 20.

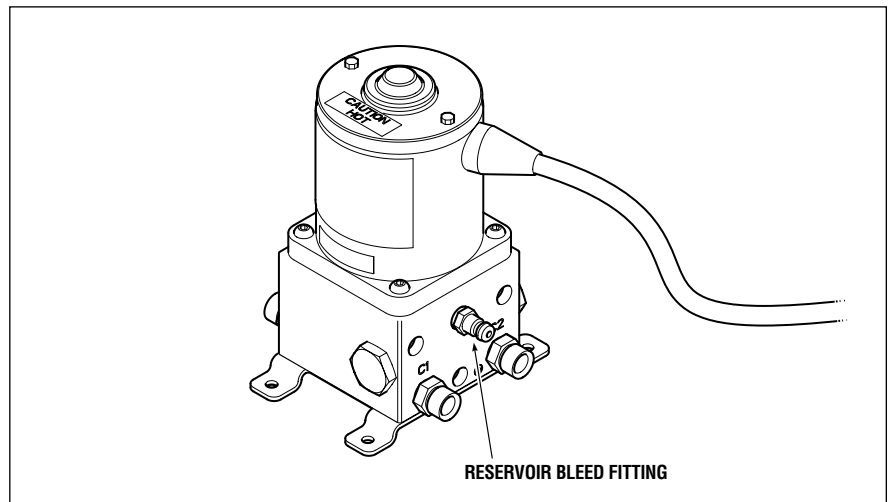

Figure 9.

Step 3.2 Fill & Purge using Power Purge

NOTICE

BEFORE bleeding the main steering system (helm, hoses and cylinders), the RETURN line will need to be purged.

3.2.1

- Install the helm adapter into the helm pump and attach the helm hose from the power purge unit.
 - Connect one of the fluid return hoses (cylinder lines) from the Power Purge unit to the reservoir bleed fitting on the SeaStar Autopilot pump (see figure 9 on page 17 for bleed fitting location).
 - Open reservoir bleed fitting 1 turn.
-

⚠ CAUTION

Refer to your Power Purge installation manual for important Warnings and Notices while using the Power Purge Units.

- Turn ON the Power Purge unit and continue to run until NO air is visible leaving the SeaStar Autopilot pump.
 - Turn OFF Power Purge unit.
 - Close the reservoir bleed fitting and torque to 180 in-lbs.
-

3.2.2

- Remove the hose from the reservoir bleed fitting and connect to the bleeder fittings on the steering cylinder. Be sure that the quick connect is locked onto the fitting.
 - Open ALL cylinder bleed fittings 1-1/2 turn.
 - Turn Power Purge unit ON.
 - Oil should flow into and out of the helm pump. Wait twenty seconds for the helm to fill with oil.
 - Quickly turn the steering wheel clockwise until the cylinder rod is fully extended (you may have to manually push the cylinder rod). SLOWLY continue to turn the wheel to hold the cylinder in this position for approximately 30 seconds. Ensure there are NO air bubbles escaping through the cylinder hoses.
 - Quickly turn the steering wheel counter-clockwise until the cylinder rod is fully extended (you may have to manually push the cylinder rod). SLOWLY continue to turn the wheel to hold the cylinder in this position for approximately 30 seconds. Ensure there are NO air bubbles escaping through the cylinder hoses.
 - Turn OFF Power Purge unit.
 - Remove hoses and replace helm vent cap.
 - Tighten ALL bleed fittings on the steering cylinder(s) and torque to 180 in-lbs.
-

3.2.3

Continue on with Oil Level and System Check on page 20.

Step 3.3 Additional Purge Instructions

3.3.1

Twin Station Single Cylinder

Perform Steps 3.1.1 – 3.1.6 at station no. 1. Then repeat Steps 3.1.2 – 3.1.5 at station no. 2.

Note: Refer to Oil Level & System Check on page 20.

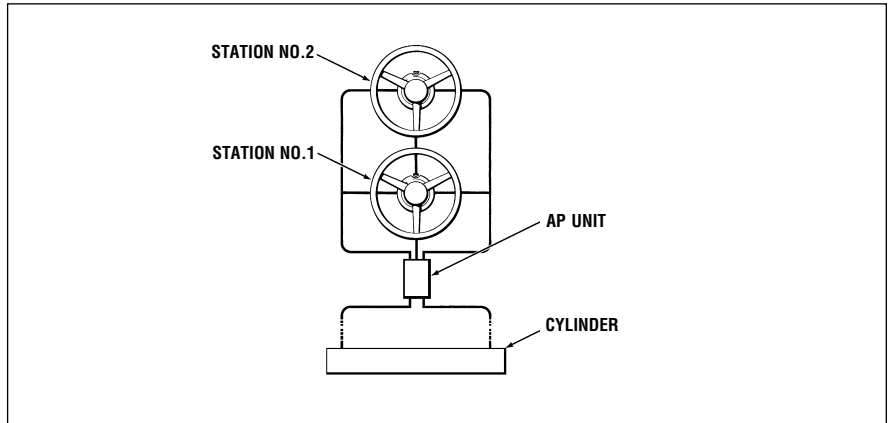

3.3.2

Single Station Twin Cylinder

When performing Steps 3.1.1 – 3.1.6, perform instructions in each step first on cylinder no. 1 and then on cylinder no. 2, before proceeding to the next step. ie: Perform instructions referring to right side of cylinder first on cylinder no. 1 and then on cylinder no. 2.

Note: Refer to Oil Level & System Check on page 20.

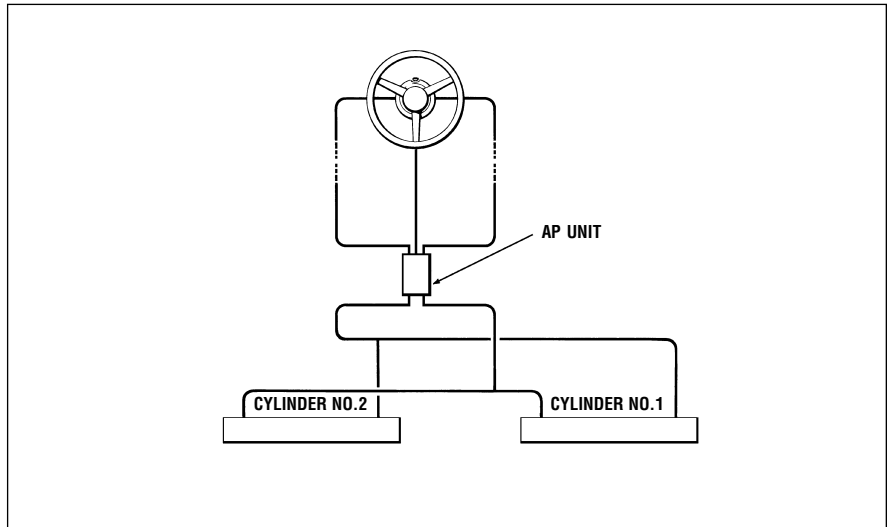

3.3.3

Twin Station Twin Cylinder

Follow same procedure as instructed for single station-twin cylinders, beginning at station no. 1, and repeat entire procedure at station no. 2.

Note: Refer to Oil Level & System Check on page 20.

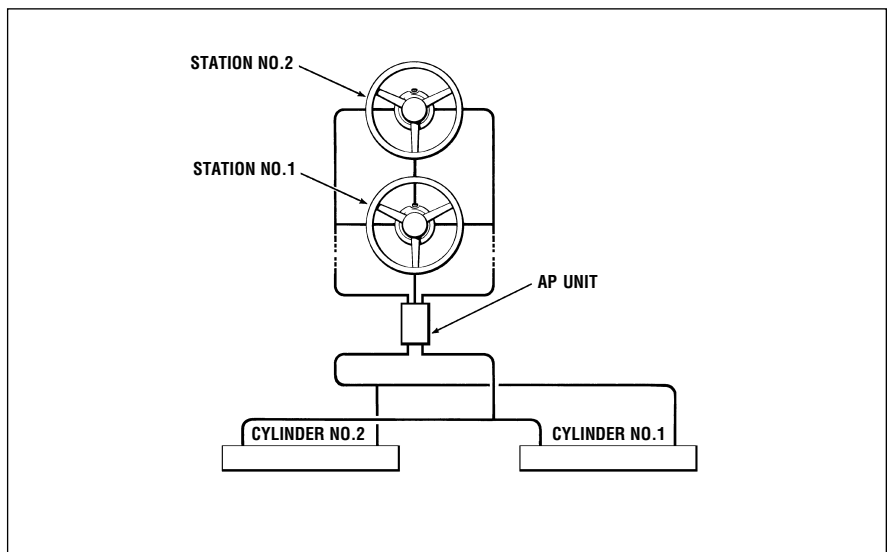

Step 4 System Check

At this time the steering system must be checked for proper hose and fitting connections, possible leaks, and air removal. Please complete the following steps with the Autopilot pump OFF.

- Turn steering wheel to hard over, then force the wheel another one quarter to one half turn past the stop point. Check the following areas for evidence of a leak.
 - Inspect helm fittings
 - Inspect Power Assist/Autopilot interface (if installed) and Autopilot pump fittings
 - Inspect cylinder and cylinder bleed fittings
 - Inspect hoses
- Repeat above steps to the other steering direction.
- Any sign of a leak **MUST** be repaired prior to operating the boat.
- While turning steering wheel observe fluid level in the helm pump. If fluid level drops and rises significantly as the wheel is being turned there is still air in the system. Complete bleeding instructions again until no obvious fluid level change is noticed.

Consult with autopilot controller manual for the remainder of the autopilot check list.

NOTICE

Helms mounted with the wheel shaft completely horizontal must be filled to the bottom of the filler hole at all times. Do NOT allow the fluid level to drop more than one-quarter inch below the filler hole.

NOTICE

*Helms mounted on a 20 degree angle or with the wheel shaft vertical **MUST** have the fluid level within 1/2" of the filler hole, refer to the diagram below.*

⚠ WARNING

If a leak is noticed, it **MUST be corrected prior to using the boat. Failure to do so may lead to loss of steering causing property damage, personal injury or death.**

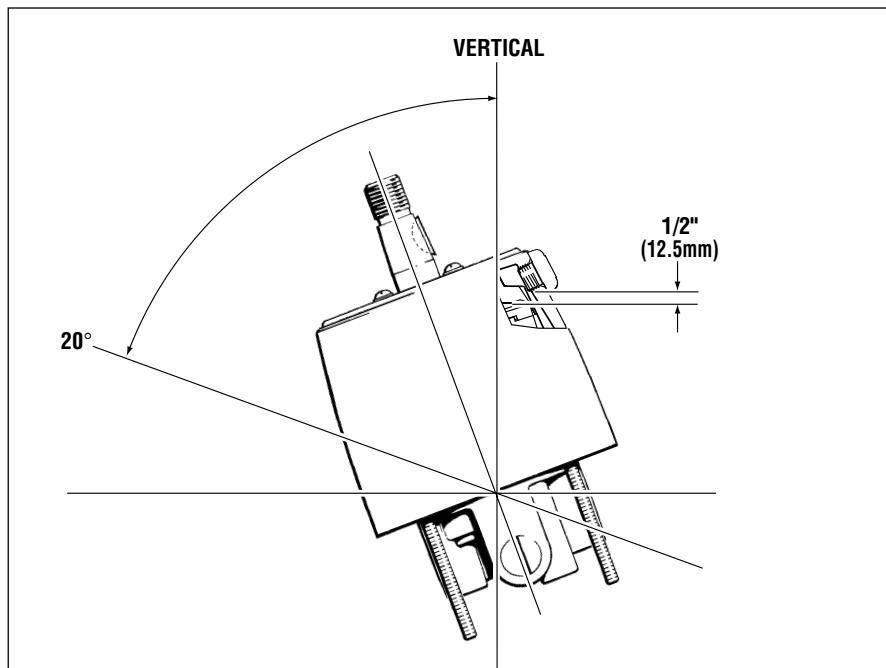

Figure 10.

MAINTENANCE

NOTICE

Check the oil level of highest helm in your system routinely. Any loss of fluid indicates a leak somewhere in the system which must be repaired immediately before operating the vessel.

Hoses should also be routinely inspected. Replace any hose(s) showing signs of wear and remove the cause or reroute the hose(s).

Check all fittings and seal locations for leaks/damage and services as necessary.

WARNING

Failure to comply with maintenance checks may result in loss of steering, causing property damage and/or personal injury.

Maintenance requirements will vary depending on usage and climate. Bi-annual inspection by a qualified marine mechanic is required.

TROUBLESHOOTING GUIDE

NOTICE

These troubleshooting notes have been gathered from several cases throughout the years. Whenever a solution calls for removal of parts, disassembly of parts etc. The work must ONLY be performed by a 'Qualified Marine Technician'.

FAULT	CAUSE	SOLUTION
1. Steering response is slow and feels bumpy	Leak/Air in system	Repeat system check inspecting system for leaks. Rebleed system.
2. Steering is very hard (stiff)	Partially kinked or collapsed line	Check all lines for signs of a collapsed or kinked line
3. Autopilot motor is really hot to the touch	Partially kinked or collapsed line Controller settings are incorrect	See step 2 Refer to autopilot controller manual
4. Autopilot pump steering in wrong direction	Motor polarity reversed	Reverse motor leads at Autopilot controller
5. Autopilot pump will not turn on	Blown Fuse Electrical connections are wrong	Check for blown fuses and bad connections in Autopilot wiring. Refer to page 12.
6. Autopilot pump draws too much current	Partially kinked or collapsed line. Controller not properly sized	See step 2 Review pump Specifications
7. Autopilot pump hunts/overshoots	Refer to autopilot controller manual	Refer to autopilot controller manual
8. Helm locks up in both directions	Hoses installed in the wrong ports. Kinked or collapsed line	Review the plumbing diagrams for your system noted on page 9 through page 11, confirm that your hoses are hooked up correctly. Check ALL lines for sign of a collapsed or kinked line.
9. Helm only turns in one direction and free wheels in the other	Port or Starboard line is connected to the reservoir R port on the Autopilot Pump.	Review the plumbing diagrams for your system noted on page 9 through page 11, confirm that your hoses are hooked up correctly.

Statement of Limited Warranty

We warrant to the original retail purchaser that **Marine Canada Acquisition Inc. DBA SEASTAR SOLUTIONS** (herein forward referred to as **SeaStar Solutions**) products have been manufactured free from defects in materials and workmanship. This warranty is effective for two years from date of purchase, excepting that where **SeaStar Solutions** products are used commercially or in any rental or income producing activity, then this warranty is limited to one year from the date of purchase.

We will provide replacement product without charge, for any **SeaStar Solutions** product meeting this warranty, which is returned (freight prepaid) within the warranty period to the dealer from whom such product were purchased, or to us at the appropriate address. In such a case **SeaStar Solutions** products found to be defective and covered by this warranty, will be replaced at **SeaStar Solutions** option, and returned to the customer.

The above quoted statement is an extract from the complete **SeaStar Solutions** products warranty statement. A complete warranty policy is available in our **SeaStar Solutions** products catalogue.

Return Goods Procedure

Prior to returning product to **SeaStar Solutions** under warranty, please obtain a *Return Goods Authorization number* (claim number).

Be sure to label the goods with:

- a) the name and address of the sender, and
- b) the return goods authorization number (claim number)

Please address the returned goods as follows:

From U.S.A.

RGA # ?
SeaStar Solutions
c/o UPS-SCS
19308 70th Ave S.
Kent, WA 98032

From Canada

RGA # ?
SeaStar Solutions
3831 No.6 Road
Richmond, B.C.
Canada V6V 1P6

Technical Support

Phone: 604-248-3858

email: seastar@seastarsolutions.com

Hours: Monday - Friday 05:00 – 15:30 PST

Web: www.seastarsolutions.com

This page left intentionally blank.

MOUNTING TEMPLATE

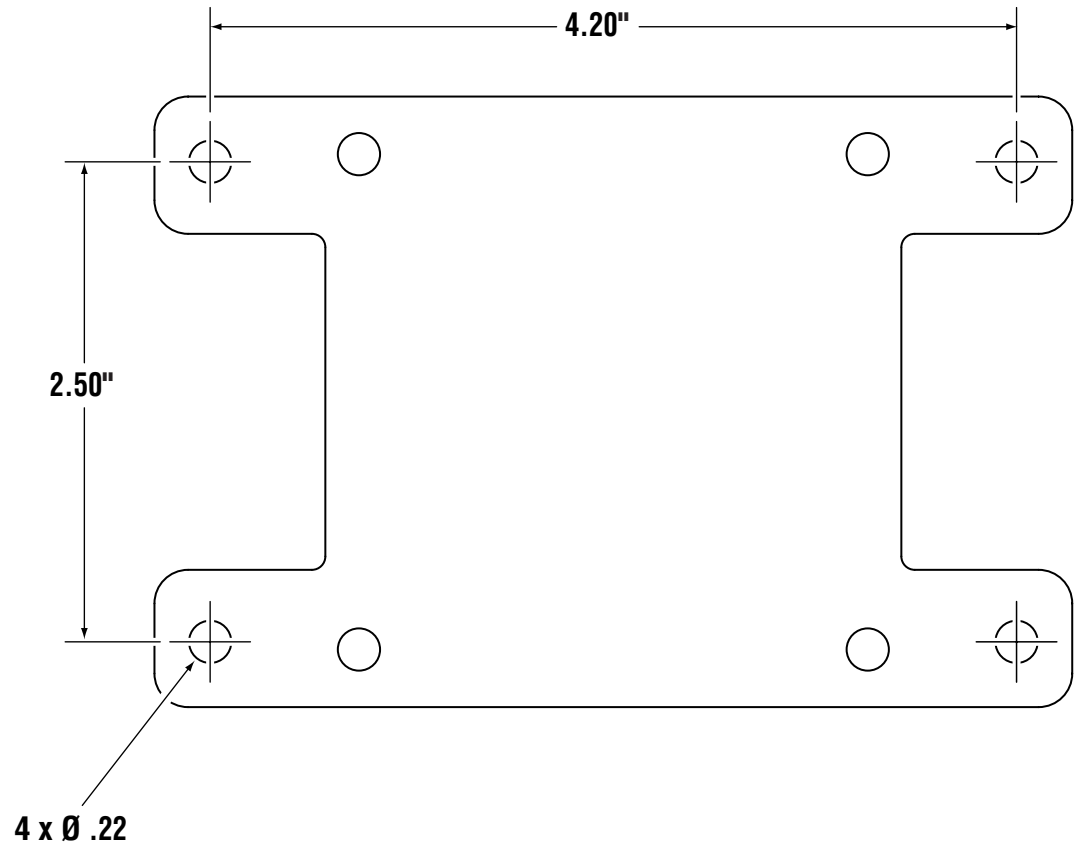

NOTICE

If this mounting template is photocopied, ALL measurements must be checked using a measuring device prior to use.



This page left intentionally blank.



**SEASTAR
SOLUTIONS®**

SEASTAR SOLUTIONS
3831 NO.6 ROAD
RICHMOND, B.C.
CANADA V6V 1P6

FAX 604-270-7172

www.seastarsolutions.com

ISO 10592



FORM NO. 798320 REV. D

© 2007 MARINE CANADA ACQUISITION INC.
DBA SEASTAR SOLUTIONS

PRINTED IN CANADA

100-03/16