



SEASTAR™
BAYSTAR™

-3 HELM FITTING INSTALLATION TORQUE

We have recently been made aware that our new dash 3 SeaStar and BayStar steering helms with positionable ORB fittings have an incorrect installation torque stated in the installation instructions. Due to fitting and casting variability, there is a potential to damage threads on the rear cover using the old torque specification. Please install fittings as per the updated torque specification of 18 ft-lbs shown by the installation procedure below. All of our current installation manuals have been updated to reflect this change.

-3 Helm Pump Fitting Installation

⚠ WARNING

Failure to properly tighten the lock-nut (item 1) may lead to loss of steering control. Loss of steering control may result in unpredictable boat behavior, collision with an obstacle and/or ejection from vessel, leading to property damage, personal injury and/or death.

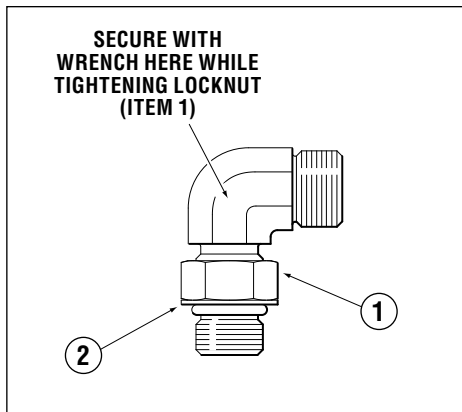

Figure A.

⚠ WARNING

SeaStar Solutions recommends that the hose and hose fittings are checked on a regular basis to ensure the safe operation of the steering system.

NOTE: for straight ORB fittings (inc. HF6009 & HF6012 fitting kits) simply torque fitting to 18 ft-lbs. Fitting re-orientation not required.

1. Back off lock nut (item 1), counter-clockwise, until it stops.
NOTE: O-ring must be fully on sealing surface and cannot contact any threads. Do not use Teflon tape or any liquid pipe sealant with ORB fittings.
2. Thread fitting into helm port until fitting washer (item 2) contacts the face of the helm port. Tighten hand tight. **DO NOT USE A WRENCH.**
3. Re-position fitting to desired orientation by turning it counter-clockwise to a MAXIMUM of 1 full turn.
4. While holding the fitting body securely with a wrench, torque the lock nut (item 1) to **18 ft-lbs.**
5. While holding the fitting body securely with a wrench, torque the hose end nut to 15 ft-lbs.
6. Purge system per applicable instruction manual.

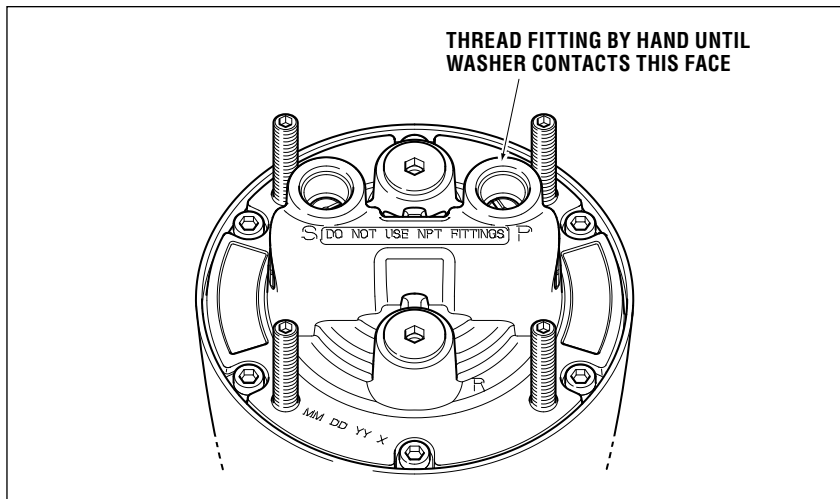

Figure B.

Please note that the installation of ORB fittings for steering cylinders remains as stated in the Installation and Owner's Manual at 40–43 ft-lbs.

Should you require any further assistance, please contact SeaStar Technical Support at: 1-604-248-3858.