



**INSTALLER: THESE INSTRUCTIONS CONTAIN IMPORTANT SAFETY INFORMATION AND MUST BE FORWARDED TO THE BOAT OWNER.**

**THIS KIT CONTAINS PARTS REQUIRED TO CONNECT OUTBOARD MOTORS TO REMOTE STEERING SYSTEMS (MANUFACTURED BY SEASTAR SOLUTIONS) WHEN USED IN MOTOR MOUNTED APPLICATIONS.**

## NOTICE

Application is restricted – use only on 1977 to 1984 Engines of the following horsepower ratings only:

<u>Johnson/Evinrude:</u>		<u>Mercury</u>	
		1977	1984
55 HP	140 HP		
70 HP (Long Shaft)	150 HP	85	80
75 HP (Long Shaft)	175 HP	115	90
85 HP	200 HP	150	115
100 HP	235HP		140

### CAUTION

**READ THESE INSTRUCTIONS THOROUGHLY BEFORE PROCEEDING WITH INSTALLATION. MOTOR PIVOTS MUST BE ADJUSTED AND LUBRICATED IN ACCORDANCE WITH THE MOTOR MANUFACTURER'S INSTRUCTIONS. IN ORDER TO AVOID EXCESS STEERING LOADS AND TO OPTIMIZE STEERING CHARACTERISTICS, MOTOR TRIM TABS MUST BE ADJUSTED ACCORDING TO THE MOTOR MANUFACTURER'S INSTRUCTIONS FOR THE SPECIFIC MOTOR AND BOAT COMBINATION. FAILURE TO DO SO CAN AFFECT BOAT PERFORMANCE AND SAFETY OF OPERATION. CHECK CONTENTS OF THE KIT AGAINST PARTS LIST ON THE INSTRUCTION SHEET. PARTS SUPPLIED MUST BE USED PER INSTRUCTIONS. SEASTAR SOLUTIONS CANNOT ACCEPT RESPONSIBILITY FOR THE INTEGRITY OF INSTALLATIONS IN WHICH SUBSTITUTE PARTS ARE USED.**

**THIS LINK ARM IS NOT DESIGNED FOR USE WITH MERCURY BLACK MAX ENGINES.**

### INSTRUCTIONS FOR INSTALLATION

1. Remove the two plastic protective caps from ends of motor tilt tube.
2. Apply a waterproof marine grease and slide Steering Cable output ram through tilt tube (See Figure 1). Thread Coupler Nut fully onto tilt tube. Tighten securely (approximately 15 foot/pounds.) NOTE: The Coupler Nut has a locking feature in the threads. Make sure nut is drawn up fully and the locking feature is engaged.
3. Slide Boot and Wiper assembly (item 1) over output ram and press firmly onto tilt tube until fully seated.
4. Insert short leg of Link Arm Assembly (item 2) into hole in end of output ram. Add Flat Washer (item 3) and thread on the Thick Lock Nut (item 4).

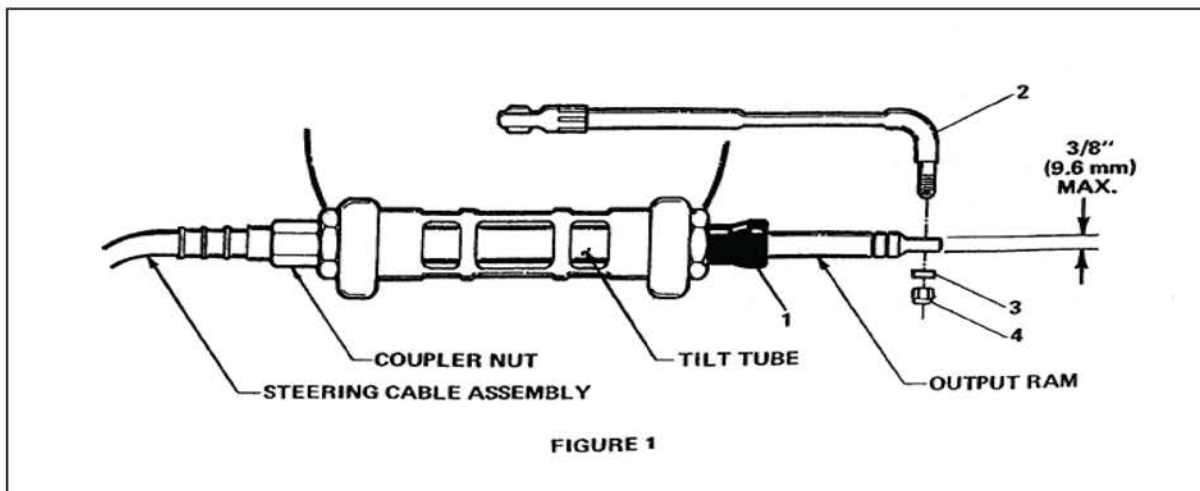

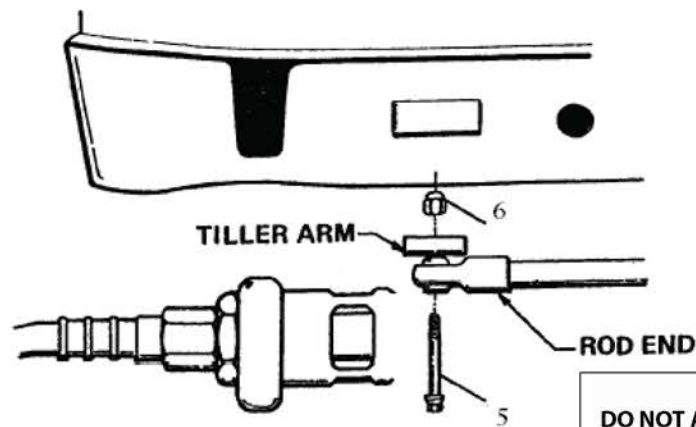

**FIGURE 2**

**CAUTION:**  
DO NOT ATTEMPT TO ADJUST LENGTH OF  
LINK ARM BY UNTHREADING ROD END.

Tighten Nut snugly, then back off slightly (approximately ½ turn) until Washer is free to rotate.

5. Use wheel to center steering system, then rotate motor to bring tiller arm over hole in Rod End (See Figure2). Position Rod End under tiller arm. Insert Bolt (item 5) upward through Rod End and thread fully into hole in tiller arm as shown. Tighten securely. Thread on Thin Lock Nut (item 6) and tighten.

PARTS LIST		
Item	Description	Qty
1	Boot and Wiper Assembly	1
2	Link Arm Assembly	1
3	Flat Washer 3/8"	1
4	Thick Lock Nut 3/8"	1
5	Bolt 3/8-24x1-5/8"	1
6	Thin Lock Nut 3/8"	1

### MAINTENANCE NOTES

1. After a few hours of operation following installation of this kit periodically thereafter, re-torque all fasteners and check the steering system for security and integrity.

**CAUTION:**  
LOOSENING OR SEPARATION OF ONE OR MORE FASTENERS MAY CAUSE FAILURE OF THE STEERING SYSTEM, RESULTING IN PROPERTY DAMAGE AND PERSONAL INJURY.

2. Flush telescopic area (cable output end) with fresh water after operation in salt water. Periodically lubricate the telescopic output ram with waterproof grease. On motors where the support tube does not protrude sufficiently to allow for installation of the boot and wiper, regular and frequent checks must be made to insure that corrosion build-up within the tube does not interfere with the operation of the steering system. When such occurs, detach link arm from the telescopic then remove telescopic from the support tube. Clean the bore of the support tube thoroughly, and lubricate with waterproof grease. Reinstall telescopic and link arm in accordance with the foregoing instructions. When storing the boats for extended periods, lubricate the output ram when fully extended, then retract completely for storage.

3. Inspect for corrosion. All metal parts meet or exceed applicable specifications for corrosion resistance; however, with extended operation under extreme conditions, corrosion may occur and affected parts should be replaced.

### CAUTION:

OVERTORQUING MAY STRIP THREADS FROM BOLT OR NUT.

### FINAL MECHANICAL CHECK OUT

1. Move the motor through the normal operating positions (side to side and through tilt range) to ensure that no interference or restriction of movement exists.
2. Check Coupler Nut attaching Steering Cable to tilt tube and all attaching hardware for security. Re-torque if necessary.
3. Using the steering wheel, check for proper action of steering controls. Rotating the wheel to turn right (Clockwise) should cause the boat to turn right (starboard). The installation is now complete.

**NOTE:** The boat should be operated with caution until the steering system has been thoroughly checked under normal operating conditions, to ensure that the installation is correct and functioning properly.