

MEMBER
ABYC
Setting Standards for Safer Boating

INSTALLATION INSTRUCTIONS AND OWNERS MANUAL

Part # IS-SH91545, Rev 2, 07/2013

www.seastarsolutions.com



SH91524 DUAL

SH91523 SINGLE

safe-t

Mechanical Steering for Inboard,
Outboard, and Sterndrive
Powered Vessels

SAFE-T® QC ROTARY STEERING HELMS
SH91523 SINGLE AND SH91524 DUAL

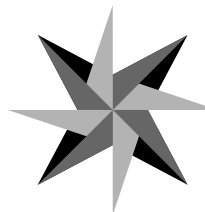

SEASTAR
SOLUTIONS®

big-t
jbs
nfb
rack
safe-t
xtreme

MANUFACTURED BY
MARINE ACQUISITION INCORPORATED
DBA SEASTAR SOLUTIONS
U.S.A.

*Before you do it your way,
please try it our way.*

SAFE-T®

TILT HELM

Q.C. Single SH91523, Dual SH91524
Std. Single SH91521, Dual SH91522

NOTICE

Installer: these instructions contain important safety information and must be forwarded to the boat owner.

These instructions describe how to install Safe-T® HELMS for a PERFORMANCE TILT steering system. Instructions for installing steering cables are also included.

In addition to this kit the following components are required for a complete PERFORMANCE TILT system:

- SH91800 SPORT or SH91900 SPORT PLUS TILT MECHANISM.
- SSC62xx Steering Cable (where xx is length in feet) for Quick Connect Helms (two required for dual helms).
- SSC61xx Steering Cable (where xx is length in feet) for standard helms (two required for dual helms).
- Engine Connection Kit (refer to SeaStar Solutions catalog) Use engine makers kit for dual cable systems.
- Steering Wheel (refer to SeaStar Solutions catalog). Maximum wheel diameter 16", maximum wheel dish 5".

NOTICE

OUTBOARD APPLICATIONS: This system is only recommended as replacement for the original system as installed by the boat manufacturer. SeaStar Solutions always recommends NFB™ (or No Feed Back) helms for outboard applications. NFB™ helms lock out steering loads caused by propeller torque eliminating the driver fatigue normally experienced with a standard helm. Patented SeaStar Solutions NFB™ steering helms are a drop in replacement for Safe-T® systems.

NOTICE

When replacing an existing steering system it is recommended that you stay with the style (rotary or rack) the boat manufacturer installed. Never change your steering from a dual cable to a single cable system, as this could cause an unsafe boating condition.

⚠ WARNING

Before starting installation read these instructions and engine makers instructions thoroughly. Failure to follow either of these instructions or incorrect assembly can result in loss of control and cause property damage, injury, or death.

⚠ WARNING

DO NOT substitute parts from other manufacturers, they may cause a safety hazard for which SeaStar Solutions cannot accept responsibility. Use only SeaStar Solutions steering cables with this helm.

⚠ WARNING

To avoid excessive steering loads, and to get the best steering performance, the outboard motor or outdrive trim tabs and tilt position must be adjusted as instructed in the motor manufacturers operation manual. Failure to do so can effect the performance of the boat and its safe operation which may cause property damage, injury, or death.

⚠ WARNING

DO NOT attach any electrical ground wires to the helm. This would result in an electrolytic reaction to the steering system that may result in system failure or greatly reduced service life.

NOTICE

Helms and cable assemblies are supplied lubricated ready for installation, do not add any lubricant to either assembly. Use of other lubricants can cause damage to the steering cable, resulting in the cable seizing or premature wear. Keep the cable and drive assembly clean during installation. Dirt will damage the system and cause premature wear. Do not take the plastic sleeve off the end of the cable until you are ready to install it into the helm.

This notice does not include the engine output ram end of the cable.

⚠ WARNING

Helms must not be disassembled for any reason. Failure to reassemble correctly may lead to total failure of the system, which could result in property damage, injury, or death.

Preparation for Installation

STEP 1. Locate the position for the steering wheel on the console or dashboard. The steering cable can enter the helm from either port or starboard.

⚠ CAUTION

Ensure that the clearances shown in figures 1 & 2 are maintained and that the steering wheel does not interfere with other dashboard equipment such as engine controls and instruments.

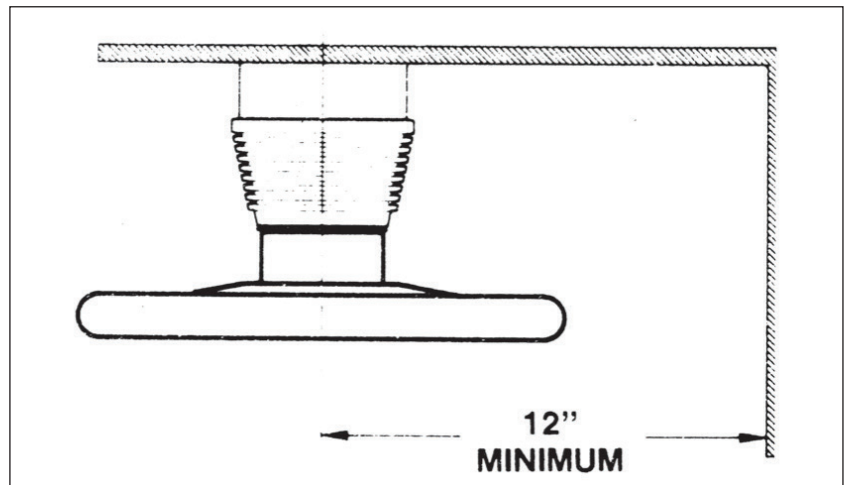

Figure 1.

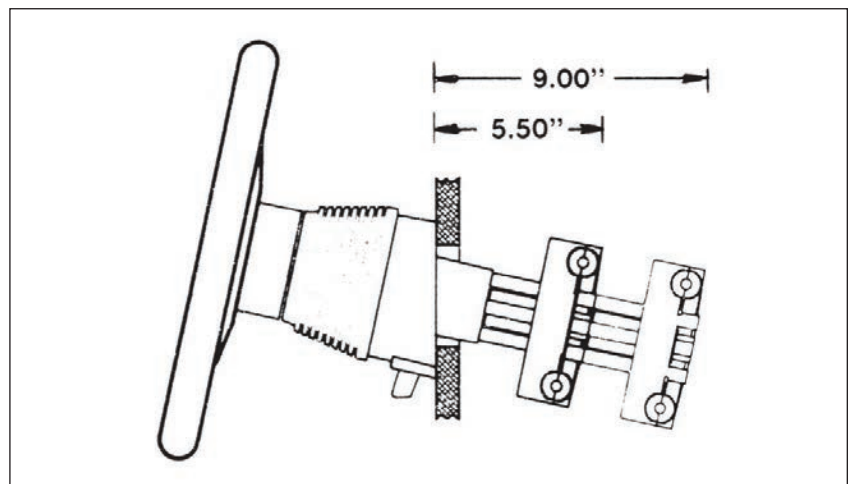

Figure 2.

STEP 2. Position the template (figure 3) on the console or dashboard at the location previously marked, and drill three holes 5/16" diameter and one hole 2-7/8" diameter.

Helm Mounting Bracket Installation

Referring to figure 3, below: Secure the helm mounting plate (item 3) in position using three each of the 2-1/8" long hex bolts (item 4), large OD flat washers (item 6), and locknuts (item 8). Be sure the washers are on the inside of the dash as shown. Tighten securely.

Items 3, 4, 6 & 8 are included with Tilt Mechanism.

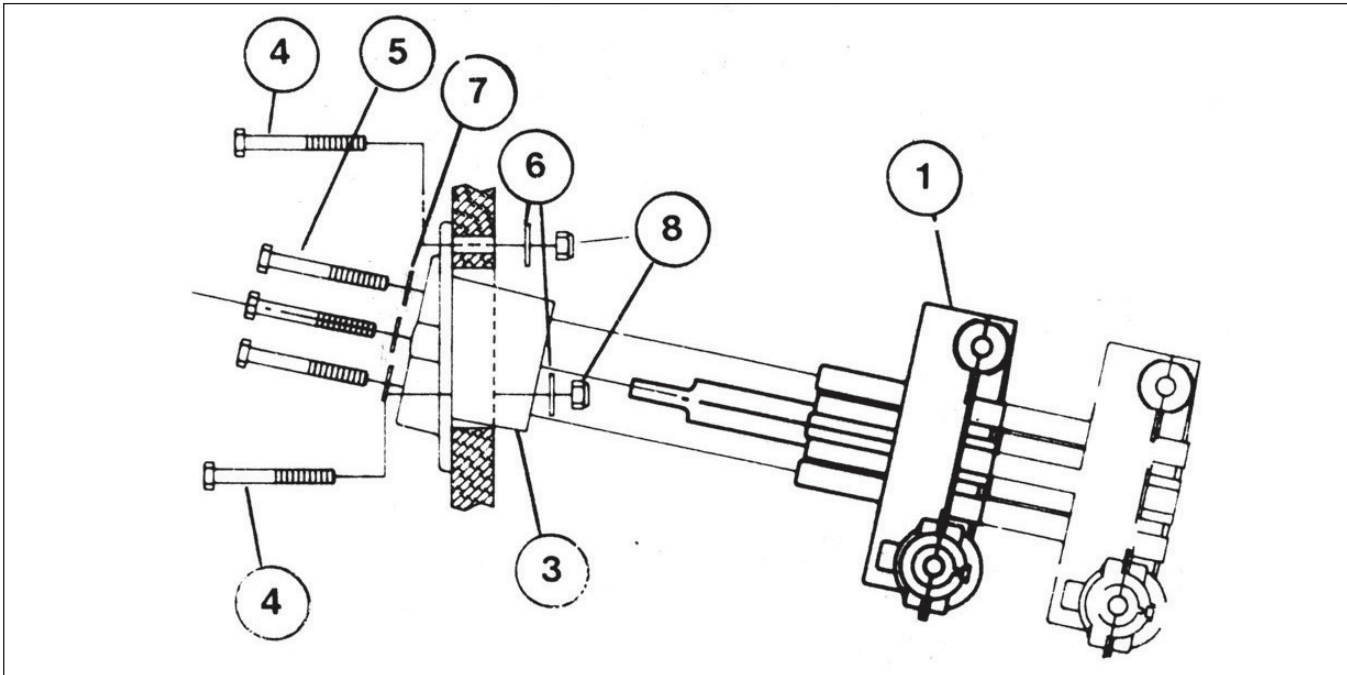

Figure 4.

Steering Cable Routing

Before the helm can be attached to the mounting bracket, the routing of the steering cable must be determined.

The helm assembly can be mounted for either port or starboard cable routing. Steering cables, if possible, should be routed to the starboard side of the boat in order to balance engine torque.

When routing the steering cable(s), select a path with the minimum number of bends, making the bends as large as possible. **DO NOT MAKE BENDS OF LESS THAN 8" RADIUS.** Sharp or frequent bends will result in hard steering and premature cable wear. When it is necessary to pass through a bulkhead, a 1-1/2" diameter hole is required. Cable(s) should be loosely clamped or tied for support at regular intervals.

CAUTION

Cables must not be bundled together with electrical wiring.
Cables must not rest on sharp edges which can cause chafing.

Helm Installation

Referring to figure 3, above for the most common applications: Insert shaft of helm (item 1) through hole in the mounting plate so that the helm's cable entry spigot is facing starboard when viewed from the front of the dash. Attach the helm securely to the mounting plate using washers (item 7) and hex bolts (item 5) threaded into the helm.

At this time refer to the instructions packed with the tilt mechanism hardware kit and install the tilt mechanism and the steering wheel.

Steering Cable Installation

Before the steering cable is installed the steering wheel should be positioned as shown in figure 5, so that it is in the correct orientation when the installation is completed.

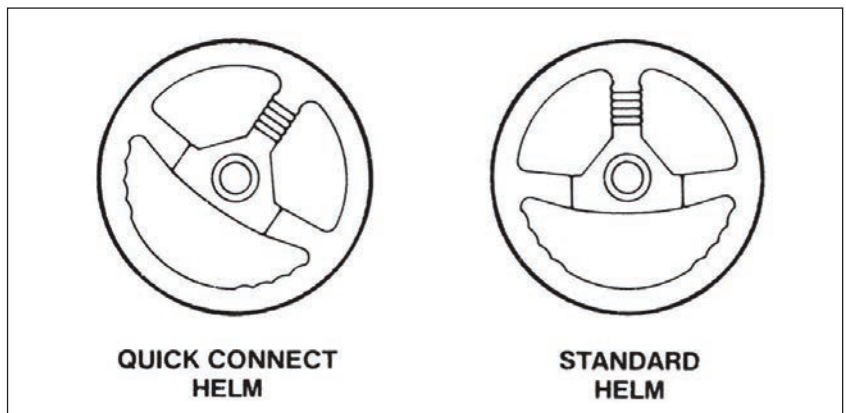

Figure 5.

Single Cable—Quick Connect Helm

Note: If port side cable routing is desired, order helm converter SA27260P and spent travel tube SA38603P to reverse the cable entry spigot location.

STEP 1. Remove the pin from the cable entry of the helm. *Do not remove tag from the pin.* Remove the protective sleeve from the cable end, making sure that no dirt gets on the lubricated cable end.

STEP 2. Feed the cable into the *Lower* helm spigot until it contacts the internal gear. Then turn steering wheel to draw the cable fully into the helm (see Figure 6). Continue turning the steering wheel until the end fitting of the cable is entered into the entry spigot and the steering wheel cannot be turned further. During this you may hear a click as the locking mechanism engages. Turn the steering wheel fully in the other direction until it cannot be turned any further. Check that the cable end fitting is retained inside the entry spigot.

STEP 3. Replace the pin as shown in Figure 7, making sure that it is fully seated. *Do not remove tag from pin.*

STEP 4. Turn the steering wheel fully to both extremes of rotation and check that the cable fitting is retained in the entry spigot.

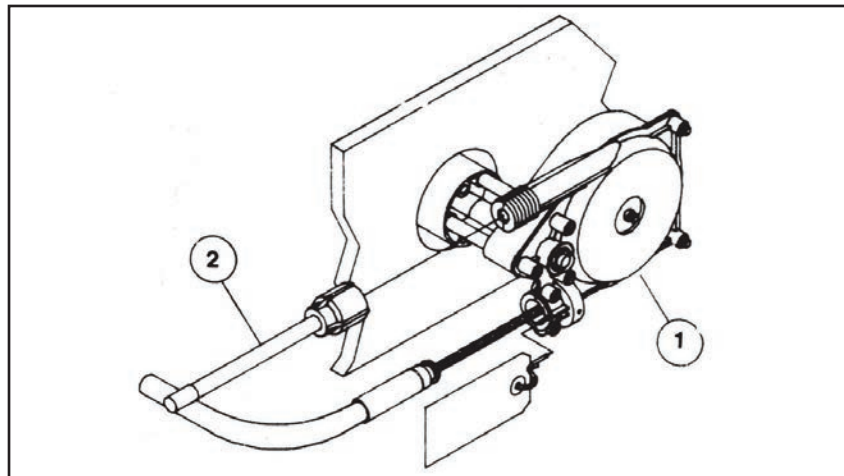

Figure 6.

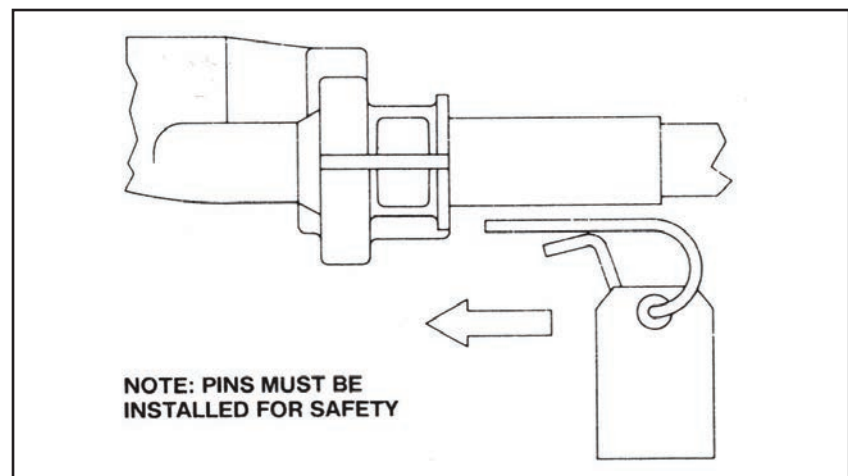

Figure 7.

STEP 5. Feed spent travel tube (item 2) over the exposed cable and thread the Retaining Nut onto spigot. Tighten the nut hand tight.

STEP 6. Rotate the steering wheel several times from stop to stop, and watch the movement of the Steering Cable output rams. On starboard routed cables, turning the steering wheel clockwise should cause the rams to extend. On port routed cables, turning the steering wheel clockwise should cause the rams to retract.

Single Cable—Standard Helm

Refer to QC helm converter instructions (IS-SA27620) packaged with SSC61xx cable.

QC helm converter should be installed to lower helm spigot for standard steering applications.

Connection to Engine

For engine-mounted steering systems, slide the output ram through the engine support tube. Thread the cable coupler nut fully onto the support tube.

For a boat-mounted steering system, attach the cable to the boat and engine in accordance with the instructions furnished with the connection kit.

CAUTION

The output ram end of the steering cable should be lubricated with a good Waterproof Marine Grease before being inserted into the support tube.

NOTICE

The coupler nut has a locking ring in the threads. Make sure the nut is drawn up fully and its internal plastic locking ring is engaged. If you do not tighten this nut fully there will be excessive play in the steering system. Connect the cable output ram to the engine tiller arm as shown in the instructions packed with the connection kit.

CAUTION

Ensure that the cable output end is not bent when installing into the engine. If necessary remove the engine from the boat.

Dual Cable—Quick Connect Helm

Note: If port side cable routing is desired, order helm converter SA27260P and spent travel tube SA38603P (2 each) to reverse the cable entry spigot location.

STEP 1. Remove the pins from the cable entries of the helm. *Do not remove tag from the pins.*

STEP 2. Push both output rams of the cables to the fully retracted position. Make sure that they stay fully retracted during installation into the helm. Remove the protective sleeves from Steering Cables. Make sure that dirt does not get onto the lubricated cable ends. Hold both cables together at the helm end with the faces of the conduit fittings flush, as shown in Figure 8.

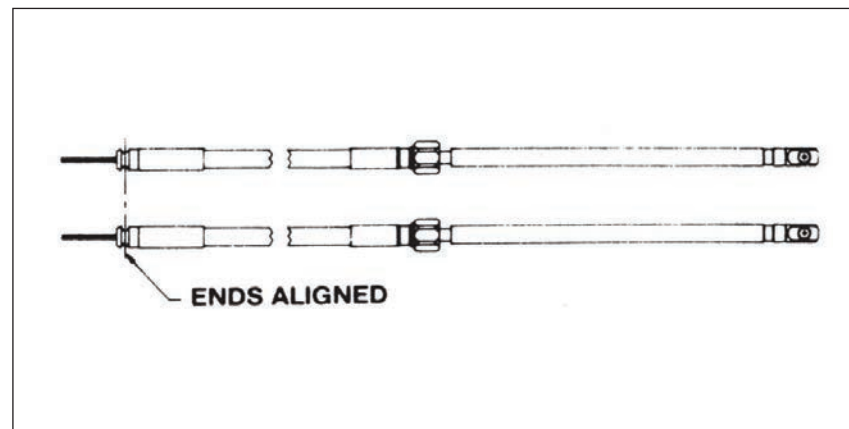

Figure 8.

STEP 3. Feed the cable ends into the *Lower* entry spigots, keeping the conduit fittings aligned, until they contact the internal gears. Then turn the steering wheel to draw the cables fully into the helm. Continue turning wheel until both conduit end fittings are entered into the entry spigots and the steering wheel cannot be turned further. During this you may hear a click as the locking mechanism engages. Turn the steering wheel fully in the other direction until it cannot be turned any further. Check that the cable end fitting is retained inside the entry spigots.

⚠ WARNING

It is possible that one cable may not be fully engaged at this time. Check that both cables are fully engaged by pushing each cable fully home, to seat them properly.

STEP 4. Replace the pins as shown in Figure 7, making sure that they are fully seated. If one pin cannot be inserted, that cable is not fully seated in the helm. Push on the cable to ensure that it is fully home. Replace pins as shown in Figure 7. *Do not remove tags from pins.*

STEP 5. Feed the Spent Travel Tubes (item 2) over the exposed cable ends and thread the Retaining Nuts onto spigots. Tighten nuts hand tight.

STEP 6. Rotate the steering wheel several times from stop to stop, and watch the movement of the Steering Cable output rams. On starboard routed cables, turning the steering wheel clockwise should cause the rams to extend. On port routed cables, turning the steering wheel clockwise should cause the rams to retract.

Dual Cable—Standard Helm

Refer to QC helm converter instructions (IS-SA27620) packaged with SSC61xx cable.

QC helm converters should be installed to lower helm spigots for standard steering applications.

Connection to Engine

The steering cables can now be connected to the engine, using a connection kit available from the engine maker or an approved equivalent. The adjustment of dual cable connection kits is critical for smooth easy steering. The instructions provided by the kit maker must be followed.

CAUTION

Ensure that the cable output end is not bent when installing into the engine. If necessary remove the engine from the boat.

Adjustment of the connection kit is critical to the operation of this system. If the instructions are not followed exactly, the steering will be heavy and could be subject to accelerated wear. Adjustments must be made and tested with the boat under operating conditions. To fine tune the steering, install the connection kit without adjusting the second cable tube. Turn the steering wheel so that you get a feel of the load to move the engine. Move the engine from side to side and check the amount of free play in the cables. Adjust the connection kit tube until as much of the free play is removed as possible WITHOUT INCREASING THE LOAD AT THE STEERING WHEEL. There may be a small amount of free play at the steering wheel. This is normal and cannot be removed by adjusting the connection kit. Tighten both adjusting nuts and test drive the boat. Readjust the connection kit if necessary.

Parts List

| ITEM | DESCRIPTION | SINGLE | DUAL |
|------|-----------------------|--------|------|
| 1 | Helm | 1 | 1 |
| 2 | Spent Travel Tube | 1 | 2 |
| 3* | Helm Mounting Bracket | 1 | 1 |
| 4* | Hex Bolt 1/4 x 2 1/8 | 3 | 3 |
| 5 | Hex Bolt 1/4 x 4 1/2 | 3 | 3 |
| 6* | Large Washer | 3 | 3 |
| 7 | Flat Washer | 3 | 3 |
| 8* | Locknut | 3 | 3 |

*Part of tilt mechanism.

Operation & Maintenance Notes

CAUTION

It is possible to over trim the engine and increase the steering torque to the point that the steering wheel cannot be turned, even though the torque is not felt at the wheel. This may give the impression that the steering is “locked”. This condition can occur more when jack plates are used to raise the engine on the transom, and can only be overcome by reducing the boat speed or engine trim out position. Until you are completely familiar with the boat and the effects of power trim, make all adjustments of trim with extreme caution.

1. After a few hours of operation and at frequent intervals thereafter, check all fasteners and the complete steering system for security and integrity.

DANGER

Loosening or loss of one or more fasteners may cause failure of the steering system, resulting in loss of steering control and could cause property damage, injury, or death.

2. Keep all moving parts free from build-up of salt and other foreign material. This will affect their operation and create steering problems. Periodically remove the cable, clean support tube and telescopic end of cable thoroughly and lubricate with a **waterproof marine grease**.
3. Periodically inspect for corrosion. Any parts affected by corrosion must be replaced. When replacing hardware, self-locking hardware as originally supplied must be used.
4. Periodically inspect steering cable for cracks or other damage. If any is found the cable must be replaced.
5. If cable is stiff in operation, it is unsafe to use and must be replaced immediately.

DANGER

DO NOT cover cracks with tape or other sealants, this will create a hazard in which the cable can fail suddenly without warning, resulting in property damage, injury, or death.

NOTICE

Boat builder and boat dealer, please supply these Installation Instructions and Owner's Manual with the delivery of boat. Boat owner keep these instructions with your boat for future reference. Boat owner consult with your boat builder, boat dealer, or SeaStar Solutions if you have any questions regarding these instructions.

Mounting Template

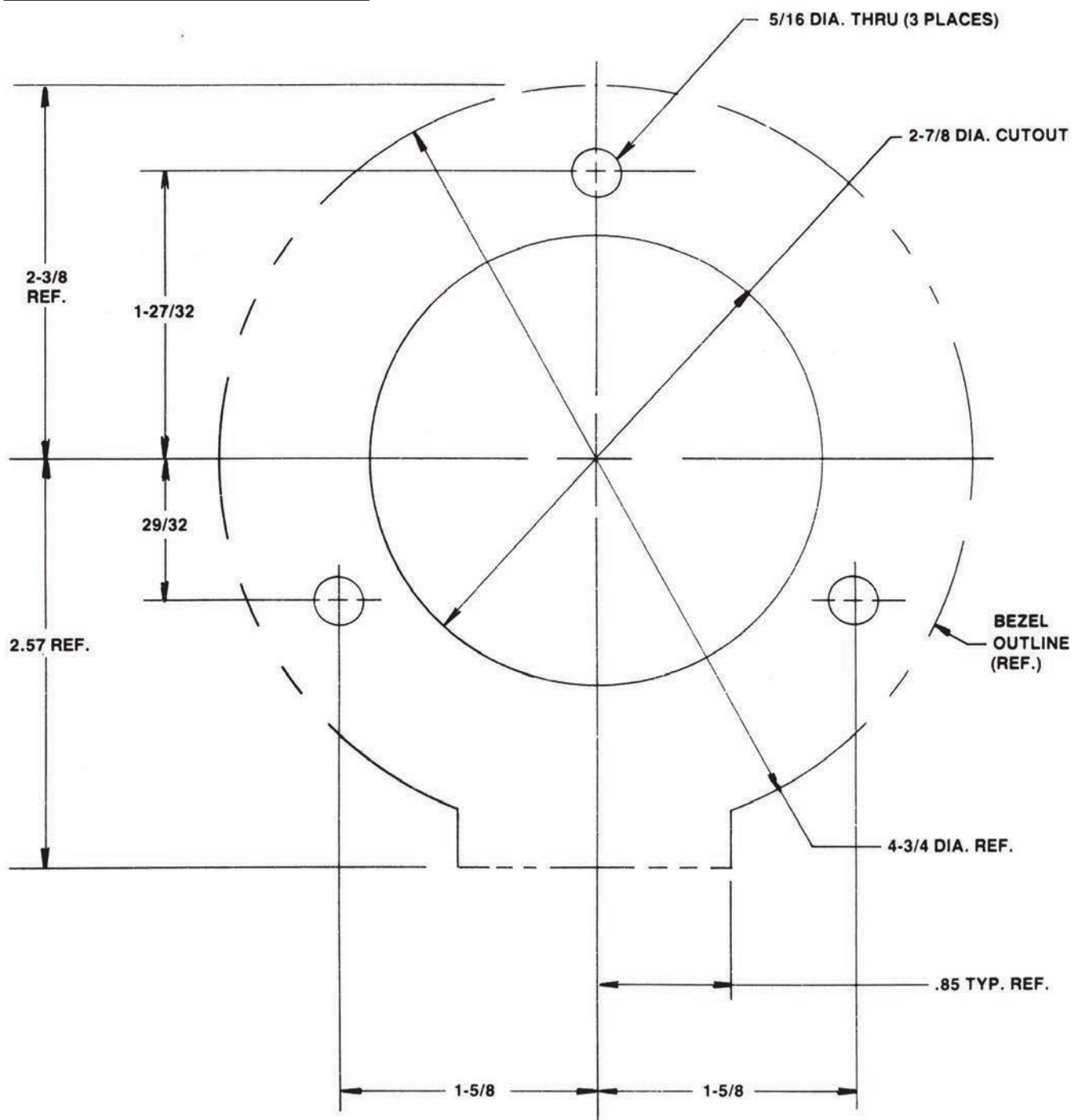

Figure 3.

NOTICE

If you must photocopy this mounting template for use, check ALL measurements using a measuring device prior to using as a template.





**SEASTAR
SOLUTIONS®**

640 North Lewis Road
Limerick, PA 19468 USA
610-495-7011
www.seastarsolutions.com

ISO 8848



© 1998 MARINE ACQUISITION (US) INC.

PART # IS-SH91545, Rev. 2, 07/2013