

MEMBER  
**ABYC**  
Setting Standards for Safer Boating

# INSTALLATION INSTRUCTIONS

## AND OWNERS MANUAL

Part # IS-SH5150/5155, Rev 3, 07/2013

[www.seastarsolutions.com](http://www.seastarsolutions.com)

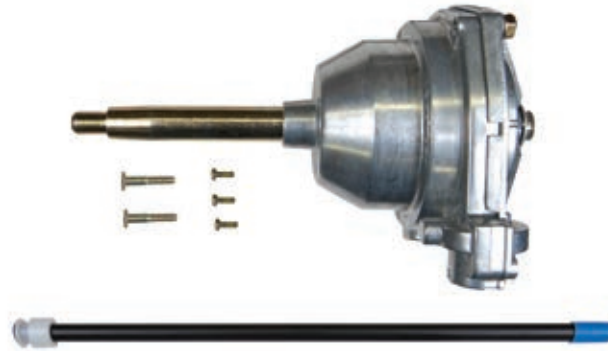

# *safe-t II*

Mechanical Steering for  
Outboard Powered Vessels

NFB™ SAFE-T™ II HELM SH5150/SH5155

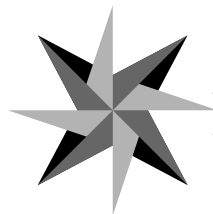

SEASTAR  
SOLUTIONS®

*big-t*  
*jbs*  
*nfb*  
*rack*  
*safe-t*  
*xtreme*

MANUFACTURED BY  
MARINE ACQUISITION INCORPORATED  
DBA SEASTAR SOLUTIONS  
U.S.A.

*Before you do it your way,  
please try it our way.*

# SAFE-T™ II

# NFB™ HELM

## SH5150/SH5155

### NOTICE

*Installer: these instructions contain important safety information and must be forwarded to the boat owner.*

These instructions show you how to install SSC62XX steering cable(s) into SAFE-T™ II NFB™ Helms. NFB™ or No Feed Back helms have a clutch mechanism to prevent engine torque at the steering wheel. This reduces operator fatigue by eliminating the constant fighting of the wheel. The instructions for mounting the helm to the dash are given in the bezel kit instructions.

For a complete SAFE-T™ II NFB™ steering system the following additional components are required.

- Bezel Kit, SB27150 (90°) or SB27483 (20°)
- Steering Cable SSC62xx (where xx is length in feet)
- Engine Connection Kit (refer to SeaStar Solutions catalog)
- Steering Wheel (refer to SeaStar Solutions catalog) Maximum wheel diameter 16", maximum wheel dish 5".

### ⚠ DANGER

**If steering cable is stiff in operation, it is unsafe to use and must be replaced immediately.**

### ⚠ WARNING

**Before starting installation read these instructions and engine makers instructions thoroughly. Failure to follow either of these instructions or incorrect assembly can result in loss of control and cause property damage, injury, or death.**

### ⚠ WARNING

**DO NOT substitute parts from other manufacturers, they may cause a safety hazard for which SeaStar Solutions cannot accept responsibility. Use only SeaStar Solutions steering cables with this helm.**

### ⚠ WARNING

**To avoid excessive steering loads, and to get the best steering performance, the outboard motor or outdrive trim tabs and tilt position must be adjusted as instructed in the motor manufacturers operation manual. Failure to do so can effect the performance of the boat and its safe operation which may cause property damage, injury, or death.**

### ⚠ WARNING

**DO NOT attach any electrical ground wires to the helm. This would result in an electrolytic reaction to the steering system that may result in system failure or greatly reduced service life.**

### ⚠ WARNING

**Helms must not be disassembled for any reason. Failure to reassemble correctly may lead to total failure of the system, which could result in property damage, injury, or death.**

### NOTICE

*When replacing an existing steering system it is recommended that you stay with the style (rotary or rack) the boat manufacturer installed. Never change your steering from a dual cable to a single cable system, as this could cause an unsafe boating condition.*

### NOTICE

*Helms and cable assemblies are supplied lubricated ready for installation, do not add any lubricant to either assembly. Use of other lubricants can cause damage to the steering cable, resulting in the cable seizing or premature wear. Keep the cable and drive assembly clean during installation. Dirt will damage the system and cause premature wear. Do not take the plastic sleeve off the end of the cable until you are ready to install it into the helm.*

*This notice does not include the engine output ram end of the cable.*

## Preparation for Installation

Before the steering cable can be installed, the helm, the bezel, and steering wheel must be fully installed as shown in the bezel kit instructions.

## Steering Cable Routing

The helm assembly can be mounted for either port or starboard cable routing. Steering cables, if possible, should be routed to the starboard side of the boat in order to balance engine torque.

When routing the steering cable, select a path with the minimum number of bends, making the bends as large as possible. **DO NOT MAKE BENDS OF LESS THAN 8" RADIUS.** Sharp or frequent bends will result in hard steering and premature cable wear. When it is necessary to pass through a bulkhead, a 1-1/2" diameter hole is required. Cable should be loosely clamped or tied for support at regular intervals.

### **CAUTION**

**Cables must not be bundled together with electrical wiring.**

**Cables must not rest on sharp edges which can cause chafing.**

## Steering Cable Installation

Before the steering cable is installed the steering wheel should be positioned as shown in Figure 1, so that it is in the correct orientation when installation is completed.

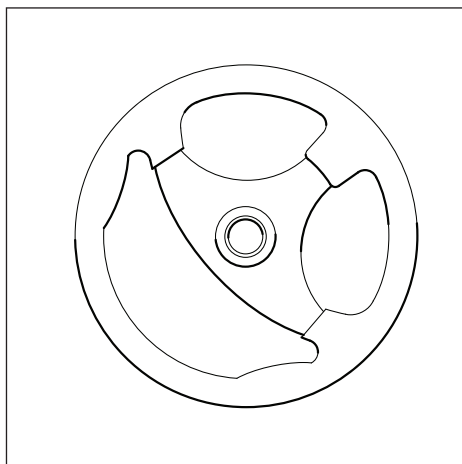

Figure 1.

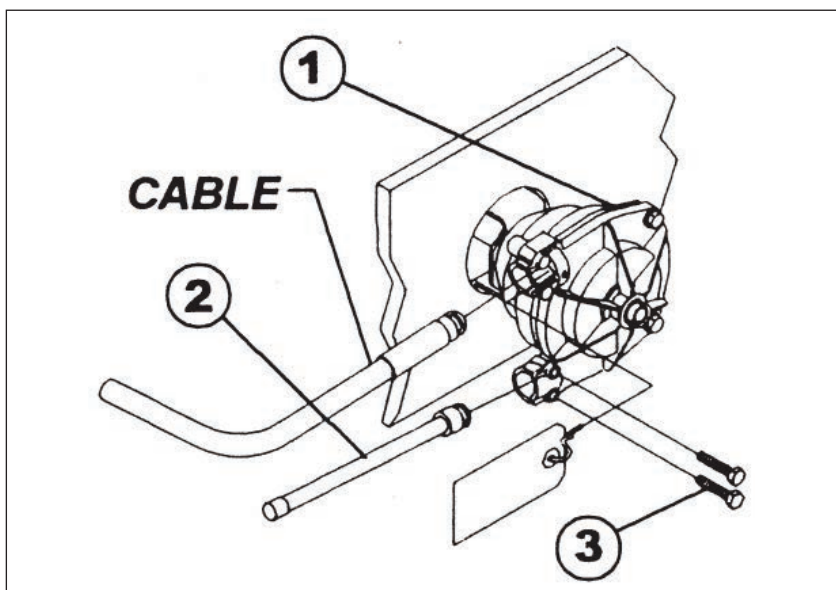

Figure 2.

## Parts List

ITEM	DESCRIPTION	QUANTITY
1	Helm	1
2	Spent Travel Tube	1
3	Hex Bolt 1/4 x 1" Long	2
4	Hex Bolt 1/4 x 3/4" Long	3*

\*These bolts to be used to mount the helm to the SB27150/SB27483 Bezel Kit mounting bracket (Follow instructions supplied with bezel kit).

**STEP 1.** Remove pin from cable entry spigot of helm **DO NOT REMOVE TAG FROM PIN.**

**STEP 2.** Remove protective sleeve from cable end, making sure that dirt does not get onto the lubricated cable end. Feed cable end into the **UPPER** Helm entry spigot until it contacts the internal gear, then turn the steering wheel counterclockwise to draw the cable fully into the helm, (see figure 2). Continue turning the steering wheel until the end fitting of the cable is fully inserted into the entry spigot, and wheel cannot be turned further. During this you may hear a click as the locking mechanism engages. Turn steering wheel fully in the other direction until it cannot be turned any further, and check that cable end fitting is retained inside the entry spigot.

**STEP 3.** Replace pin as shown in Figure 3, making sure that it is fully seated. **DO NOT REMOVE TAG FROM PIN.**

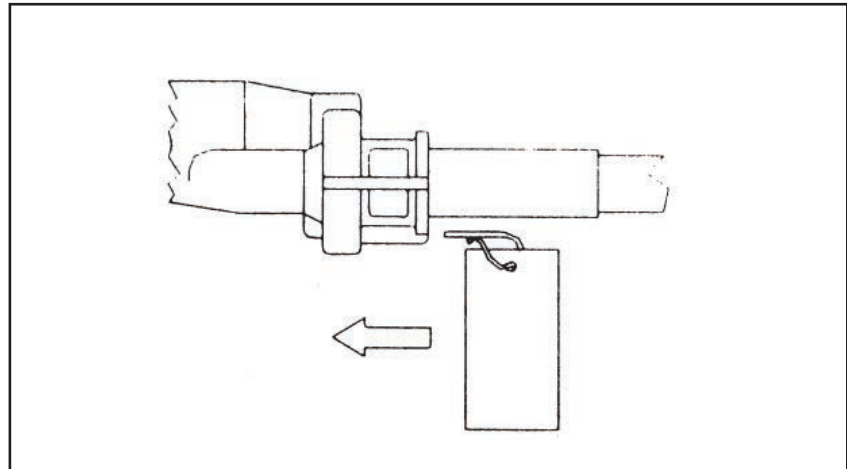

*Figure 3.*

**STEP 4.** Turn steering wheel fully to both extremes of rotation and check that the cable fitting is retained in the entry spigot.

**STEP 5.** Feed spent travel tube (Item 2, Figure 2) over the exposed cable end until it is fully seated in the helm. Secure the tube to the helm with bolts (item 3) and tighten fully.

## Connection to Engine

---

For engine-mounted steering systems, slide the output ram through the engine support tube. Thread the cable coupler nut fully onto the support tube.

For a boat-mounted steering system, attach the cable to the boat and engine in accordance with the instructions furnished with the connection kit.

---

### CAUTION

***The output ram end of the steering cable should be lubricated with a good Waterproof Marine Grease before being inserted into the support tube.***

---

### CAUTION

**Ensure that the cable output end is not bent when installing into the engine. If necessary remove the engine from the boat.**

---

### NOTICE

*The coupler nut has a locking ring in the threads. Make sure the nut is drawn up fully and its internal plastic locking ring is engaged. If you do not tighten this nut fully there will be excessive play in the steering system. Connect the cable output ram to the engine tiller arm as shown in the instructions packed with the connection kit.*

## Operation & Maintenance Notes

### ⚠ CAUTION

It is possible to over trim the engine and increase the steering torque to the point that the steering wheel cannot be turned, even though the torque is not felt at the wheel. This may give the impression that the steering is “locked”. This condition can occur more when jack plates are used to raise the engine on the transom, and can only be overcome by reducing the boat speed or engine trim out position. Until you are completely familiar with the boat and the effects of power trim, make all adjustments of trim with extreme caution.

1. After a few hours of operation and at frequent intervals thereafter, check all fasteners and the complete steering system for security and integrity.

### ⚠ DANGER

**Loosening or loss of one or more fasteners may cause failure of the steering system, resulting in loss of steering control and could cause property damage, injury, or death.**

2. Keep all moving parts free from build-up of salt and other foreign material. This will affect their operation and create steering problems. Periodically remove the cable, clean support tube and telescopic end of cable thoroughly and lubricate with a **waterproof marine grease**.

3. Periodically inspect for corrosion. Any parts affected by corrosion must be replaced. When replacing hardware, self-locking hardware as originally supplied must be used.

4. Periodically inspect steering cable for cracks or other damage. If any is found the cable must be replaced.

### ⚠ DANGER

**If steering cable is stiff in operation, it is unsafe to use and must be replaced immediately.**

### ⚠ DANGER

**DO NOT cover cracks with tape or other sealants, this will create a hazard in which the cable can fail suddenly without warning, resulting in property damage, injury, or death.**

### NOTICE

*Boat builder and boat dealer, please supply these Installation Instructions and Owner's Manual with the delivery of boat. Boat owner keep these instructions with your boat for future reference. Boat owner consult with your boat builder, boat dealer, or SeaStar Solutions if you have any questions regarding these instructions.*



SEASTAR  
SOLUTIONS®

640 North Lewis Road  
Limerick, PA 19468 USA  
610-495-7011  
www.seastarsolutions.com

ISO 8848



© 1998 MARINE ACQUISITION (US) INC.