

2013

NEW & FOCUS PRODUCT

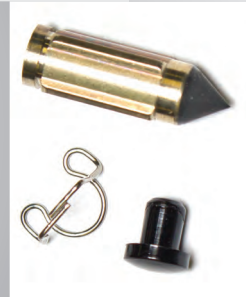

40 YEARS OF EXPERIENCE

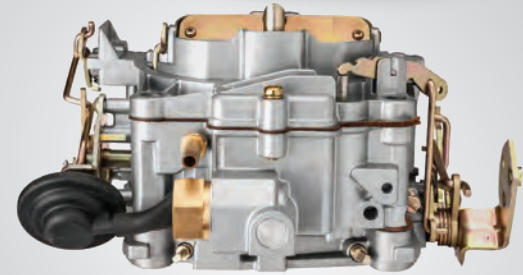

DEALER NETWORK

QUALITY PRODUCTS FOR YOU AND YOUR BOAT

TECHNOLOGY LEADING MARINE PRODUCTS WITH 40 YEARS OF EXPERIENCE



Introducing:

STATS

SIERRA TOUCH AND TEST SYSTEM

STATS is the perfect solution for performing diagnostics on your marine engine. This self contained system requires no additional computer hardware to operate and works with most popular engine brands. The console integrates an easy to use touch screen with a left/right tactile user interface to create an efficient user experience.

- ECU Identification
- Reads Fault Codes
- Clears Fault Codes
- Displays Live Data
- Performs Engine Systems Tests
- Stationary Tests
- Service Info
- Vibration Proof
- Splash Proof
- Service Reset
- Component Actuation
- Internet Software Updates
- Print & Save Service Results
- USB, PC Interface
- Number Of Hours Engine Has Run



18-SD102
STATS Diagnostic System Complete Kit
For: Mercury/Mercuriser/MEFI, BRP, Yamaha, Suzuki



18-SD103
STATS Diagnostic System Complete Kit
For: Mercury/Mercuriser/MEFI, BRP, Yamaha



18-SD104
STATS Diagnostic System Complete Kit
For: Mercury/Mercuriser/MEFI, BRP, Suzuki



18-SD105
STATS Diagnostic System Complete Kit
For: Mercury/Mercuriser/MEFI, Yamaha



18-SD106
STATS Diagnostic System Complete Kit
For: Mercury/Mercuriser/MEFI



18-SD107
STATS Diagnostic System Complete Kit
For: BRP



18-SD108
STATS Diagnostic System Complete Kit
For: Yamaha



18-SD109
STATS Diagnostic System Complete Kit
For: Suzuki



18-SD110
STATS Diagnostic System Complete Kit
For: SeaDoo/Yamaha/Kawasaki

NEW PRODUCT - 2013



18-ADA500
STATS Tester (Console)



18-ADA501
STATS Carry Case



18-ADA502
STATS Tester (Console)
Neoprene Case



18-ADA503
STATS Dongle Case



18-ADA504
STATS Yamaha Neoprene
Carry Case



18-ADA505
STATS Mercury/Mercruiser/
MEFI Carry Case



18-ADA506
STATS BRP/Seadoo
Neoprene Carry Case



18-ADA507
STATS Kawasaki Neoprene
Carry Case



18-ADA508
STATS Suzuki Neoprene
Carry Case

NEW PRODUCT - 2013



18-ADC400
STATS Dongle A Universal



18-ADC401
STATS Dongle B Seadoo 4
Tech Engines



18-ADC409
STATS Dongle C Seadoo DI
Engines



18-ADC412
STATS Dongle D BRP
DESS (2 Stroke)



18-ADC152
STATS Power Cable (AC)



18-ADC450
STATS Power Cable (12v)



18-ADC153
STATS USB Cable



18-ADC300
STATS Master Cable



18-ADC402
STATS BRP Safety Key
Programming Cable

NEW PRODUCT - 2013



18-ADC403
STATS Yamaha
Diagnostic Cable



18-ADC404
STATS BRP
Diagnostics Cable



18-ADC406
STATS Kawasaki
T-In Power Cable



18-ADC407
STATS Mercury
Diagnostic Cable



18-ADC408
STATS BRP
T-In Power Cable



18-ADC410
STATS Mercury
Outboard Cable



18-ADC414
STATS Kawasaki
Power Cable (4-Stroke)



18-ADC416
STATS Kawasaki
Fitch DI Cable



18-ADC418
STATS Yamaha
Remote Programming Cable



18-ADC419
STATS Kawasaki
Key Programming Cable



18-ADC420
STATS Suzuki
4 Pin Diagnostic Cable



18-ADC421
STATS Suzuki
8 Pin Diagnostic Cable



18-ADC422
STATS BRP
DESS Diagnostic Cable



18-ADC423
STATS Johnson Evinrude
Diagnostic Cable



18-ADC424
STATS Mercruiser / MEFI
Diagnostic Cable

NEW PRODUCT - 2013

COMPLETE KITS

18-SD102	Mercury/Mercruiser/MEFI, BRP, Yamaha, Suzuki Diagnostic System Complete Kit
18-SD103	Mercury/Mercruiser/MEFI, BRP, Yamaha Diagnostic System Complete Kit
18-SD104	Mercury/Mercruiser/MEFI, BRP, Suzuki Diagnostic System Complete Kit
18-SD105	Mercury/Mercruiser/MEFI, Yamaha Diagnostic System Complete Kit
18-SD106	Mercury/Mercruiser/MEFI Complete Kit
18-SD107	BRP Diagnostic System Complete Kit
18-SD108	Yamaha Diagnostic System Complete Kit
18-SD109	Suzuki Diagnostic System Complete Kit
18-SD110	SeaDoo/Yamaha/Kawasaki Diagnostic System Complete Kit

CONSOLE

18-ADA500	STATS Tester (Console)
------------------	------------------------

CARRYING CASES

18-ADA501	STATS Carry Case
18-ADA502	STATS Tester (Console) Neoprene Case
18-ADA503	STATS Dongle Case
18-ADA504	STATS Yamaha Neoprene Carry Case
18-ADA505	STATS Mercury/Mercruiser/MEFI Carry Case
18-ADA506	STATS BRP/Seadoo Neoprene Carry Case
18-ADA507	STATS Kawasaki Neoprene Carry Case
18-ADA508	STATS Suzuki Neoprene Carry Case

DONGLES

18-ADC400	Dongle A Universal
18-ADC401	Dongle B Seadoo 4 Tech Engines
18-ADC409	Dongle C Seadoo DI Engines
18-ADC412	Dongle D BRP DESS (2 Stroke)

CABLES

18-ADC152	Power Cable (AC)
18-ADC450	Power Cable (12v)
18-ADC153	USB Cable
18-ADC300	Master Cable
18-ADC402	BRP Safety Key Programming Cable
18-ADC403	Yamaha Diagnostic Cable
18-ADC404	BRP Diagnostics Cable
18-ADC406	Kawasaki T-In Power Cable
18-ADC407	Mercury Diagnostic Cable
18-ADC408	BRP T-In Power Cable
18-ADC410	Mercury Outboard Cable
18-ADC414	Kawasaki Power Cable(4-Stroke)
18-ADC416	Kawasaki Fitch DI Cable
18-ADC418	Yamaha Remote Programming Cable
18-ADC419	Kawasaki Key Programming Cable
18-ADC420	Suzuki 4 Pin Diagnostic Cable
18-ADC421	Suzuki 8 Pin Diagnostic Cable
18-ADC422	BRP DESS Diagnostic Cable
18-ADC423	Johnson Evinrude Diagnostic Cable
18-ADC417	Yanmar Cable

Teleflex Marine Gauge Kits

Teleflex Marine is introducing 16 new gauge kits giving you more options to refresh the look of the boat's dash with crisp, clean, stylish, high quality gauges. Eight of the new kits include a Tach/Hourmeter instead of a regular Tachometer. The other eight kits are for dual engine applications. We eliminate the fuel and speedometer from the kit and include only the parts needed for second engine monitoring.

AMEGA



Hottest selling black dial line! Amega® Domed has clean-looking black dials with white and red graphics plus through-dial and perimeter lighting for great readability. Amega has been very popular, available in several styles since its debut in 1986.

FEATURES:

- Black dial, red graduations, white numerals, vivid white pointer staff.
- Scratch resistant curved glass lenses, with black, near-flush bezels.
- U.S. and metric scales, with ISO symbols, where appropriate.
- Perimeter and thru-dial lighting.
- A comprehensive array of outboard water pressure instrument kits.
- Optional add-on square bezels for modular appearance (See Gauge Accessories for details).

Twin Engine Add On IB/IO Gauge Kit	Contains: Tach, Water Temp., Oil pressure, Voltmeter	4 Gauge Set	69722P
Twin Engine Add On OB Gauge Kit	Contains: Tach, Voltmeter	2 Gauge Set	69721P
Instrument Set OB w/ Tach/Hr	Contains: Tach/Hr., Speedo 65 MPH, Fuel Gauge, Voltmeter	4 Gauge Set	69708P
Instrument Set IB/IO w/ Tach/Hr	Contains Tach/Hr, Speedo 65 MPH, Fuel, Water temp, Oil pressure, Voltmeter	6 Gauge Set	69709P

ARCTIC



Stylish white bezel design, black on white graphics, accurate and reliable, these tough instruments look good on all types of boats. Domed glass sheds water and resists scratching.

FEATURES:

- Instruments available for most outboards, stern drives and gasoline-powered inboards.
- Scratch-resistant domed glass lenses.
- Enhanced illumination: through-dial and perimeter lighting for excellent readability at night.
- Low-range speedometers.
- U.S. and metric scales, with ISO symbols, where appropriate.
- Optional add-on square bezels for modular appearance (See Gauge Accessories for details).

Instrument Set OB w/ Tach/Hr	Contains: Tach/Hr., Speedo 65 MPH, Fuel Gauge, Voltmeter	4 Gauge Set	69710P
Instrument Set IB/IO w/ Tach/Hr	Contains Tach/Hr, Speedo 65 MPH, Fuel, Water temp, Oil pressure, Voltmeter	6 Gauge Set	69711P
Twin Engine Add On IB/IO Gauge Kit	Contains: Tach, Water Temp., Oil pressure, Voltmeter	4 Gauge Set	69724P
Twin Engine Add On OB Gauge Kit	Contains: Tach, Voltmeter	2 Gauge Set	69723P

ECLIPSE

Smart white and blue graphics on a black dial background, these very low profile bezels follow the curve of the lense to eliminate water trapping. Design with domed glass sheds water and resists scratching.

FEATURES:

- Instruments available for most outboards, stern drives and gasoline-powered inboards.
- Scratch-resistant domed glass lenses.
- Perimeter lighting for excellent readability at night.
- U.S. and metric scales, with ISO symbols, where appropriate.
- Optional add-on square bezels for modular appearance (See Gauge Accessories for details).



Twin Engine Add On IB/IO Gauge Kit Contains: Tach, Water Temp., Oil pressure, Voltmeter	4 Gauge Set	69726P
Twin Engine Add On OB Gauge Kit Contains: Tach, Voltmeter	2 Gauge Set	69725P
Instrument Set OB w/ Tach/Hr Contains: Tach/Hr., Speedo 65 MPH, Fuel Gauge, Voltmeter	4 Gauge Set	69712P
Instrument Set IB/IO w/ Tach/Hr Contains Tach/Hr, Speedo 65 MPH, Fuel, Water temp, Oil pressure, Voltmeter	6 Gauge Set	69713P

SAHARA

With crisp tan dials and fire-orange pointer tip, Sahara gives any dash the elegant OEM look. Combined red through-dial and white perimeter lighting provide great night readability. These aren't merely "close enough" — they're the real thing!

FEATURES:

- Tan dial and retainer, black graduations and numerals, black pointer with fire-orange tip.
- Scratch resistant curved glass lenses, with black matte, near-flush bezels.
- White perimeter and red thru-dial lighting.
- U.S. and metric scales, with ISO symbols, where appropriate.
- Optional add-on square bezels for modular appearance (See Gauge Accessories for details).

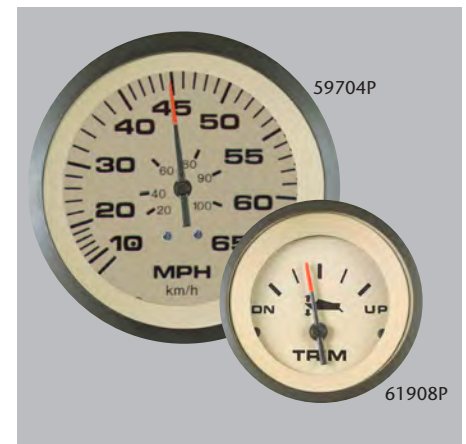

Twin Engine Add On IB/IO Gauge Kit Contains: Tach, Water Temp., Oil pressure, Voltmeter	4 Gauge Set	69717P
Twin Engine Add On OB Gauge Kit Contains: Tach, Voltmeter	2 Gauge Set	69716P
Instrument Set OB w/ Tach/Hr Contains: Tach/Hr., Speedo 65 MPH, Fuel Gauge, Voltmeter	4 Gauge Set	69703P
Instrument Set IB/IO w/ Tach/Hr Contains Tach/Hr, Speedo 65 MPH, Fuel, Water temp, Oil pressure, Voltmeter	6 Gauge Set	69704P
Tach/Hourmeter 0-7000 RPM	3" 0-7000 RPM, O/B ALT./Coil	69743P



69741P

Digital Analog Converter

Our module converts the digital output of new NEMA 2000 outboard motors to analog signals. This eliminates the need to replace the boats current analog gauges with expensive OEM digital gauges.

The DAC will work with motors from Yamaha, Honda, Suzuki and BRP (Johnson/Evinrude).



56968P

Small Engine Hourmeter

Replaces: Yamaha ENG-METER-2C-01
Allows hour monitoring for even the smallest gasoline motors. Great for 2 or 4 stroke. No power or ground required. Water and shock proof. Automatically turns on and off with the engine. Displays up to 9999 hours. 10 year internal battery lifetime.



56969P

Small Engine Tach/Hourmeter

For any gasoline motor up to 2 cylinder. Displays RPM up to 9000. Allows hour monitoring for even the smallest outboard motors. Great for 2 or 4 stroke. Displays RPM when running total hours when off. No power or ground required. Water and shock proof. Automatically turns on and off with the engine. Displays up to 9999 hours. 10 year internal battery lifetime.



18-1653

Shut Off Valve

2 way 1/4" FNPT Female/Female
Universal



18-1652

Shut Off Valve

2 way 1/4" FNPT Male/Female
Universal



18-1651

Shut Off Valve

2 way 1/4" FNPT Male/Male
Universal



18-1650
Valve

3 way 1/4" FNPT
Universal



18-1655

Valve w/ Detent

3 way 1/4" FNPT
Universal

18-1656

Valve w/ Detent

3 way 3/8" FNPT
Universal



18-1654

Valve w/ Detent

4 way 1/4" FNPT
Universal

NEW PRODUCT - 2013



18-8844-1
Wire Set

Replaces: Crusader
Fits: 454/502 XL Series (Straight boot on Plug End)



RK19680
Rocker Switch
On-Off SPST BLK
Universal



RK19680TP
Rocker Switch
On-Off SPST BLK/GR
Universal



RK19690
Rocker Switch
On-Off-On SPDT BLK
Universal



RK19690TP
Rocker Switch
On-Off-On SPDT BLK/GR
Universal



TG23030
Toggle Switch
(On)-Off SPST
Universal

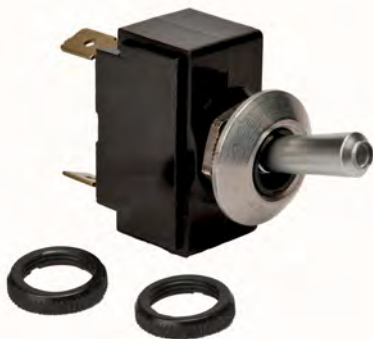

TG23000
Toggle Switch
On-Off SPST
Universal



TG23020
Toggle Switch
On-Off-On DPDT
Universal



TG23040
Toggle Switch
(On)-Off-(On) SPDT
Universal

NEW PRODUCT - 2013



TG23010
Toggle Switch
On-Off-On SPDT
Universal



23-3314
Impeller Kit
Replaces: Kohler 359978
Fits: Kohler Pump GM28487; Fits Models 4EF, 5E, 6EF, 7.3E, 4 EFCDD, 5 ECD, 6 EFCDD, 7.3 ECD,



23-4005
Sea Water Pump Belt
Replaces: Westerbeke 13810
Fits: 32.0 BED(60Hz) / 25.0 BED(50Hz), 32.0 BEDA(60Hz) / 25.0 BEDA(50Hz), 32.0 BEDB(60Hz) / 25.0 BEDB(50Hz)



23-4006
Sea Water Pump Belt
Replaces: Westerbeke 31152
Fits: 20.0 BED(60Hz) / 16.0 BED(50Hz), 20.0 BEDA(60Hz) / 16.0 BEDA(50Hz), 20.0 WTA(60Hz) / 16.0 WTA(50Hz), 25.0 BED(60Hz) / 20.0 BED(50Hz)



23-4007
Sea Water Pump Belt
Replaces: Westerbeke 30376
Fits: 4.0 BCD(60Hz), 4.4 BCD(60Hz), 4.4 WMD(60Hz) / 3.3 WMD(50Hz), 5.0 BCD/BCDA/BCDB(60Hz) / 4.0 BCD/BCDA/BCDB(50Hz)



23-2004
Impeller
Replaces: Kohler 359978 (Impeller Only)
Fits: Kohler Pump GM28487; Fits Models 4EF, 5E, 6EF, 7.3E, 4 EFCDD, 5 ECD, 6 EFCDD, 7.3 ECD,



23-2005
Impeller
Replaces: Northern Lights 25-12009 (Impeller Only)

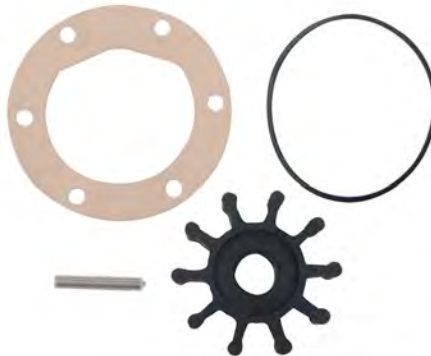

23-3315
Impeller Kit
Replaces: Northern Lights 25-12009
Fits: M673LD3, M673L3, M673LD2, M673L2



23-0400
Quad Ring
Replaces: Northern Lights



23-4000
Alternator Belt

Replaces: Westerbeke 39181
Fits: 20.0 BED(60Hz) / 16.0 BED(50Hz), 20.0 BEDA(60Hz) / 16.0 BEDA(50Hz), 25.0 BED(60Hz) / 20.0 BED(50Hz)



23-4001
Alternator Belt

Replaces: Westerbeke 11672
Fits: 15.0 BTDA(60Hz) / 12.0 BTDA(50Hz), 15.0 BTDB(60Hz) / 12.0 BTDB(50Hz), 20.0 WTA(60Hz) / 16.0 WTA(50Hz)



23-4002
Alternator Belt

Replaces: Westerbeke 30592
Fits: 6.5 TWG(60Hz)/4.9 TWG(50Hz), 8.0 TWG(60Hz)/6.4 TWG(50Hz), 11.0 TWG(60Hz)/8.5 TWG(50Hz), 6.0 BCD(60Hz) / 4.5 BCD(50Hz), 7.7 WMD(60Hz) / 5.8 WMD(50Hz), 8.0 WMD(60Hz) / 6.0 WMD(50Hz), 11.0 BTD(60Hz) / 8.3 BTD(50Hz)



23-4003
Alternator Belt

Replaces: Westerbeke 45232
Fits: 7.6 BTD(60Hz) / 5.7 BTD(50Hz), 8.0 BTDA(60Hz) / 6.0 BTDA(50Hz), 10.0 BTDA(60Hz) / 7.5 BTDA(50Hz), 12.5 BTDB(60Hz) / 9.4 BTDB(50Hz), 15.0 BTDC(60Hz) / 12.0 BTDC(50Hz)



23-4004
Alternator Belt

Replaces: Westerbeke 30475
Fits: 12.5 BTG(60Hz)/10.0 BTG(50Hz), 15.0 BTG/A(60Hz)/12.0 BTG/A(50Hz), 8.0 BTD(60Hz) / 6.0 BTD(50Hz), 10.0 BTD(60Hz) / 7.5 BTD(50Hz), 12.5 BTD(60Hz) / 9.4 BTD(50Hz), 12.5 BTDA(60Hz) / 9.4 BTDA(50Hz), 12.5 WMD(60Hz) / 9.4 WMD(50Hz), 15.0 BTD(60Hz) / 12.0 BTD(50Hz)



23-1104
Air Filter

Replaces: Fischer Panda IC78.460.000B
Fits: PMS 4200, PMS04, PMS15, PMS 16 DP, PMS 20, PMS 22



23-1105
Air Filter

Replaces: Fischer Panda IC78.460.000A
Fits: PMS 8 Mini, PMS 8 DP, PMS 6500, PMS 12 DP, PMS 12 Mini



23-1102
Air Filter Element

Replaces: Northern Lights 24-22009
Fits: M843NW3: 12/10Kw, M844W3: 16/12KW, M844LW3: 20/16Kw



23-1103
Air Filter Element

Replaces: Northern Lights 24-28003
Fits: M673LD3: 5 / 4.5Kw, M673L3: 6/5Kw



23-0830
Thermostat Gasket

Replaces: Northern Lights 11-10015
Fits: Used with 35-12500 and 35-11000 thermo-
stats



23-4500
Plug Wire Set

Replaces: Westerbeke 43060
Fits: 4.5 BCGB(60Hz)/3.75 BCGB(50Hz),
4.5 BCGTC(60Hz)/3.75 BCGTC(50Hz),
4.5 BCGTE(60Hz)/3.75 BCGTE(50Hz), 5.0
BCG(60Hz)/4.2 BCG(50Hz), 5.0 BCGA(60Hz)/5.2
BCGA(50Hz), 7.0 BCGB(60Hz)/6.0 BCGB(50Hz),
7.0 BCGC(60Hz)/5.9 BCGC(50Hz), 7.0
BCGD(60Hz)/5.8 BCGD(50Hz), 7.2
BCGTC(60Hz)/6.0 BCGTC(50Hz), 9.6
BCGTC(60Hz)/8.0 BCGTC(50Hz), 9.6
BCGTE(60Hz)/8.0 BCGTE(50Hz)



23-4501
Plug Wire Set

Replaces: Westerbeke 46596
Fits: 8.0 BEG(60Hz)/6.4 BEG(50Hz), 10.0
BEG(60Hz)/8.0 BEG(50Hz), 12.5 BEG(60Hz)/10.0
BEG(50Hz), 15.0 BEG(60Hz)/12.0 BEG(50Hz),
8.0 SBEG(60Hz) / 6.4 SBEG(50Hz), 10.0
SBEG(60Hz) / 8.0 SBEG(50Hz), 12.5
SBEG(60Hz) / 10.0 SBEG(50Hz), 14.0
SBEG(60Hz) / 11.6 SBEG(50Hz)



23-2700
Distributor Cap

Replaces: Westerbeke 40859
Fits: 20.0 BEG(60Hz)/16.0 BEG(50Hz), 25.0
BEG(60Hz)/20.0 BEG(50Hz), 20.0 SBEG(60Hz)
/ 16.0 SBEG(50Hz), 20.0 SBEGA(60Hz) /
16.0 SBEG(50Hz), 22.5 SBEG(60Hz) / 18.7
SBEG(50Hz), 22.5 SBEGA(60Hz) / 18.7
SBEGA(50Hz)



23-2701
Distributor Cap

Replaces: Westerbeke 34113
Fits: 6.5 TWG(60Hz)/4.9 TWG(50Hz), 8.0
TWG(60Hz)/6.4 TWG(50Hz), 11.0 TWG(60Hz)/8.5
TWG(50Hz), 8.5 BTG(60Hz)/6.5 BTG(50Hz),
12.5 BTG(60Hz)/10.0 BTG(50Hz), 15.0 BTG/
A(60Hz)/12.0 BTG/A(50Hz)



23-2702
Distributor Cap

Replaces: Westerbeke 35608
Fits: 6.5 BCG(60Hz)/4.8 BCG(50Hz), 9.0
BTG(60Hz)/7.0 BTG(50Hz)



23-2703
Distributor Cap

Replaces: Westerbeke 46592
Fits: 8.0 BEG(60Hz)/6.4 BEG(50Hz), 10.0
BEG(60Hz)/8.0 BEG(50Hz), 12.5 BEG(60Hz)/10.0
BEG(50Hz), 15.0 BEG(60Hz)/12.0 BEG(50Hz),
8.0 SBEG(60Hz) / 6.4 SBEG(50Hz), 10.0
SBEG(60Hz) / 8.0 SBEG(50Hz), 12.5
SBEG(60Hz) / 10.0 SBEG(50Hz), 14.0
SBEG(60Hz) / 11.6 SBEG(50Hz)



23-2800
Rotor

Replaces: Westerbeke 34093
Fits: 6.5 TWG(60Hz)/4.9 TWG(50Hz), 8.0
TWG(60Hz)/6.4 TWG(50Hz), 8.5 BTG(60Hz)/6.5
BTG(50Hz), 11.0 TWG(60Hz)/8.5 TWG(50Hz),
12.5 BTG(60Hz)/10.0 BTG(50Hz), 15.0 BTG/
A(60Hz)/12.0 BTG/A(50Hz)



23-2801
Rotor

Replaces: Westerbeke 35610
Fits: 4.0 BCG(60Hz)/3.0 BCG(50Hz)

NEW PRODUCT - 2013



23-2802
Rotor

Replaces: Westerbeke 40860
Fits: 20.0 BEG(60Hz)/16.0 BEG(50Hz), 25.0 BEG(60Hz)/20.0 BEG(50Hz), 20.0 SBEG(60Hz) / 16.0 SBEG(50Hz), 20.0 SBEGA(60Hz) / 16.0 SBEG(50Hz), 22.5 SBEG(60Hz) / 18.7 SBEG(50Hz), 22.5 SBEGA(60Hz) / 18.7 SBEGA(50Hz)



23-2803
Rotor

Replaces: Westerbeke 43050
Fits: 4.5 BCGB(60Hz)/3.75 BCGB(50Hz), 4.5 BCGTC(60Hz)/3.75 BCGTC(50Hz), 5.0 BCG(60Hz)/4.2 BCG(50Hz), 5.0 BCGA(60Hz)/5.2 BCGA(50Hz), 7.0 BCGB(60Hz)/6.0 BCGB(50Hz), 7.0 BCGC(60Hz)/5.9 BCGC(50Hz), 7.2 BCGTC(60Hz)/6.0 BCGTC(50Hz), 8.0 BEG(60Hz)/6.4 BEG(50Hz), 9.6 BCGTC(60Hz)/8.0 BCGTC(50Hz), 10.0 BEG(60Hz)/8.0 BEG(50Hz), 12.5 BEG(60Hz)/10.0 BEG(50Hz), 15.0 BEG(60Hz)/12.0 BEG(50Hz), 5.0 SBCG(60Hz) / 4.0 SBEG(50Hz), 6.5 SBCG(60Hz) / 5.4 SBCG(50Hz), 8.0 SBEG(60Hz) / 6.4 SBEG(50Hz), 10.0 SBEG(60Hz) / 8.0 SBEG(50Hz), 12.5 SBEG(60Hz) / 10.0 SBEG(50Hz), 14.0 SBEG(60Hz) / 11.6 SBEG(50Hz)



23-2804
Rotor

Replaces: Westerbeke 42201
Fits: 4.5 BCG(60Hz)/3.75 BCG(50Hz), 7.0 BCG(60Hz)/5.0 BCG(50Hz), 7.0 BCGA(60Hz)/5.0 BCGA(50Hz), 9.0 BTG(60Hz)/7.0 BTG(50Hz), 6.5 BCG(60Hz)/4.8 BCG(50Hz)



18-7945C
Fuel Water Separator Filter (Chrome)

Replaces:
Mercury - 35-802893Q
Yamaha - ABB-FUELF-IL-TR



18-7824C
Oil Filter (Chrome)

Short GM
Replaces:
Chris-Craft: 16.81-08746
Crusader: 201104, Indmar: 50-1001
Mercuriser: 35-802885Q, 32716, 866340Q02, Q03, 866340K01,
Mercuriser Vazer, OMC: 173232, 502902
Pleasurecraft: R077002
Volvo-Penta: 835440
Yamaha: YSC-10231-20-0C
Thread Spec: 13/16" x 16NPT



18-7050
Carb Kit

Replaces: Honda
Fits: BF9.9(2000 & below), BF15(2002 & below)



18-7051
Carb Kit

Replaces: Honda
Fits: BF9.9(2001 & Up), BF15(2003 & Up)



18-7052
Carb Kit

Replaces: Honda
Fits: BF75(1997 & Up), BF90(1997 & Up)

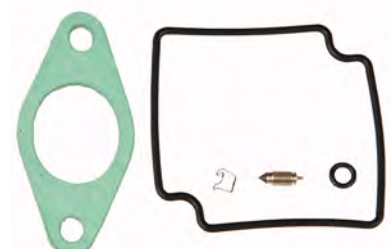

18-7053
Carb Kit

Replaces: Honda
Fits: BF75(1996 & below), BF100(1996 & below)



**18-7047
Needle Valve**

Replaces: Honda 16011-ZV4-005
Fits: BF8(2001 & Up), BF9.9(All), BF15(All), BF20(2003 & Up), BF25(All), BF30(All), BF35(1997), BF40(All), BF45(1997), BF50(All), BF75(1997 & Up), BF90(1997 & Up)



**18-7048
Needle Valve**

Replaces: Honda 16011-881-741
Fits: BF5(2003 & below), BF8(All), BF75(1997 & below), BF100(1997 & below)



**18-2480
Gasket Set**

Replaces: Honda 16010-ZV4-005
Fits: BF8(2001), BF9.9(2001 & below), BF15(2002 & below), BF25(All), BF30(All), BF35(1997), BF40(All), BF45(1997), BF50(All), BF75(1997-06), BF90(1997-06)



**18-2481
Gasket Set**

Replaces: Honda 16010-ZW9-003
Fits: BF8(2002 & Up), BF9.9(2002 & Up), BF15(2003 & Up), BF20(2003 & Up)

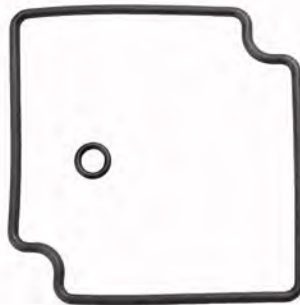

**18-2482
Gasket Set**

Replaces: Honda 16010-881-003
Fits: BF5(2003 & below), BF8(2000 & below, 2003 & Up), BF50(1996 & below), BF75(1996 & below), BF100(1996 & below)



**18-2470
Gasket, Carb Mounting**

Replaces: Honda 16221-ZV4-610
Fits: BF9.9 (2000 & below), BF15 (2002 & below)



**18-2471
Gasket, Carb Mounting**

Replaces: Honda 16221-ZW9-000
Fits: BF8(2001 & Up), BF9.9(2001 & Up)



**18-2472
Gasket, Carb Mounting**

Replaces: Honda 16221-ZW1-000
Fits: BF75(1997-06), BF90(1997-06)

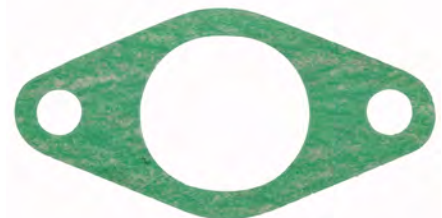

**18-2473
Gasket, Carb Mounting**

Replaces: Honda 16201-881-850
Fits: BF8(2000 & below, 2003 & Up), BF75(1996 & below), BF100(1996 & below)

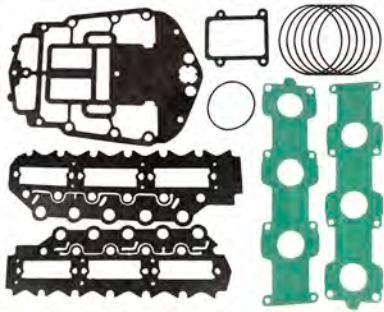

18-4420

Gasket Kit

Replaces: OMC/Bombardier 439202
Fits: 150 Ficht FFI, 175 Ficht FFI

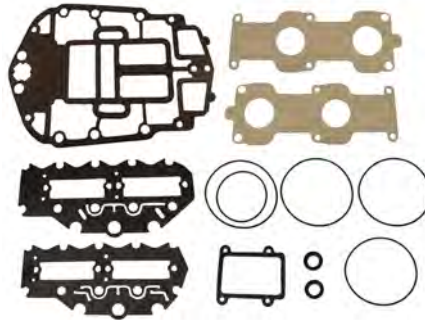

18-4421

Gasket Kit

Replaces: OMC/Bombardier 5000400
Fits: 90 Ficht FFI, 115 Ficht FFI, 135 Ficht FFI

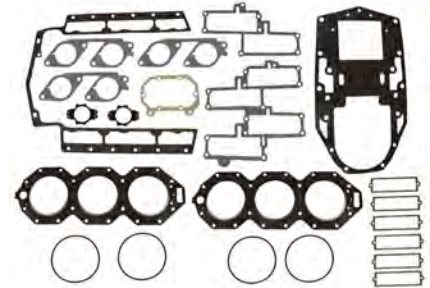

18-4428

Gasket Kit

Replaces: OMC/Bombardier 437725
Fits: 200 BB (1993 & Up), 225 BB (1993 & Up),
225 Ficht FFI (1999 & Up), 250 Carb only (2000)

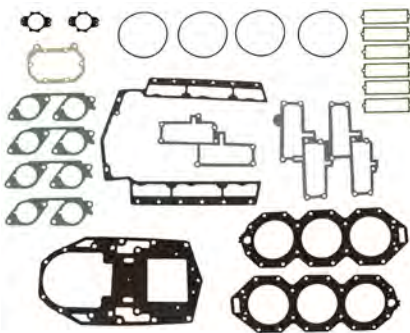

18-4429

Gasket Kit

Replaces: OMC/Bombardier
Fits: 200 Ficht FFI (1999-01), 225 (2000-04), 250
(2000-04), 3.3L (2000-04)

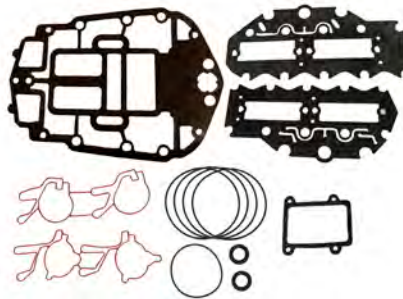

18-4402

Powerhead Gasket Kit

Replaces: OMC/Bombardier 437779
Fits: 90 V4 60 degree (1995-00), 115 V4 60
degree (1995-00)

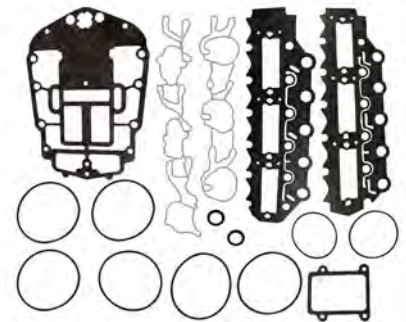

18-4406

Powerhead Gasket Kit

Replaces: OMC/Bombardier 437155
Fits: 150 60 degree (1991-00), 175 60 degree
(1991-00)



18-0690

Base Gasket

Replaces: OMC/Bombardier 347205
Fits: 200 BB (1993 & Up), 200 Ficht FFI (1999-
01), 225 BB (1993 & Up), 225 Ficht FFI (1999 &
Up), 225 (2000-04), 250 Carb only (2000), 250
(2000-04), 3.3L (2000-04)



18-0691

Base Gasket

Replaces: OMC/Bombardier
Fits: 150 Ficht FFI, 175 Ficht FFI

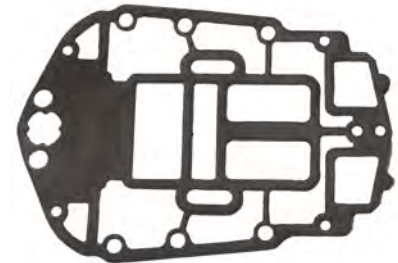

18-0692

Base Gasket

Replaces: OMC/Bombardier 339601
Fits: 90 V4 60 degree (1995-00), 90 Ficht FFI,
1150V4 60 degree (1995-00), 115 Ficht FFI,
135 Ficht FFI, 150 60 degree (1991-00), 175 60
degree (1991-00)



**18-0693
Intake Gasket**

Replaces: OMC/Bombardier 336227
Fits: 135(2005-06), 150(1991-98), 150(1991-06), 175(1991-06)



**18-0694
Intake Gasket**

Replaces: OMC/Bombardier 336226
Fits: 135(2005-06), 150(1991-05), 175(1991-05)

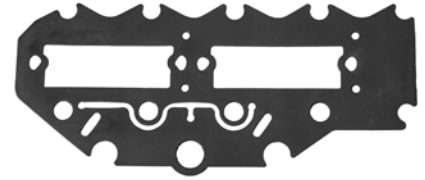

**18-0695
Intake Gasket**

Replaces: OMC/Bombardier 336389
Fits: 90(1995-06), 115(1995-06), 100(1998-01, 2005)



**18-0696
Intake Gasket**

Replaces: OMC/Bombardier 336388
Fits: 90(1995-06), 100(1998-01, 2005), 115(1995-06)



**18-0492
Head Gasket**

Replaces: OMC/Bombardier 340919
Fits: 200 BB (1993 & Up), 225 BB (1993 & Up), 225 Ficht FFI (1999 & Up) 250 Carb only (2000)



**18-0491
Head Gasket**

Replaces: OMC/Bombardier 346007
Fits: 200 Ficht FFI (1999-01), 225 (2000-04), 250 (2000-04), 3.3L (2000-04)

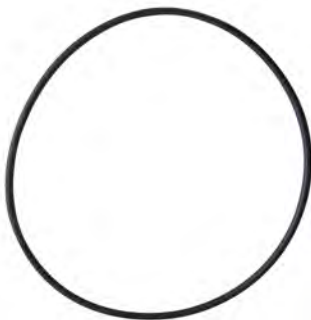

**18-0490
Head Gasket (O-Ring)**

Replaces: OMC/Bombardier 335523
Fits: 90 Ficht FFI, 115 Ficht FFI, 135 Ficht FFI, 150 Ficht FFI, 175 Ficht FFI, 90 V4 60 degree(1995-00), 115 V4 60 degree (1995-00), 150 60 degree(1991-00), 175 60 degree(1991-00)



**18-8219
Transom Seal Kit**

Replaces: Mercruiser 30-803100T1
Fits: Bravo I/II/III (1988 & Up) S/N 0B664190 & Up; Blackhawk (1994-95) S/N 0F186717 & Up
Utilizes non-servicable gimbal bearing



**18-8213
Transom Seal Kit**

Replaces: Mercruiser 30-803097T1
Fits: R, MR, Alpha 1 (1983-90) S/N 6225577-0D469858; Alpha 1 SS (1986-89) S/N 0A545004 & Up
Utilizes non-servicable gimbal bearing



18-8217

Transom Seal Kit

Replaces: Mercruiser 30-803098T1
 Fits: R, MR, Alpha 1 (1983-90) w/exhaust tube S/N 6225577-0D469858; Alpha 1 SS (1986-89) w/ exhaust tube S/N 0A545004 & Up
 Utilizes non-servicable gimbal bearing



18-8218

Transom Seal Kit

Replaces: Mercruiser 30-803099T1
 Fits: Alpha 1 Gen II (1991 & Up) S/N 0D469859 & Up. Utilizes non-servicable gimbal bearing.
 Utilizes non-servicable gimbal bearing



18-7380

Float

Replaces: Mercury 809569
 Fits: 4(2-Stroke) All, 5(2-Stroke) All



18-7381

Float

Replaces: Mercury 16253
 Fits: 75(4-Stroke) All, 90(4-Stroke) All



18-7382

Float

Replaces: Mercury 804184
 Fits: 15(4-Stroke) All, 50 (4-Stroke) All, 9.9 (4-Stroke) (323cc) All



18-7373N

Mercarb 2V Carburetor

Replaces: Mercruiser 3310-864941A01
 Fits: 2002-2004 4.3L engines (s/n OM615000-OW300012)



18-7615N

Q-jet Carburetor

Replaces: Mercruiser Model 250/255/260/5.7L (1975-1991); OMC Model 3.8L/ 4.3L/ 5.0L/ 5.7L/ 305/350& 454 (1977-1989)



18-5465

Ignition Coil

Replaces: Mercruiser 392-863704T ss 8M0054588
 Fits: 2001 and newer 4.3L, 5.0L, 5.7L & 6.2L with 555 ECM (OM300000 and up)

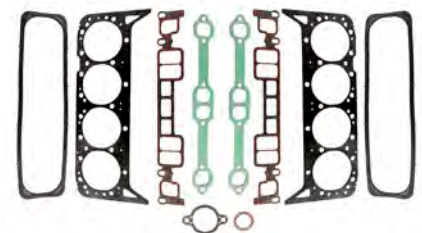

18-1254

Vortec Head Gasket Set

Replaces: Mercury Marine 27-75611A03
 Fits: Small Block GM V8 engines with Vortech heads



**18-6140
Zinc Anode**

Replaces: Universal 301068
Fits: 5424, M-30, M-35, M3-20, M3-20A, M4-30, M4-30A, M-35A



**18-6141
Zinc Anode**

Replaces: Universal 301069
Fits: 5416, M-12, M-18, M-20, M-25, M-25XP, M-25XPA, M-30, M2-12



**18-9079
Wave Washer Kit**

Replaces: Yamaha, Mercury
Fits: Yamaha 2-stroke 115-300hp (1993 & Up); Yamaha 4-stroke 115-225hp (2002 & Up); Mercury 4-stroke 225 EFI S/N 0T653945 & Up



**18-3522
Water Pump Kit w/ Housing**

Replaces: Yamaha
Fits: VZ200(2005-09), VZ225(2003-09), VZ250(2003-09), VZ300(2004-09)



**18-3523
Water Pump Kit w/ Housing**

Replaces: Yamaha
Fits: F115(2000-11), LF115(2000-11)



**18-8911
Impeller**

Replaces: Yamaha
Fits: 3(1988-02), F2.5(2003-12)



**18-79950
VST Kit**

Replaces: Yamaha
Fits: F150(04-12), LF150(04-12)



**18-79951
VST Kit**

Replaces: Yamaha
Fits: F115(00-11), F200(02-10), F225(02-06), F225TXR(07-10), LF115(00-11), LF200(02-10), LF225(02-06), LF225 TXR(07-10)



**18-79952
VST Kit**

Fits: DX150(99-05), L225(99), L250(99), LX150(99-01), LX200(99-01), LX225(00-03), LX250(00-03), PX150(99), S225(99), S250(99), SX150(99-04), SX200(00-05), SX225(00-03), SX250(00-03), V200(99), V225(99), VX150(00-04), VX200(00-05), VX225(00-04), VX250(02-04)

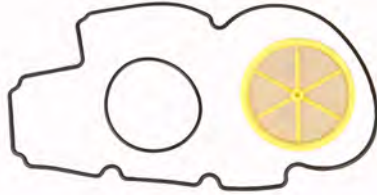

18-79953

VST Kit

Replaces: Yamaha

Fits: LZ150(00-05), LZ200(00-11), LZ250(03-05), LZ300(04-06), VZ150(00-11), VZ175(01-11), VZ200(01-09), VZ225(03-09), VZ250(03-09), VZ300(04-09), Z150(00-05), Z175(01-05), Z200(00-11), Z250(03-05), Z300(04-06)



18-79907

VST Filter

Replaces: Yamaha

Fits: Yamaha 60V-24251-01-00 Fits: LZ150(2005), VZ150(2005-10), Z150(2005), VZ175(2005-10), Z175(2005), LZ200(2005-10), VZ200(2005-09), Z200(2005-10), VZ225(2005-09), LZ250(2005), VZ250(2005-09), Z250(2005), LZ300(2005-06), VZ300(2005-09), Z300(2005-06)



18-8700

Oil Filter

Replaces: Yamaha 5GH-13440-20

Fits: F15(2006-12), F20(2006-12), F25(2009-12), F40(2008-12), F50(2005-12), F60(2005*-12), F70(2010-12), T25(2009-12), T50(2005-12), T60(2005-12)



18-8950

Impeller

Replaces: Yanmar 12423-42092

Fits: 2GM20F, 2GMF, 2QM, 2QM20, 3GM30F, 3GMF, 3HM, 3HM35, 3HM35F, 3HMF, 3QM30, 3QM30F



18-8951

Impeller

Replaces: Yanmar 128176-42071

Fits: 1GM, 1GM10

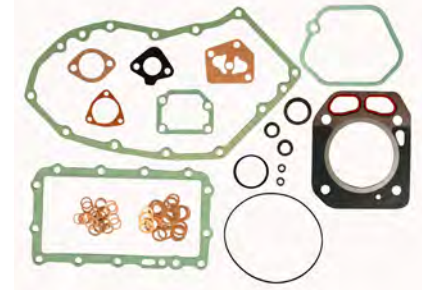

18-55500

Powerhead Gasket Set

Replaces: Yanmar 728170-92600

Fits: 1GM (7hp)

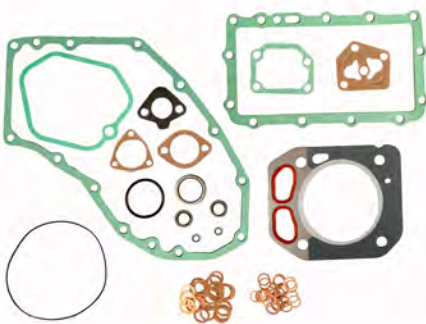

18-55501

Powerhead Gasket Set

Replaces: Yanmar 18-55501

Fits: 1GM10 (9hp)

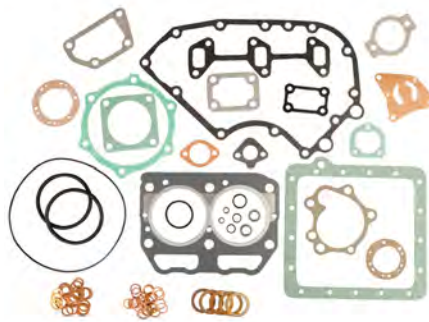

18-55502

Powerhead Gasket Set

Replaces: Yanmar 728271-92605

Fits: 2GM20 (18hp), 2GM20B, 2GM20C, 2GM20F (18hp)

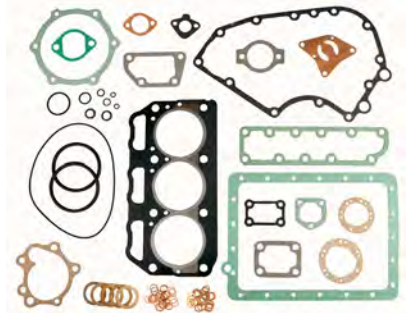

18-55503

Powerhead Gasket Set

Replaces: Yanmar 728374-92605

Fits: 3GM30 (27hp), 3GM30 EU (27hp), 3GM30F (27hp), 3GM30F EU (27hp)



18-56000

Bonnet Cover Gasket

Replaces: Yanmar 128170-11310
Fits: 1GM, 1GM10



18-56601

Thermostat Gasket

Replaces: 104211-49160
Fits: 1GM, 1GM10

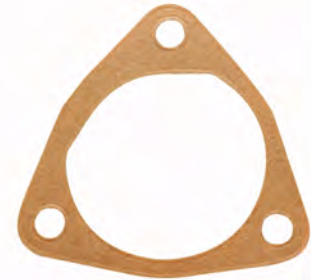

18-56602

Water Pump Gasket

Replaces: 128170-42090
Fits: 1GM, 1GM10



18-55600

Head Gasket

Replaces: Yanmar 128170-01331
Fits: 1GM (7hp)



18-55601

Head Gasket

Replaces: Yanmar 128171-01911
Fits: 1GM10 (9hp)



18-55602

Head Gasket

Replaces: Yanmar 128271-01911
Fits: 2GM20 (18hp), 2GM20B, 2GM20C, 2GM20F (18hp)



18-55603

Head Gasket

Replaces: Yanmar 128374-01911
Fits: 3GM30 (27hp), 3GM30 EU (27hp), 3GM30F (27hp), 3GM30F EU (27hp)

**Green Product
Certified
Biodegradable
Non-Staining**



18-9180

Liquifix

Degreaser 16oz.

18-9181

Liquifix

Degreaser 1 Gal.

**Green Product
Certified
Biodegradable
Non-Staining**



18-9182

Liquifix

LQ-5 Filtered Lubricant 8.5 oz

18-9183

Liquifix

LQ-5 Filtered Lubricant 16 oz

Safe-Skeg

Whether you are looking to protect your new skeg, repair your damaged one or even just add some shine. Safe-Skeg is made of 316 Marine Grade Stainless Steel Construction and installation takes minutes.

- ◆ Material Thickness: 1.5mm, 50% thicker than the competition.
- ◆ Drain Hole to protect against corrosion and freeze-up.
- ◆ Brilliantly polished with seamless design.
- ◆ Skid Plate not necessary due to extra thickness in material.



NEW PRODUCT - 2013

Motor	Horsepower	Stroke	Year Range	Part #
Evinrude/Johnson	150-175-185-200-225	2	1986-2003	35-SS630
Evinrude/Johnson	90-100-115-120-140	2	1980-2001	35-SS635
Force Outboard	70 - 90 HP (by Mercury)	2	1998-2002	35-SS625
Force Outboard	70-75	2	1991-1997	35-SS650
Mercruiser	Pre Alpha #1 Drives		1973-1984	35-SS600
Mercruiser	Alpha 1 Drives		1985-1990	35-SS605
Mercruiser	Alpha 1 Generation II Drives		1991-Present	35-SS610
Mercruiser	Bravo 1 & 3 Drives		1990-Present	35-SS615
Mercury/Mariner	225	2	1996-2004	35-SS660
Mercury/Mariner	135-150-175-200	2 & 4	1978-2005	35-SS620
Suzuki Outboard	150-175-200-225	2	1986-2002	35-SS645
Volvo Penta	SX Drives (Single Prop)		1995-2006	35-SS665
Yamaha Outboard	200-225-250-300	2 & 4	2003-Present	35-SS695
Yamaha Outboard	60-70-80-90-100	2 & 4	2002-Present	35-SS700
Replacement Hardware Installation Kit				35-SSKIT1

SERVICE SHOP KITS

Sierra is unique among manufacturers with its Service Shop Program. We're here to support the dealers by offering six new kits featuring the fastest moving parts by OEM. All these products are covered by our industry leading warranty. Sierra helps you benefit from a personalized service package designed to stimulate your sales and help reach your goals. Just work with your distributor to order the right kit for your business, so they're ready when you need them. After you use a part, just reorder and restock. It's that simple.



FEATURES

- ◆ Small investment for a large return.
- ◆ Sierra Super Kits allow you to increase the number of engine brands you service.
- ◆ By carrying our Super Kits for the engine brands you do not carry you will increase your service capacity, response time and add additional profits.
- ◆ You will offer an industry leading warranty from the leading aftermarket marine parts supplier in the United States and 54 other countries.
- ◆ Limited lifetime warranty on parts and labor on Sierra products plus we even pay for incidentals like towing and haul out.
- ◆ You can bolt on any Sierra product while an engine is still under warranty and you will not void the engine manufacturer's warranty.
- ◆ Increase service time, increase profits, decrease response time, and the best warranty in the business period.

KITS	PART NO.	DESCRIPTION
VOLVO	VOLVASSORT	Volvo Service Shop Assortment
EVINRUDE JOHNSON	JOHNASSORT	Johnson/Evinrude Service Shop Assortment
MERCURY OUTBOARD	MERUASSORT	Mercury Service Shop Assortment
MERCUISER	MCRUASSORT	Mercruiser Service Shop Assortment
SUZUKI	SUZUASSORT	Suzuki Service Shop Assortment
YAMAHA	YAMAASSORT	Yamaha Service Shop Assortment

GENERATOR PARTS

Sierra International is pleased to announce over 100 products focused entirely on servicing the marine generator market. Recognizing the lack of available aftermarket generator service parts, this market segment represents an entirely new product line for Sierra.

Utilizing our famed catalog design and easy to use reference charts, finding the generator part you need when you need it will be easier than ever before. The following pages cover all applicable product categories (Electrical, Fuel, Cooling, Internal Engine, Gaskets, & Corrosion Protection); with a focus on Kohler®, Onan® & Westerbeke® Generator Sets.

Like all Sierra products, quality is insured by our industry leading Limited Lifetime Warranty. This warranty covers you in the unlikely event of a product failure with not only defective product replacement, but the labor and incidental charges reimbursed as well.

Aftermarket generator service parts, another first from Sierra!

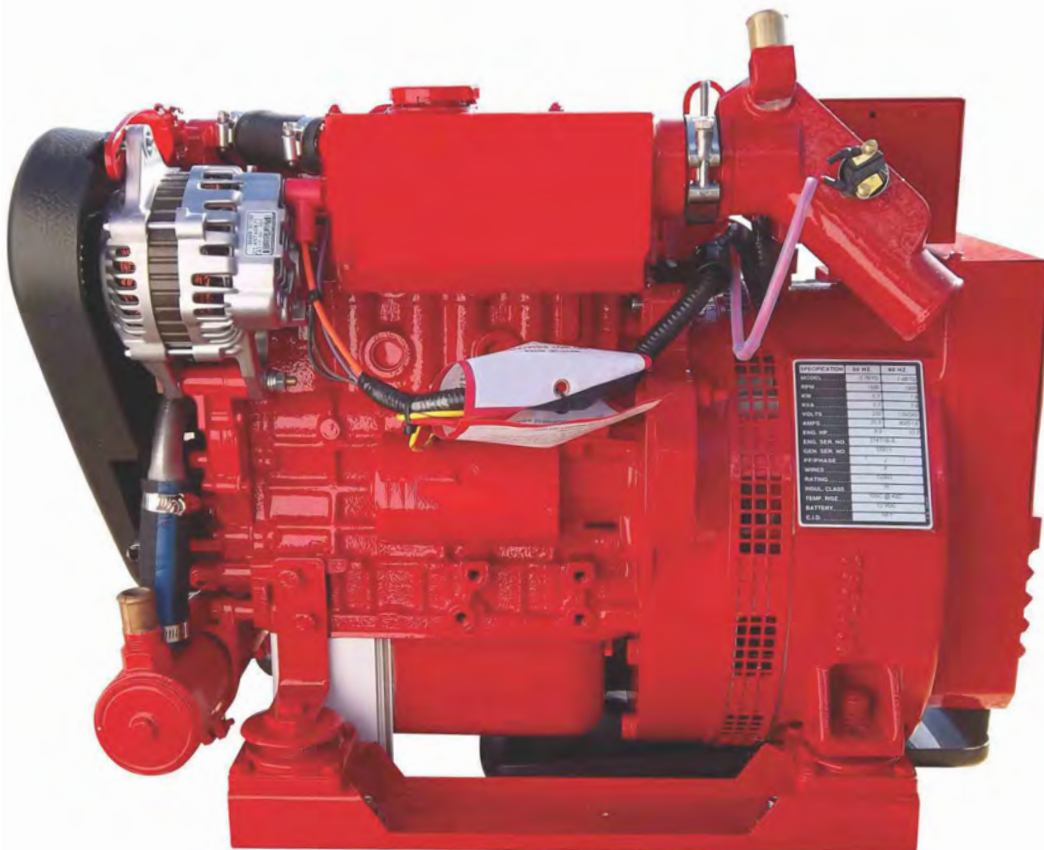

**WE NOW SUPPLY THE PARTS THAT
GENERATE THE POWER!**

OIL & LUBRICANTS

All oil is not created equal, and it's vital to recognize and understand the differences. Sierra NMMA certified marine engine oils have been developed to meet the specific lubrication needs of marine engines operating under unique and challenging environmental conditions.

This includes the development of specialized additives designed to inhibit corrosion and moisture and protect engine surfaces in a watery world.

Sierra oil and lubricants are blended to the same high standards as the OEM oils and meet the same FC-W and TC-W3 certification standards. Sierra offers specific oils for your brand of engine, not a "one size fits all" product.

Sierra offers the widest variety of oils on the market to match your engine's needs including:

- ◆ Gasoline - Inboard Sterndrive Engine Oil
 - 25W-40 Premium Blend
 - 25W-40 Synthetic Blend
 - 10W-30 Full Synthetic Blend
 - SAE 30 Full Synthetic Blend
- ◆ Gasoline - Outboard Engine Oil - FC-W
 - 10W-30 Premium Blend
 - 10W-30 Full Synthetic Blend
 - 10W-40 Semi-Synthetic Blend
 - 25W-40 Synthetic Blend
 - 25W-50 Synthetic Blend
- ◆ Diesel - Inboard Sterndrive Engine Oil
 - 15W-40 Diesel
- ◆ Gasoline - Outboard Engine Oil - TC-W3
 - Premium 2-Cycle Blend
 - Direct Injection Synthetic Blend
 - Full Synthetic 2-Cycle Blend
- ◆ Gear Lubricants
 - Premium Blend
 - Hi-Performance Synthetic Blend
 - Full Synthetic Blend
 - Type C, Electric Shift



DISPLAYS

Display comes complete with:

- Corrugated display with high impact graphics
- One case of quart bottles
- One case of gallon bottles
- Installation instructions

18-9494	TC-W3 DISPLAY ONLY
18-9495	OUTBOARD OIL DISPLAY ONLY
18-9496	FULL SYNTHETIC TC-W3
18-9497	10W-40 FC-W SEMI SYNTHETIC
18-9498	10W-30 OUTBOARD 4-CYCLE OIL DISPLAY
18-9499	PREMIUM TC-W3 OIL DISPLAY



FUEL SOLUTIONS

Today's marine engines work in a demanding environment. Increased levels of sophistication coupled with ethanol fuel blends necessitate the use of a high quality fuel filter. Engineered for today's sterndrive and inboard engines along with 2-cycle and 4-cycle outboard high and low pressure fuel systems. Sierra filters are engineered to offer the ultimate in filtration, separation of water from the fuel supply and provide maximum fuel flow. Sierra filters are the best in the business.

FACTS ON ETHANOL AND 99% WATER SEPARATION

Water is commonly found in fuel systems and can come from a variety of sources. Condensation, fuel handling and humid marine environments will increase the presence of water. Water contaminated fuel can lead to poor engine performance and even engine damage. Today's ethanol blended fuels can increase the chance of water in the fuel tank. Fuel provides lubrication to the fuel injection system. Any water that displaces the fuel's lubricating qualities can increase the chances of premature wear and component damage. That's why it's so important to use Sierra's high efficiency water separating filter with Sierra's new ethanol fuel treatment.

FACTS ABOUT FUEL FLOW

Sierra's 10 micron filters flow over 90 GPH. Constant fuel flow to the injectors must be guaranteed, regardless of how choppy the water can get or how tight the turn. Minimizing resistance to flow ensures that the engine is never starved of fuel. Poor fuel flow through a filter deprives engines of their vital needs, causing them to work harder, lose power and create rapid engine wear over shorter periods.

SIERRA'S 10 MICRON FILTERS

Sierra's 7900 series 10 micron filters eliminate harmful 10 micron and larger sized contaminants at over 90% efficiency, while removing over 99% of emulsified water. Don't settle for less, demand the best! Demand Sierra filters and enjoy years of lasting performance.

WHY 10 MICRON FILTRATION @ OVER 90% EFFICIENCY?

Once in the fuel injection system, 10 micron contaminants and larger can cause severe damage because of the close tolerances within fuel pumps and injectors. Clogged injectors and/or worn fuel pumps causes inadequate fuel delivery that can lead to poor fuel economy and engine performance.

Sierra's 10 Micron Fuel Water Separation Filter Performance Test Over 90% Filtration Efficiency at 10 Micron

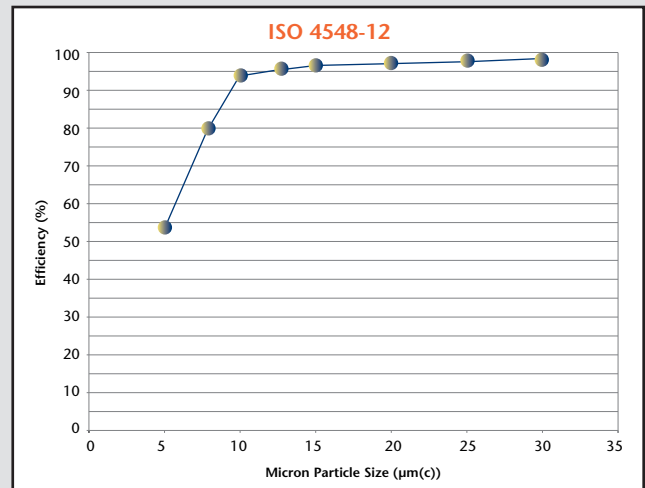

Particle Removal Efficiency vs. Particle Size
Test after Test after Test...



SILVERADO 4000

No discussion of Sierra/Shields would be complete without mentioning their best feature, uncompromising quality backed by the marine industries leading warranty. No other competitor can offer reimbursement for parts, labor (at posted shop labor rate), and pay for incidental (collateral) damage. With quality products come a quality customer satisfaction warranty.

Many fuel related products (fuel feed hose, primer bulbs and fuel line assemblies) are required to meet multiple standards. The two most important include the EPA (Environmental Protection Agency) which concerns itself with the environmental impact of utilizing certain products and the SAE (Society of Automotive Engineers) which concerns itself with safety concerns.

What do you get when you combine the best B1 fuel line and primer bulb in the market? None other than Sierra's Silverado 4000 fuel line assemblies. With unequaled performance, easy of installation, and updated packaging, the Silverado 4000 fuel line assemblies have become an industry sensation.



New Retail Packaging



Focus Product - Fuel Solutions

Part Number	Description	OEM	OEM Part No.
18-8011EP-1	Fuel Line Assembly	Chrysler/Force	FS409752
18-81042EP-1	Fuel Line Assembly	Honda	17700-ZW9-010, 17700-ZW9-020
18-8009EP-1	Fuel Line Assembly	Johnson/Evinrude	398549
18-8014EP-1	Fuel Line Assembly	Johnson/Evinrude	174509
18-8010EP-1	Fuel Line Assembly	Mercury	
18-8012EP-1	Fuel Line Assembly	Mercury	32-858114Q08, 32-858114K08
18-8024EP-1	Fuel Line Assembly	Mercury	32-858104Q08, 32-858104K08
18-8025EP-1	Fuel Line Assembly	Mercury	32-858105Q08, 32-858105K08
18-8016EP-1	Fuel Line Assembly	Mercury	32-858109Q12, 32-858109K12
18-8023EP-1	Fuel Line Assembly	Mercury	32-857103Q12, 32-857103K12
18-8027EP-1	Fuel Line Assembly	Nissan/Tohatsu	
18-8018EP-1	Fuel Line Assembly	Suzuki	65700-95513
18-8019EP-1	Fuel Line Assembly	Suzuki	
18-8035EP-1	Fuel Line Assembly	Suzuki	65700-87J10
18-8017EP-1	Fuel Line Assembly	Yamaha	6YL-24306-60-00
18-8013EP-1	Fuel Line Assembly	Universal	N/A
18-8015EP-1	Fuel Line Assembly	Universal	N/A
18-8032EP-1	Fuel Line Assembly	Universal	N/A
16-337-0560	5/16" Silverado 4000 Bulk	N/A	N/A
16-337-0563	5/16" Silverado 4000 10' Polypac	N/A	N/A
16-337-0565	5/16" Silverado 4000 25' R/O Carton	N/A	N/A
16-337-0566	5/16" Silverado 4000 50' R/O Carton	N/A	N/A
16-337-0380	3/8" Silverado 4000 Bulk	N/A	N/A
16-337-0383	3/8" Silverado 4000 10' Polypac	N/A	N/A
16-337-0385	3/8" Silverado 4000 25' R/O Carton	N/A	N/A
16-337-0386	3/8" Silverado 4000 50' R/O Carton	N/A	N/A

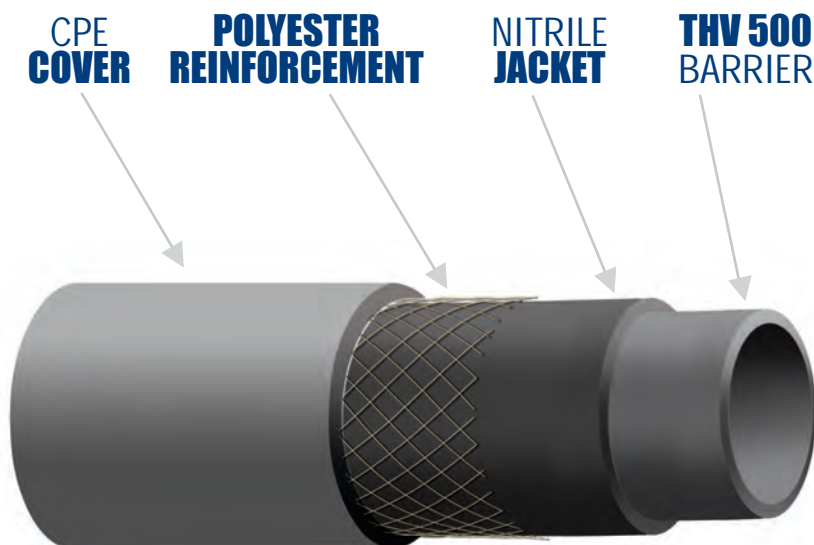

CONSTRUCTION

The series 337 fuel lines (Silverado 4000) is the best B1 fuel line in the market place. Utilizing a complex construction technique involving a THV500 barrier layer, a Nitrile jacket, Polyester reinforcement and a CPE cover; we are able to offer a hose that outperforms all competitors. The Silverado 4000 hose has a small O.D., is extremely flexible and easy to clamp. Not only does the Silverado 4000 meet all requirements it has become the only fuel line worthy to be utilized in Sierra's fuel line assemblies.

CARBURETORS

Introducing New Carburetors from Sierra International

- ◆ Completely new (not remanufactured) carburetors cast and tooled utilizing Sierra's own proprietary tooling.
- ◆ Available in popular "Mercarb" two barrel (2V) version (18-7373N) and "Rochester Q-Jet" four barrel (4V) version (18-7615N). Covers most popular applications with other variations to be introduced next model year.
- ◆ First all new replacement "Q-Jet" available since the 80's. Most popular 4V carburetor utilized by all sterndrive/ inboard manufactures with millions produced since the early 70's.
- ◆ Manufactured from corrosion resistant aluminum with anodized components for years of trouble-free operation.
- ◆ No core charge.
- ◆ Covered under Sierra's industry leading warranty.
- ◆ Enhances performance and economy by bringing carburetor back to "as delivered" condition.

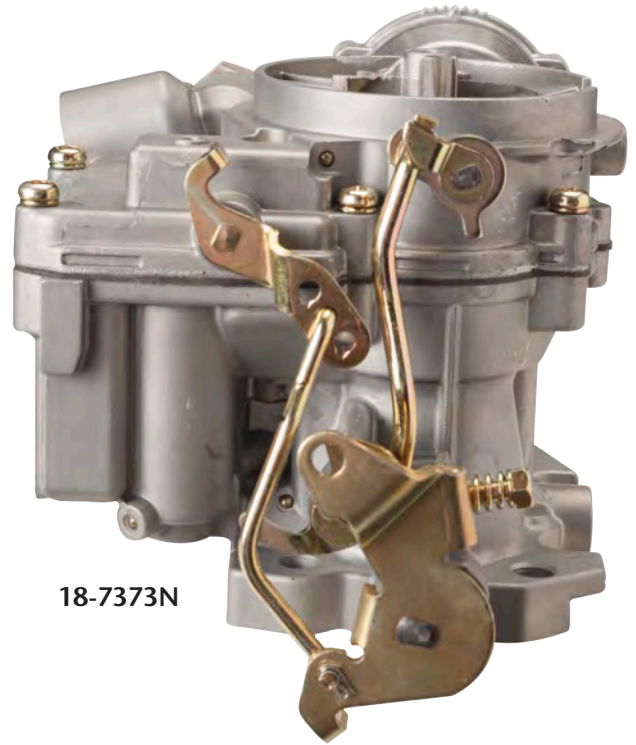

18-7373N

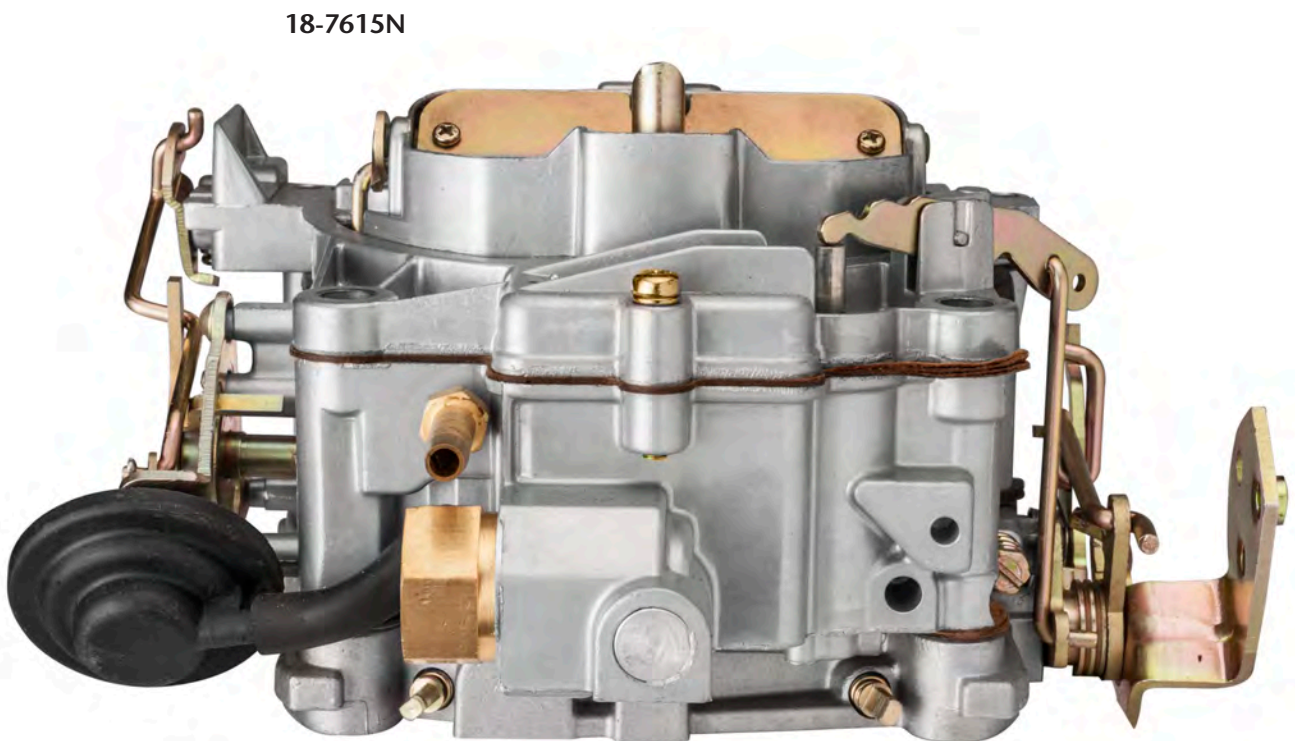

18-7615N

DRIVE SYSTEMS

You just can't beg, borrow, or steal a line of drive components offering better precision, better quality or better reliability anywhere. Advanced engineering and manufacturing technology goes into every single part we produce. Through years of testing and development, we have produced a very successful drive program that no competitor can match.

These units and their components are engineered to OEM specification and are fully interchangeable with their OEM counterparts. At Sierra, we've gone to extreme measures to assure the quality and reliability of our new complete upper and lower drive units. In fact, the production is inspected by personnel with an average of 20 years experience in sterndrive repair and assembly. Every unit is pressure checked and vacuum tested for quality assurance.

HIGH STANDARDS

- ◆ Meets over 300 hours of rigorous on the water testing.
- ◆ Every unit is assembled following stringent quality control procedures.
- ◆ Die cast gear housings provide high impact and structural tensile strength to meet high load demands.
- ◆ Baked enamel paint process provides durable long lasting finish.
- ◆ CNC machined housings for precise tolerances and exact centerlines.

DRIVE SHAFT

These precision bi-metal components are made using state-of-the-art techniques. 8620 bearing quality steel and 17-4 PH stainless steel are joined together using an inertia/friction welding process. These shafts withstand stresses that result from combinations of torsion, bending, and shock loading.

- ◆ Less than .001 T.I.R. (Total Indicated Run-out).
- ◆ Machined from certified steels.
- ◆ Rockwell hardened, ground, and micro polishing create bearing race quality surfaces.
- ◆ Involute splines used for all shafts and gears.



18-2186

SHIFT CABLES SIERRA EXCLUSIVE

This cable is manufactured using the Teleflex patented **TFXTREME** core technology. By utilizing this technology, we have been able to not only improve upon the OE design, but offer an exclusive product only available from Sierra.

- ◆ Reduced cable friction for smoother shift operation and longer life.
- ◆ Minimal lost motion for precise shifting with positive feedback.
- ◆ Super tough HPDE jacket for ultimate protection against the elements.
- ◆ Self lubricating long wearing HPDE inner liner eliminates friction.
- ◆ Unique splined core allows for close tolerance with less contact surface.
- ◆ Lower unit shift cables for MerCruiser 1, R, MR, Gen II, and Bravo applications (18-2190E & 18-2145E)

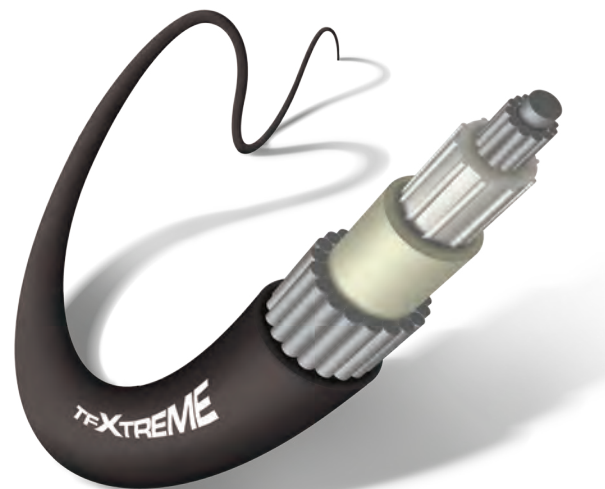

ALL THE PARTS. ALL THE TOOLS. ALL THE QUALITY.

GEAR SETS

Sierra invested more than three years in development and testing our current line of gear sets that included all new forging dies, developing stringent material and heat treat specifications. Our gear sets are fully compatible with their OEM counterparts, this means you can run our gears with OEM gears accordingly. They shim the same, install the same, mesh the same, and last as long or longer.

LOWER GEAR SETS

- ◆ Located in the lower unit, these spiral bevel gears transfer the power from the vertical driveshaft to the horizontal prop shaft.
- ◆ Our gear machining process for MerCruiser gear sets is very similar to the OE and dimensionally exact.
- ◆ Our gears are cut from tempered forgings, a higher quality product is produced using forged steel verses bar stock steel.
- ◆ Forgings are stamped from certified 8620 and 9310 aircraft quality steel.
- ◆ Heat treat specifications are batch certified
- ◆ Gear configurations verified by CMM (Coordinate Measuring Machine) technology.

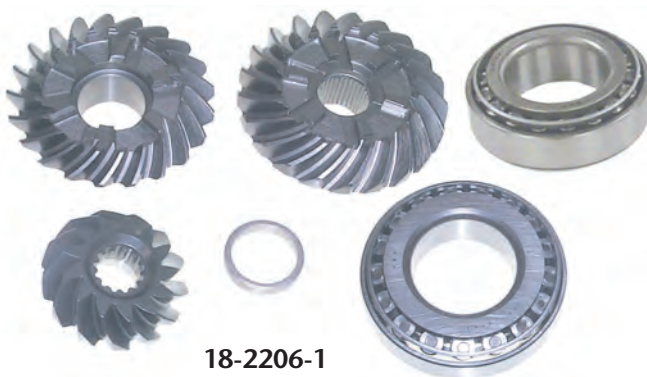

UPPER GEAR SETS

- ◆ Sierra's upper drive gears for MerCruiser are machined from forged blanks to OEM's latest design specifications.
- ◆ Drive ratio must be determined for proper application 1.5:1 (V-8), 1.65:1 (I-6), 1.84:1 (V-6 & Model 470 I-4), 1.98:1 (I-4).
- ◆ Available as gear sets or upper unit rebuild kits.
- ◆ All kits complete with required bearings, o-rings, shims, seals, and gaskets.



DID YOU KNOW:

Sierra's drive kits supply you with all needed components to complete the job.

GIMBAL BEARINGS

There are many inexpensive bearings on the market today. Sure they may look the same and have the same reference numbers or markings, but how tight are the tolerances in manufacturing? What grades of materials are being used?

- ◆ Precision ground alignable ball bearings of deep groove construction with larger balls and thicker rings for high capacity and longer life.
- ◆ Micro polished races eliminate bearing noise.
- ◆ Extra inner ring width furnishes ultimate shaft and load support and concentricity for high speed precision applications.
- ◆ Manufactured by an OEM supplier.
- ◆ Sealed SKF Versions for Mercruiser & Volvo available complete with allen head screw to plug grease passage.



ALL THE PARTS

Our Drive Program gives you drive parts from prop nuts to housings. We offer components, rebuild kits and even lubricants for outboards, Alpha, Alpha Gen II, "R" style, "MR" style, Bravo, Cobra and Stringer sterndrives. You can actually build a complete drive from scratch with premium quality precision parts from Sierra.

ALL THE TOOLS

Sierra has the tools and manuals you need to get the jobs and repair them perfectly. All the tools. From the drive shaft preload tool to needle bearing drivers. All precision manufactured so you can work fast, accurately, and efficiently. And all Sierra tools, like all Sierra parts, are covered by Sierra's industry leading warranty.

POWER TRIM CYLINDER

These new trim cylinders give Sierra the competitive edge in quality and coverage. They have endured extensive testing in salt water, abusive impact shock testing, and extensive cycle testing to assure they will exceed your expectations.

- ◆ Long lasting high gloss finish.
- ◆ Excellent corrosion resistance.
- ◆ Extensive testing for safety and durability.
- ◆ Marine grade stainless steel shaft.
- ◆ Manufactured by hydraulic experts.



18-2142

BELLOWS

- ◆ Bellows protect the driveshaft and shift cable from the elements and provides a seal. The exhaust bellows route the engines exhaust through the outdrive unit.
- ◆ Components are measured using state of the art optical dimensioning equipment.
- ◆ Materials are selected to withstand environmental conditions to ensure long life.
- ◆ All bellow kits are packaged with marine grade stainless steel clamps.



18-2751



18-2750

ALL THE QUALITY

Every drive part and every drive tool meets or exceeds original specifications. Every component equals or outlasts the part it replaces. Fit is perfect. Form is unchanged. Function is actually improved in many instances. Installation and shimming specifications duplicate exact OEM characteristics.

**SIERRA
EXCLUSIVE**

**18-7634
OMC COBRA DRIVE
TRIM SENDER**



**18-21755
COUPLER**

Fits: OMC 2.3L Ford



**18-21754
COUPLER**

Fits: 460 King Cobra



COOLING SYSTEM

Our cooling system parts are a perfect example of dedication. Often overlooked and neglected, the cooling system is vital to the life of any engine. From the smallest outboard to the largest cruisers, you can trust Sierra to provide the best performing parts. We have invested hundreds of thousands of dollars in tooling and engineering to develop our impellers, water pumps, water pump kits, thermostat housings, and manifolds. Sierra cooling system parts offer time saving conveniences and feature innovative engineering that extends the life of your engine and makes boating more enjoyable.

WATER PUMP KIT

Our kits are available in a number of variations to give you the flexibility of repair. We offer impellers, wear plates, water pump bases, upper housing kits, lower housing kits, complete kits and the list goes on. Complete kits contain all of the parts necessary to do the job right.

- ◆ All impellers are made from 100% virgin nitril or neoprene rubber compounds.
- ◆ Durometer constantly monitored for consistent quality.
- ◆ Hub inserts match OEM materials and specifications.
- ◆ Extensive inspection and testing on each impeller batch insures proper bonding and performance.



18-3150

THERMOSTAT KIT

Not all thermostat kits are created equal. Genuine Sierra thermostat kits are engineered to work in harsh and corrosive marine environments.

- ◆ All kits feature high-grade stainless and brass bi-metal thermostats.
- ◆ Correct operating ranges for proper cooling performance.
- ◆ Kits come with all necessary components to complete the job.



18-3611

WATER PUMPS

The water pump is the heart of all cooling systems. There are three basic pump types:

- ◆ Lower unit mounted pickup pump (Outboard and I/O applications).
- ◆ Engine mounted/engine driven pickup pump (I/O & Inboard applications).
- ◆ Engine Circulating pump (I/O & Inboard applications).



18-3587

MANIFOLDS & ELBOWS

Sierra sets the quality standard with our full line of manifolds and risers. We own the tooling on all fast moving manifolds. Owning your own tooling, scheduled and preventative maintenance and monitoring tool wear ensures minimal to zero porosity, proper configuration and uniform wall thickness, just to name a few. With Sierra, you order it, install it, and forget it.

- ◆ Ready to install right out of the box.
- ◆ Packaged as kits with all necessary hardware to complete the job including all the necessary hardware and gaskets.
- ◆ E-coat finishing process ensures maximum coating adhesion for superior corrosion protection.
- ◆ Most manifolds feature semi-tuned runners for maximum performance.
- ◆ Cast from SAE G 3000 grey-iron from the leading foundries.

18-1848



CIRCULATING WATER PUMP

Sierra builds the best engine circulating pumps in the business. No other competitor can match the quality and service from genuine Sierra pumps.

- ◆ All new components, new pump housing castings, not rebuilt units.
- ◆ Brass bi-directional impeller for proper flow in both directions and ultimate corrosion protection.
- ◆ Long lasting "true" carbon resin seal rather than the automotive style ceramic seal used by competitors.
- ◆ Housings are powder coated for greater durability and corrosion protection.
- ◆ Pulley mounting hub is machined not stamped, providing less than .002 TIR (Total Indicated Run-Out).
- ◆ Stainless steel backing plate and corrosion resistive attaching hardware.
- ◆ 100% vacuum tested to assure no leaks.

DID YOU KNOW?

Teleflex Marine offers expert Customer and Technical Support when you need it. Contact us at 800-648-3976. You can also get support online at www.teleflexmarine.com.

18-3593

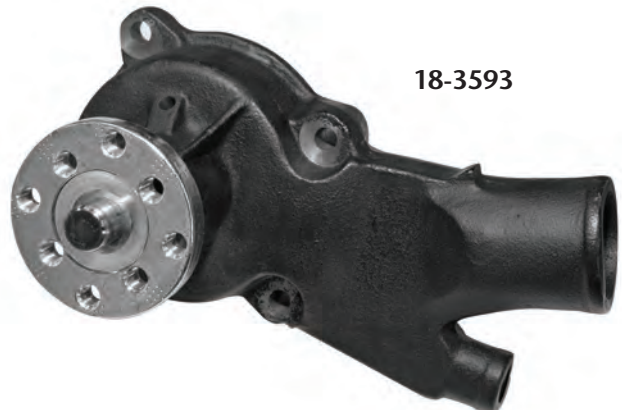

STARTERS AND ALTERNATORS

Ignition and Electrical products are where Sierra's quality really stands out from the competition. We bypass OEM patents on ignition products by upgrading circuitry and using grade one components. Our parts look like OE, fit like OE, and perform like OE. No splicing and no special adapters are required to make our parts work for your application.

All marine starters and alternators must be ignition-protected to reduce the possibility of explosion onboard. All Sierra starters and alternators meet UL standards for sterndrive and inboard applications. They also comply with international CE standards required by the European Economic Community. Most popular applications are available in either new or remanufactured units to provide the flexibility to meet any customers needs.

SIERRA STARTERS

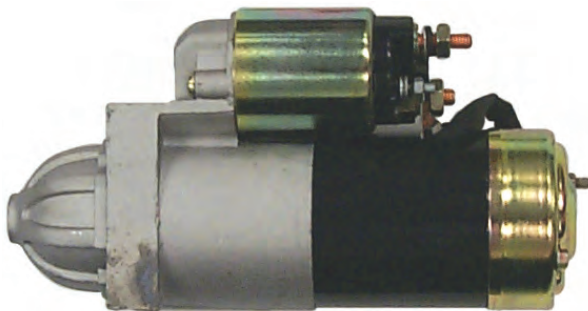

18-5913

SIERRA ALTERNATORS

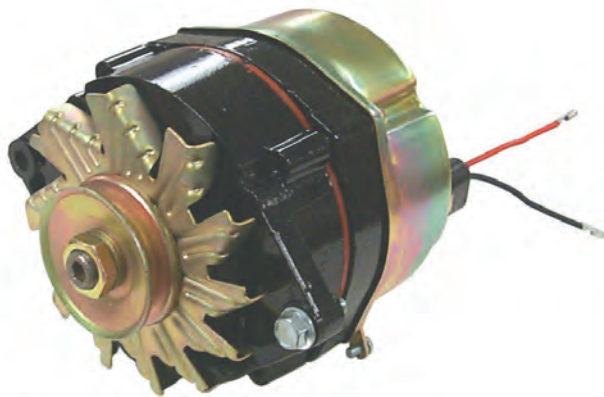

18-5951

FEATURES

- ◆ Most complete coverage for both outboard and sterndrive applications.
- ◆ 100% load tested for assured reliability.
- ◆ Powder coated housings and anodized hardware used on remanufactured units for maximum corrosion protection.
- ◆ All units meet or exceed USCG safety requirements.
- ◆ Higher output upgrades available for most popular applications to help support added electronic accessories.



HOT MOVERS

Sierra offers a complete range of starters and alternators for various applications. See our full line catalog for a complete listing.

Part No.	Description	OE	Arco #
18-5612	Outboard Starter	OMC	5391
18-5613	Outboard Starter	Chrysler Force	5393
18-5619	Outboard Starter	OMC	5387
18-5629	Outboard Starter	OMC	5376
18-5634	Outboard Starter	OMC	5372
18-5635	Outboard Starter	OMC	5370
18-5697	Brush & Spring Kit	Chrysler Force, OMC	BK900
18-5907	Starter	Crusader, Pleasurecraft, OMC	30456
18-5908	Starter	Crusader, Pleasurecraft, OMC	30457
18-5910	Starter	OMC	30450
18-5911	Starter	Chris-Craft, OMC, Volvo	30460
18-5913	Starter	OMC, Volvo	—
18-5919	Starter	OMC, Volvo	—
18-5920	Starter	Pleasurecraft, OMC, Volvo	70125
18-5951	Alternator	Pleasurecraft, OMC, Volvo	20104
18-5957	Alternator	Pleasurecraft, OMC, Volvo	60050
18-6275	Starter	Mercury, Volvo	30470

GPS SPEEDOMETERS

These GPS speedometers provide accurate speed over ground readings and heading information all in one attractive package. Available in various speed ranges to meet your application, the GPS speedometer is offered in a number of popular styles to match the colors in your boat like Premier Pro, White Premier Pro, Amega, Arctic and Eclipse instrument lines. Use our GPS antenna (connectors included) or connect to an existing NEMA 0183 GPS device.



781-684-080P

ACCESSORIES



56967P
Hourmeter
Rectangular

BLACK STERLING

With its rich luster and polish, Black Sterling instruments convey a look of utmost sophistication and add elegance to any dash. These instruments have fire-orange pointer tips and stainless graphics for a contemporary, ultra stylish look. Black Sterling instruments have clean, crisp black dials which highlight the stainless accents.



69073P



56966P
Hourmeter
Round

LIDO FOG RESISTANT

Now available with fog resistant lens perfect for offshore fishing boats. Hottest selling white dial line! A comprehensive family of instruments for most engine types, Lido features crisp white dials and fire-orange pointer tips. Red through-dial and white perimeter lighting provide great night readability. Excellent inboard coverage with engine sync gauges* and diesel alternator and magnetic pickup tachometers**.

*Module required, not included with gauge.
**Magnetic Pickup sender available separately.



65129P



59667P
Pack O'Pitots
Package of 12



LIQUID LEVEL SENDERS

Tomorrow's fuel sender for today's tanks. Field adjustable by cutting to length. Solid state no moving parts. Gas and diesel versions.

90424P
Fuel Sender
4-24" Tank depth
Traditional swing arm design



DETWILER



JACKPLATES

The D3000 series jack plate comes in 4, 6, and 8 inch setbacks to help you find the best match for your boat and optimize performance.

The D2000 series jack plate comes in 6, 8, and 10 inch setbacks to help you find the best match for your boat and optimize performance.

The D1000 series jack plate comes in 4, 6, 8, & 10 inch setbacks to help you find the best match for your boat and optimize performance.

FEATURES

- ◆ Standard BIA mounting pattern for simplified installation.
- ◆ 300 horsepower capacity to handle the most demanding outboard engines.
- ◆ Aircraft grade 6061-T6 aluminum alloy provides high tensile strength and corrosion resistance.
- ◆ Machined from extruded billet and is work hardened for increased strength
- ◆ Mil-Spec anodize surface treatment for enhanced corrosion resistance and increased life for saltwater applications
- ◆ Stainless Steel hardware for corrosion resistance.
- ◆ Assembled in the USA to support the american economy.

D3000 (Hydraulic)

PART NO.	LEGACY NO.	MODEL	DESCRIPTION
JP3040R	OBD400A	4" Rocker Switch	4" setback with toggle switch
JP3060R	OBD600A	6" Rocker Switch	6" setback with toggle switch
JP3080R	OBD800A	8" Rocker Switch	8" setback with toggle switch
JP3060T	OGT600A	6" ProTrim	6" setback with gauge & turn signal
JP3080T	OGT800A	8" Pro Trim	8" setback with gauge & turn signal
JP3060X	OEZ600A	6" Ex-zact Dial	6" setback with ex-zact dial
JP3080X	OEZ800A	8" Ex-zact Dial	8" setback with ex-zact dial

D2000 (On The Water)

PART NO.	LEGACY NO.	MODEL	DESCRIPTION
JP2060	600M	6" Setback	6" setback jack plate
JP2080	800M	8" Setback	8" setback jack plate
JP2100	1000M	10" Setback	10" setback jack plate

D1000 (Side Locked)

PART NO.	LEGACY NO.	MODEL	DESCRIPTION
JP1040	400SS	4" Setback	6" setback with side stiffeners
JP1060	600SS	6" Setback	8" setback with side stiffeners
JP1080	800SS	8" Setback	10" setback with side stiffeners
JP1100	1000SS	10" Setback	10" setback with side stiffeners

TOURNAMENT SERIES CYLINDERS AND ADJUSTABLE TIE BAR

Extreme heavy duty cylinders and tie bars designed for primarily high performance multiple engine applications. Also available for single engine applications.

FEATURES

- ◆ Suitable for use with all SeaStar Helms & SeaStar Power Assist
- ◆ Heavy duty universal cylinder
- ◆ Bolt on stainless steel tie bar plates, also reversible (patent pending)
- ◆ Robust design with heavy duty support brackets, barrel, shaft & seals
- ◆ Superior corrosion resistance
- ◆ New pivot plate design provides smooth articulation and a sealed joint (patent pending)
- ◆ Heavy duty adjustable tie bar (patent pending)
- ◆ Equipped with stainless steel adjustable o-ring sealed elbow fittings which can be easily orientated in any direction.



TOURNAMENT SERIES CYLINDERS

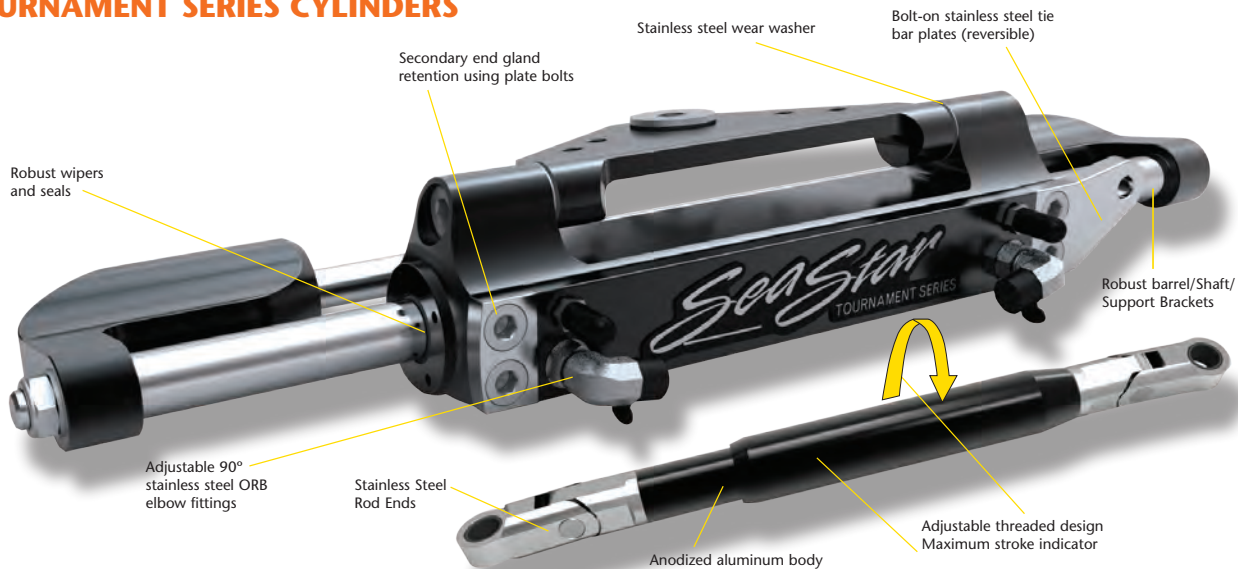

ADJUSTABLE TIE BAR

SPECIFICATIONS

ORDER INFORMATION	PART NO.
Outboard Tournament Series Cylinder, Front Mount	HC6845
Outboard Tournament Series Cylinder, Front Mount, c/w Single Engine Hardware Kit	HC6845S
Tournament Series Tie Bar, Small	HO6820
Tournament Series Tie Bar, Medium	HO6821
Tournament Series Tie Bar, Large	HO6822
Tournament Series Tie Bar, X-Large	HO6823
Tournament Series Hardware Kit Twin Engine, Single Cylinder STBD	HA6802
Tournament Series Hardware Kit Twin Engine, Dual Cylinder	HA6804
Tournament Series Hardware Kit Triple Engine, Dual Cylinder	HA6806
Tournament Series Hardware Kit Quad Engine, Dual Cylinder	HA6811
ORB Tee Fitting Kit	HF6005



Important Information:

Each configuration requires a hardware kit and tie bar kit(s), with the exception of the single engine configuration.

SEASTAR POWER ASSIST STEERING

SeaStar Power Assist steering dramatically reduces steering effort in heavy or high torque applications. SeaStar Power Assist Pro is specifically designed for high torque single engine outboard applications fitted with SeaStar Pro helms, such as performance bass boats. Power assisted steering delivers exceptional performance and unparalleled levels of safety and comfort, even in the most extreme conditions.

FEATURES:

- ◆ Dramatically reduces steering effort
- ◆ Wall or Floor mount
- ◆ Easy to install
- ◆ OEM or retro-fit
- ◆ Compatible with power purge system
- ◆ Simple add-on to an existing SeaStar steering system (from 1.4 to 2.4 SeaStar helms)
- ◆ Return to manual in failure mode
- ◆ Suitable for use with autopilots
- ◆ 12V or 24V operation
- ◆ Wiring harness included
- ◆ Ignition protected (SAE J-1171)
- ◆ ABYC, CE, NMMA, ISO 10592 Approved



PA1200-2

WHY USE POWER ASSIST?

Today's high horsepower engines are much heavier and are producing more propeller torque than ever before. Naturally, this additional weight and torque has an effect on the boat's steering when these loads are transferred to the wheel. Unacceptable levels of steering load can increase driver fatigue and discomfort. The SeaStar Power Assist virtually eliminates all steering loads and provides modern boaters the same level of steering comfort and control found in cars. Even in the most extreme applications, the boat will be more comfortable to steer. SeaStar Power Assist allows the boat to be driven safely and easily by the whole family.

SYSTEM OVERVIEW:

The SeaStar Power Assist unit can be installed on new SeaStar steering installations or as an easy retro-fit to existing systems.

Suitable for most boat types, the SeaStar Power Assist uses an electronically controlled hydraulic pump to provide on-demand power steering. It is installed into the hydraulic steering circuit between the helm and steering cylinder. The Power Assist unit is powered from the boat's battery and adjusts automatically to the input voltage (12V or 24V).

The SeaStar Power Assist can be used on boats with multiple engines and rudders, multiple steering stations and autopilots.

If power to the unit is interrupted for any reason, the steering system will automatically return to manual operation without any change to the number of lock-to-lock turns. In this case, the steering will of course be heavier than with the Power Assist activated.

Part No.	Description
PA1200-2	Power Assist, 15' Harness
PA1225-2	Power Assist, 25' Harness
PA1315-2	Power Assist PRO, 15' Harness
HA1201	Dual Ignition Control Kit
HA1206	Harness Fuse Kit

4 SEASTAR TILT STEERING KITS

HK6400TC (CLASSIC)

The kit contains the following:

- 1- HH6541 SeaStar Tilt Helm, Classic, 1.7
- 1- HC5345 SeaStar Pivot Cylinder
- 2- HA5430 Hydraulic Oil (1 Liter)

APPLICATIONS:

For use with single engine, up to 350HP



HK6400TS (SPORT)

The kit contains the following:

- 1- HH6191 SeaStar Tilt Helm, Sport, 1.7 Remote Fill
- 1- HC5345 SeaStar Pivot Cylinder
- 2- HA5430 Hydraulic Oil (1 Liter)

APPLICATIONS:

For use with single engine, up to 350HP



HK6500Y (YAMAHA)

The kit contains the following:

- 1- HH5271 SeaStar Helm 1.7
- 1- HC5358 Outboard Front Mount PP Cylinder
- 2- HA5430 Hydraulic Oil (1 Liter)

APPLICATIONS:

For use with single engine, up to 350HP



HK6500YTC (YAMAHA-CLASSIC)

The kit contains the following:

- 1- HH6541 SeaStar Tilt Helm, Classic, 1.7
- 1- HC5358 Outboard Front Mount PP Cylinder
- 2- HA5430 Hydraulic Oil (1 Liter)

APPLICATIONS:

For use with single engine, up to 350HP



XTREME STEERING

There is a quick connect feature on both the cable and spent travel tube side. You will notice the normal steering cable installation side marked on the casting for easier identification. No tools are required to snap the steering cable or spent travel tube in place which means quicker installation for the boat builder.

No bleeding of hydraulic system or electrical wiring is required. This new system fits the standard Teleflex dash cut out with standard Safe-T and 4.2 bracket. The custom helm is also available with the SH91800/SH91900 tilt mechanism.

FEATURES

- ◆ Smoothest and lowest steering effort mechanical helm offered in the market place yet still offers easy installation.
- ◆ Complete steering system including new helm, high efficiency Xtreme™ steering cable design and new style bezel.
- ◆ Quick connect feature on both steering cable and spent travel tube for easy quick installation.
- ◆ Installs in same mounting pattern and bracket location as current Teleflex Marine steering systems.
- ◆ Smallest footprint possible to accommodate small/tight dash helm stations.
- ◆ Made, designed and assembled in the USA.

COMPONENTS

This complete new steering system includes new helm, high efficiency Xtreme™ cable and new-style bezel. It is also available with Sport or Sport Plus tilt mechanism.

SSX176XX - Standard NFB System

SSX177XX - Tilt NFB System



TFXTREME CABLES

Traditional cables vary by the stiffness of the core wire and how tightly it fits in the casing. Thus the classic trade-offs that have existed in control cable design:

- ◆ Stiffer core/tighter fit offers less lost motion, but is harder to move. With longer and more complex runs, cable movement becomes progressively more difficult.
- ◆ More flexible core/looser fit has an easier feel, but allows more lost motion. This approach leads to an overall sloppy feel, RPM loss or difficult gear engagement.

THE CORE DIFFERENCE

These trade-offs aren't an issue for cables with **TFXTREME** technology because they are different — really different!

Teleflex's unique **TFXTREME** technology incorporates a patented splined core.

Ridges on the core allow a close fit with the cable's inner liner, but with minimum contact, so the core glides back and forth smoothly like a skater on ice.

RESULT: a control cable with easy movement AND minimum lost motion.

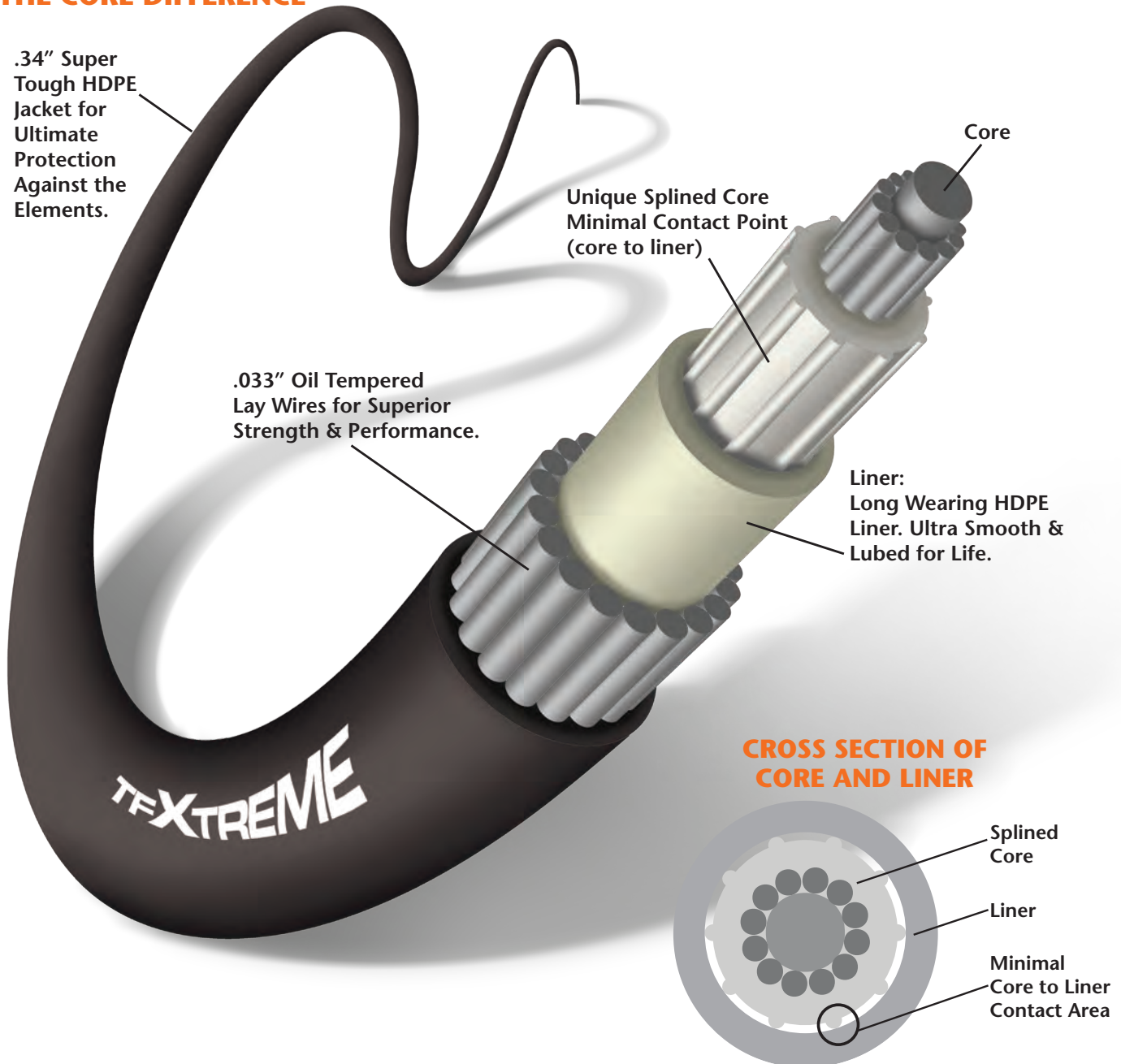

CROSS SECTION OF CORE AND LINER

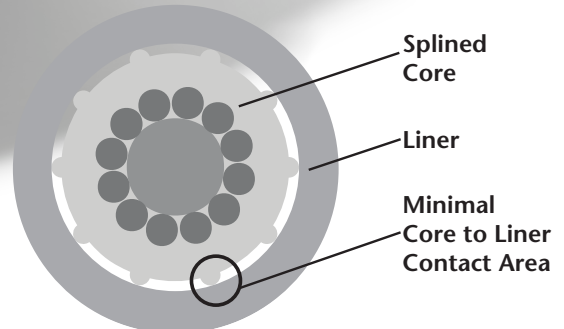

A COMPLETE FAMILY OF CABLES:

CCX189XX
Merc Gen II type
(4000 series controls)

CCX179XX
Merc type (600A)

CCX205XX
OMC type (479)

CCX630XX
3600 Merc type

CCX633XX
3300CC type
(10-32 threaded end)

CCX430XX
4300/43BC type
(1/4-28 threaded end)

CCX433XX
4300/43CC type
(1/4-28 threaded end)

CCX640XX
6400/64BC type
(5/16-24 threaded end)

CCX643XX
6400/64CC type
(5/16-24 threaded end)

Teleflex Marine
TFXTREME technology cables are
the **ONLY** high performance cable family
with a **FULL RANGE** of universal cables and
ALL popular direct replacement OEM type cables.

New Product Cross Reference

Part #	Description	OEM	OEM Part Number
18-0490	Head Gasket (o-ring)	OMC/Bombardier	335523
18-0491	Head Gasket	OMC/Bombardier	346007
18-0492	Head Gasket	OMC/Bombardier	340919
18-0690	Base Gasket	OMC/Bombardier	347205
18-0691	Base Gasket	OMC/Bombardier	
18-0692	Base Gasket	OMC/Bombardier	339601
18-0693	Intake Gasket	OMC/Bombardier	336227
18-0694	Intake Gasket	OMC/Bombardier	336226
18-0695	Intake Gasket	OMC/Bombardier	336389
18-0696	Intake Gasket	OMC/Bombardier	336388
18-1254	Vortec Head Gasket Set	Mercury Marine, 5.7L GM	27-75611A03
18-1650	3 way 1/4" FNPT Valve	Universal	
18-1651	2 way 1/4" FNPT Male/Male Shut off Valve	Universal	
18-1652	2 way 1/4" FNPT Male/Female Shut off Valve	Universal	
18-1653	2 way 1/4" FNPT Female/Female Shut off Valve	Universal	
18-1654	4 way 1/4" FNPT Valve	Universal	
18-1655	3 way 1/4" FNPT Valve w/Detent	Universal	
18-1656	3 way 3/8" FNPT Valve w/ Detent	Universal	
18-2470	Gasket, Carb Mounting	Honda	16221-ZV4-610
18-2471	Gasket, Carb Mounting	Honda	16221-ZW9-000
18-2472	Gasket, Carb Mounting	Honda	16221-ZW1-000
18-2473	Gasket, Carb Mounting	Honda	16201-881-850
18-2480	Gasket Set	Honda	16010-ZV4-005
18-2481	Gasket Set	Honda	16010-ZW9-003
18-2482	Gasket Set	Honda	16010-881-003
18-3522	Water Pump Kit w/Housing	Yamaha	60X-W0078-00 + 61A-44311-01
18-3523	Water Pump Kit w/Housing	Yamaha	68V-W0078-00 + 61A-44311-01
18-4402	Powerhead gasket kit	OMC/Bombardier	437779
18-4406	Powerhead gasket kit	OMC/Bombardier	437155
18-4420	Gasket Kit	OMC/Bombardier	439202
18-4421	Gasket Kit	OMC/Bombardier	5000400
18-4428	Gasket Kit	OMC/Bombardier	437725
18-4429	Gasket Kit	OMC/Bombardier	
18-5465	Ignition Coil	Mer cruiser	392-863704T ss 8M0054588
18-55500	Powerhead Gasket Set	Yanmar	728170-92600
18-55501	Powerhead Gasket Set	Yanmar	728171-92601
18-55502	Powerhead Gasket Set	Yanmar	728271-92605
18-55503	Powerhead Gasket Set	Yanmar	728374-92605
18-55600	Head Gasket	Yanmar	128170-01331
18-55601	Head Gasket	Yanmar	128171-01911
18-55602	Head Gasket	Yanmar	128271-01911
18-55603	Head Gasket	Yanmar	128374-01911
18-56000	Bonnet Cover Gasket	Yanmar	128170-11310
18-56601	Thermostat Gasket	Yanmar	104211-49160
18-56602	Water Pump Gasket	Yanmar	128170-42090
18-6140	Anode	Universal	301068
18-6141	Anode	Universal	301069
18-7047	Needle Valve	Honda	16011-ZV4-005
18-7048	Needle Valve	Honda	16011-881-741
18-7050	Carb Kit	Honda	
18-7051	Carb Kit	Honda	
18-7052	Carb Kit	Honda	
18-7053	Carb Kit	Honda	
18-7373N	Mercarb 2V Carburetor, New	Mer cruiser	3310-864941A01
18-7380	Float	Mercury	809569
18-7381	Float	Mercury	16253
18-7382	Float	Mercury	804184
18-7615N	Q-jet Carburetor, New	Mer cruiser/OMC	1347-804624R02/ 985822
18-7824C	Oil Filter (Chrome)		
18-7945C	Fuel Water Separater Filter(Chrome)		
18-79907	VST Filter	Yamaha	60V-24251-01-00
18-79950	Yamaha VST Kits	Yamaha	
18-79951	Yamaha VST Kits	Yamaha	
18-79952	Yamaha VST Kits	Yamaha	
18-79953	Yamaha VST Kits	Yamaha	

New Product Cross Reference

Part #	Description	OEM	OEM Part Number
18-8213	Transom Seal Kit	Mercuriser	30-803097T1
18-8217	Transom Seal Kit	Mercuriser	30-803098T1
18-8218	Transom Seal Kit	Mercuriser	30-803099T1
18-8219	Transom Seal Kit	Mercuriser	30-803100T1
18-8700	Oil Filter	Yamaha	5GH-13440-20
18-8844-1	Wire Set	Crusader	
18-8911	Impeller	Yamaha	6L5-44352-00
18-8950	Impeller	Yanmar	124223-42092
18-8951	Impeller	Yanmar	128176-42071
18-9079	Wave Washer Kit	Yamaha	
18-9180	Liquifix Degreaser 16 oz		
18-9181	Liquifix Degreaser 1 gal		
18-9182	LQ-5 Filtered Lubricant 8.5 oz		
18-9183	LQ-5 Filtered Lubricant 16 oz		
18-ADA500	STATS Tester		
18-ADA501	STATS Carry Case		
18-ADA502	STATS Tester Neoprene Case		
18-ADA503	STATS Dongle Case		
18-ADA504	STATS Neoprene Carry Case	Yamaha	
18-ADA505	STATS Carry Case	Mercury/Mercuriser	
18-ADA506	STATS Neoprene Carry Case	BRP/Seadoo	
18-ADA507	STATS Neoprene Carry Case	Kawasaki	
18-ADA508	STATS Neoprene Carry Case	Suzuki	
18-ADC152	Power Cable (AC)		
18-ADC153	USB Cable		
18-ADC300	Master Cable		
18-ADC400	Dongle A Universal		
18-ADC401	Dongle B Seadoo 4 Tech Engines		
18-ADC402	BRP Safety Key Programming Cable		
18-ADC403	Yamaha Diagnostic Cable		
18-ADC404	BRP Diagnostics Cable		
18-ADC406	Kawasaki T-In Power Cable		
18-ADC407	Mercury Diagnostic Cable		
18-ADC408	BRP T-In Power Cable		
18-ADC409	Dongle C Seadoo DI Engines		
18-ADC410	Mercury Outboard Cable		
18-ADC412	Dongle D BRP DESS (2 Stroke)		
18-ADC414	Kawasaki Power Cable(4-Stroke)		
18-ADC416	Kawasaki Fitch DI Cable		
18-ADC418	Yamaha Remote Programming Cable		
18-ADC419	Kawasaki Key Programming Cable		
18-ADC420	Suzuki 4 Pin Diagnostic Cable		
18-ADC421	Suzuki 8 Pin Diagnostic Cable		
18-ADC422	BRP DESS Diagnostic Cable		
18-ADC423	Johnson Evinrude Diagnostic Cable		
18-ADC424	Mercuriser / MEFI Diagnostic Cable		
18-ADC450	Power Cable (12v)		
18-SD102	STATS COMPLETE KIT--	Mercury/Mercuriser/MEFI, BRP, Yamaha, Suzuki	
18-SD103	STATS COMPLETE KIT--	Mercury/Mercuriser/ MEFI, BRP, Yamaha	
18-SD104	STATS COMPLETE KIT--	Mercury/Mercuriser/MEFI, BRP, Suzuki	
18-SD105	STATS COMPLETE KIT--	Mercury/Mercuriser/MEFI, Yamaha	
18-SD106	STATS COMPLETE KIT--	Mercury/Mercuriser/MEFI	
18-SD107	STATS COMPLETE KIT--	BRP	
18-SD108	STATS COMPLETE KIT--	Yamaha	
18-SD109	STATS COMPLETE KIT--	Suzuki	
18-SD110	STATS COMPLETE KIT--	SeaDoo/Yamaha/Kawasaki	
23-0400	Quad Ring	Northern Lights	
23-0830	Thermostat Gasket	Northern Lights	11-10015
23-1102	Air Filter Element	Northern Lights	24-22009
23-1103	Air Filter Element	Northern Lights	24-28003
23-1104	Air Filter	Fischer Panda	IC78.460.000B
23-1105	Air Filter	Fischer Panda	IC78.460.000A
23-2004	Impeller	Kohler	359978(impeller only)
23-2005	Impeller	Northern Lights	25-12009 (impeller only)
23-2700	Distributor Cap	Westerbeke	40859

New Product Cross Reference

Part #	Description	OEM	OEM Part Number
23-2701	Distributor Cap	Westerbeke	34113
23-2702	Distributor Cap	Westerbeke	35608
23-2703	Distributor Cap	Westerbeke	46592
23-2800	Rotor	Westerbeke	34093
23-2801	Rotor	Westerbeke	35610
23-2802	Rotor	Westerbeke	40860
23-2803	Rotor	Westerbeke	43050
23-2804	Rotor	Westerbeke	42201
23-3314	Impeller Kit	Kohler	Kohler 359978
23-3315	Impeller Kit	Northern Lights	25-12009
23-4000	Alternator Belt	Westerbeke	39181
23-4001	Alternator Belt	Westerbeke	11672
23-4002	Alternator Belt	Westerbeke	30592
23-4003	Alternator Belt	Westerbeke	45232
23-4004	Alternator Belt	Westerbeke	30475
23-4005	Sea Water Pump Belt	Westerbeke	13810
23-4006	Sea Water Pump Belt	Westerbeke	31152
23-4007	Sea Water Pump Belt	Westerbeke	30376
23-4500	Plug Wire Set	Westerbeke	43060
23-4501	Plug Wire Set	Westerbeke	46596
35-SS600	Safe Skeg		
35-SS605	Safe Skeg		
35-SS610	Safe Skeg		
35-SS615	Safe Skeg		
35-SS620	Safe Skeg		
35-SS625	Safe Skeg		
35-SS630	Safe Skeg		
35-SS635	Safe Skeg		
35-SS645	Safe Skeg		
35-SS650	Safe Skeg		
35-SS660	Safe Skeg		
35-SS665	Safe Skeg		
35-SS695	Safe Skeg		
35-SS700	Safe Skeg		
35-SSKIT1	Safe Skeg Installation Kit		
56968P	Small Engine Hourmeter	Yamaha	ENG-METER-2C-01
56969P	Sm Eng Tach/Hr		
69703P	4 Gauge Set, Sahara - Tach/Hr		
69704P	6 Gauge Set, Sahara - Tach/Hr		
69708P	4 Gauge Set, Amega - Tach/Hr		
69709P	6 Gauge Set, Amega - Tach/Hr		
69710P	4 Gauge Set, Arctic - Tach/Hr		
69711P	6 Gauge Set, Arctic - Tach/Hr		
69712P	4 Gauge Set, Eclipse - Tach/Hr		
69713P	6 Gauge Set, Eclipse - Tach/Hr		
69716P	2nd Engine OB Gauge Set, Sahara		
69717P	2nd Engine IB Gauge Set, Sahara		
69721P	2nd Engine OB Gauge Set, Amega -		
69722P	2nd Engine IB Gauge Set, Amega -		
69723P	2nd Engine OB Gauge Set, Arctic -		
69724P	2nd Engine IB Gauge Set, Arctic -		
69725P	2nd Engine OB Gauge Set, Eclipse		
69726P	2nd Engine IB Gauge Set, Eclipse		
69741P	Digital Analog Converter		
69743P	Tach/Hourmeter 7K Sahara		
RK19680	Switch, Rocker On-Off SPST BLK/GR		
RK19680TP	Switch, Rocker On-Off SPST BLK		
RK19690	Switch, Rocker On-Off-On SPDT BLK		
RK19690TP	Switch, Rocker On-Off-On SPDT BLK/GR		
TG23000	Switch, Toggle On-Off SPST		
TG23010	Switch, Toggle On-Off-On SPDT		
TG23020	Switch, Toggle On-Off-On DPDT		
TG23030	Switch, Toggle (On)-Off SPST		
TG23040	Switch, Toggle (On)-Off-(On) SPDT		

