



# SEASTAR™ JACKPLATE

## Table of Contents

1.0 Safety Information .....	2
1.1 Definitions .....	2
1.2 Before Installation.....	2
1.3 During Installation.....	3
1.4 Prior to Each Use.....	3
1.5 During Use.....	3
1.6 After Use .....	3
1.7 Maintenance.....	4
1.8 Important Labels.....	4
2.0 Jackplate Installation.....	5
2.1 Parts & Tools .....	5
2.2 Mount Jackplate to Boat.....	7
2.3 Install Relay Wiring Harness .....	9
2.4 Rocker Switch Installation .....	11
2.5 Mount Outboard to Jackplate .....	12
2.6 Clearance Checks.....	13
3.0 Limited 2 Year Warranty .....	14

## Introduction

Congratulations on your purchase of a SeaStar Jackplate. You have chosen to install one of the sleekest and most durable engine Jackplates available. Prepare for increased performance, gains in fuel economy and the ability to run in shallow water.

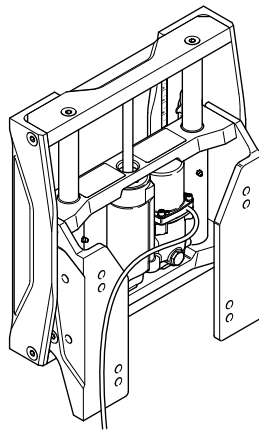

TRANSOM SIDE OF JACKPLATE  
(SHOWN EXTENDED)

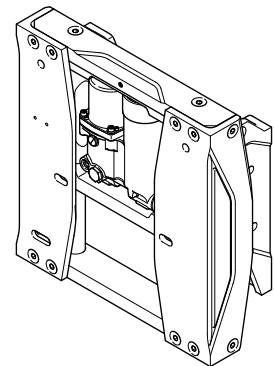

ENGINE SIDE OF JACKPLATE  
(SHOWN RETRACTED)

Figure 1. SeaStar Jackplate.



# 1.0 SAFETY INFORMATION

The safety information provided throughout this publication is intended to inform you of the dangers that may be present during installation and use. It is critical that you read and understand ALL the points noted. If you have any questions regarding any of these warnings, contact SeaStar Solutions.

## 1.1 Definitions

Throughout this manual, information for the safe installation and operation of the SeaStar Jackplate will be distinguished in one of the following ways:

### ⚠ WARNING

**Hazards or unsafe practices which could result in severe personal injury or death.**

Failure to adhere to a warning may result in loss of vessel control, leading to possible ejection from vessel causing property damage, personal injury and/or death.

### ⚠ CAUTION

**Hazards or unsafe practices which could result in minor injury or product or property damage.**

### NOTICE

*Important information in regards to installation, use and maintenance of the SeaStar Jackplate.*

## 1.2 Before Installation

The safe operation of the SeaStar Jackplate is dependent upon proper installation and maintenance, common sense, safe judgment and the knowledge/expertise of the operator. Every installer/user of the Jackplate should know the following requirements **before** installing/using the SeaStar Jackplate.

1. Read and understand the Installation and Owner's Manuals provided with your steering components.
2. Ensure that all components required to complete the installation are on hand.
3. SeaStar components are highly engineered and safety tested to ensure system integrity; DO NOT substitute any component with non-SeaStar components as this may compromise system performance/reliability.
4. Comply with all system ratings/regulations (boat/engine, U.S.C.G.).  
- Jackplate MUST be rated for use on the engine(s) installed.

### ⚠ WARNING

**The MAXIMUM supported engine weight is 625 lbs, dry weight.**

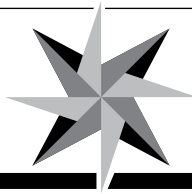

## 1.3 During Installation

1. Install components as directed in all Installation Instructions.
2. DO NOT modify or substitute any component in any way without written consent from SeaStar Solutions.
3. Confirm that there is no interference between the SeaStar Jackplate and the steering cylinder(s), tiebars, steering hoses, outboard engine, outboard engine hoses or any combination of these parts by performing the CLEARANCE CHECKS as detailed in Section 2.6.

## 1.4 Prior to Every Use

1. Verify immediate response when switch is engaged (UP/DOWN).
2. Inspect the Jackplate for damage, cracks, deformation, wear and binding. Check for loose mounting bolts and/or nuts.

DO NOT OPERATE BOAT IF ANY COMPONENT IS NOT IN PROPER WORKING CONDITION.

### ⚠ CAUTION

**DO NOT attempt to steer with the engine at full tilt. Damage to the Jackplate and/or steering components could occur.**

## 1.5 During Use

To reduce risk of severe injury or death, always wear a Coast Guard Approved personal flotation device (PFD) and use an engine shut-off cord (lanyard).

### ⚠ CAUTION

**Damage to outboard will occur if proper water pressure is not maintained while the boat is under way. Raising the outboard too high will result in a water pressure drop and overheating of your outboard engine will occur. Proper water pressure must be maintained at all times during operation of the outboard.**

### ⚠ CAUTION

**DO NOT attempt to steer with the engine at full tilt. Damage to the Jackplate and/or steering components could occur.**

## 1.6 After Use

1. Rinse off Jackplate and steering cylinder thoroughly using fresh, clean water only.
  - Cleaning fluids containing ammonia, acids or any other corrosive ingredients MUST NOT be used for cleaning any part of the Jackplate.



## 1.7 Maintenance

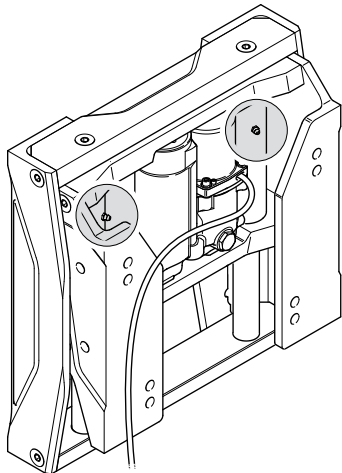

Figure 2. Grease fitting locations.

**After first use and every 100 hours or 6 months thereafter (whichever comes first).**

1. Ensure the transom bolts and engine bolts are torqued to their installed values.
2. Inspect the Jackplate for damage, cracks, wear and binding. Inspect the Jackplate brackets, guide rods, guide rod seals, actuator shaft and actuator shaft seal. Check for leaking components.
3. Inspect electrical cables for damage.
4. Lubricate the guide rods by pumping general marine grease into each of the bearing tubes via the grease fittings identified in Figure 2.

## 1.8 Important Labels

### ⚠ WARNING

The safety information provided below is intended to inform you of the warning information on your products. Contact SeaStar Solutions if labels are missing.

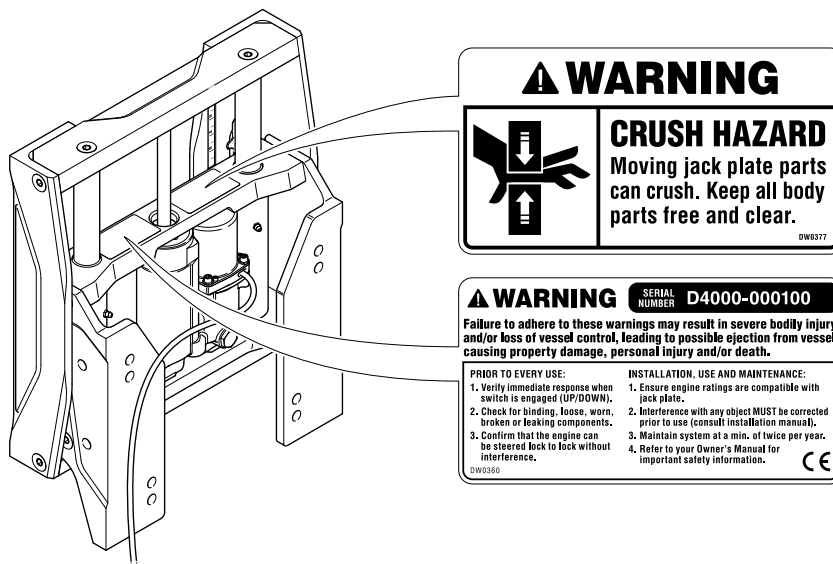
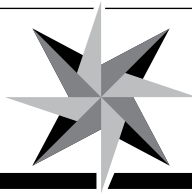

Figure 3. Safety labels.



## 2.0 JACKPLATE INSTALLATION

Before proceeding with the installation, read these instructions thoroughly. SeaStar Solutions cannot accept responsibility for installations where instructions have not been followed, where substitute parts have been used, or where modifications have been made to our products.

### **⚠ WARNING**

**Failure to adhere to these instructions may result in loss of boat control, leading to possible ejection from vessel causing property damage, personal injury and/or death.**

## 2.1 Parts & Tools

If you have questions or feel that you can not properly install this hydraulic Jackplate, **STOP** immediately and call us at 604-248-3858.

### **INCLUDED PARTS**

- [1] Jackplate
- [2] Relay Wiring Harness
- [3] Rocker Switch
- [4] 3 x Spade Terminals
- [5] 4 x 1/2" SAE Stainless Steel Washers (*For outboard to Jackplate mounting*)

### **OTHER TOOLS, EQUIPMENT**

- Floor crane/Overhead hoist
- Torque wrench
- Outboard engine lifting eye

### **⚠ WARNING**

**The use of 6 mounting bolts is recommended for installations of 10" or 12" setbacks or for outboard engines with output greater than 250 horsepower.**

### **OTHER CONNECTION HARDWARE (NOT SUPPLIED)**

- Marine sealant suitable for below waterline use.

### **Jackplate to Transom Connection:**

- 4 x Stainless steel outboard engine bolts supplied by or approved by the engine manufacturer.
- 8 x 1/2" Stainless steel washers supplied by or approved by the engine manufacturer.
- 4 x 1/2" Brass nuts with nylon locking elements supplied by or approved by the engine manufacturer.

### **NOTICE**

*If setback is 10" or more and/or outboard engine output is greater than 250 HP, the use of 6 sets of mounting hardware to mount the Jackplate to the transom is recommended. Refer to warning.*

### **⚠ WARNING**

**In the absence of engine supplied hardware, bolts must conform to ASTM F593C and have a minimum yield strength of 55 000 psi.**

### **Outboard Engine to Jackplate Connection:**

- 4 x 1/2"-20 UNF Stainless steel bolts that conform to ASTM F593C and have a minimum yield strength of 55 000 psi.
- 4 x 1/2" Stainless steel washers supplied by or approved by the engine manufacturer.
- 4 x 1/2"-20 UNF Brass nuts with nylon locking elements.

### **NOTICE**

*If the outboard engine manufacturer has supplied instructions on Jackplate installation, then those guidelines must be followed during installation.*



## NOTICE

The use of a transom stiffener for the top bolts on the transom side of the jackplate-to-transom connection is recommended.

## ⚠ WARNING

Check the outboard engine manufacturer's instructions carefully for specifications regarding connection hardware. Ensure the outboard engine manufacturer's requirements are followed.

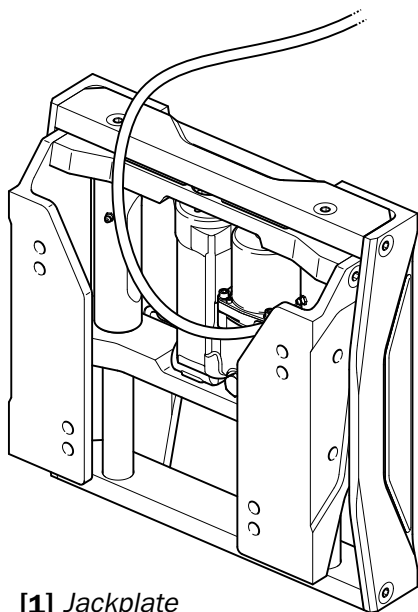

[1] Jackplate

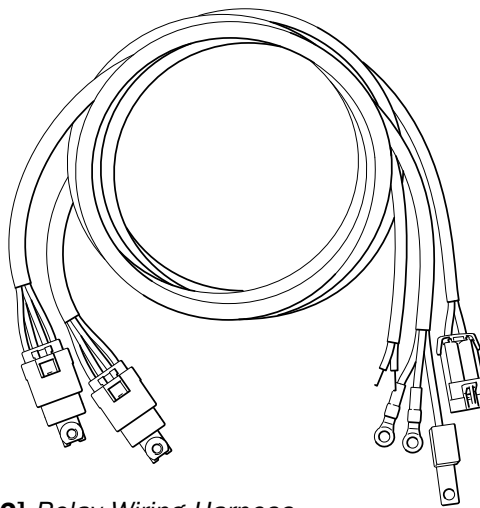

[2] Relay Wiring Harness

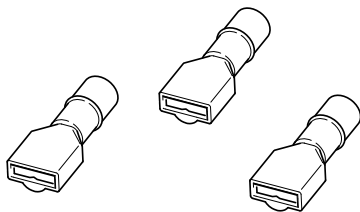

[4] Spade Terminals (Female)

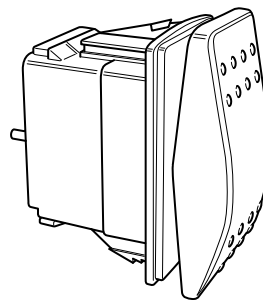

[3] Rocker Switch

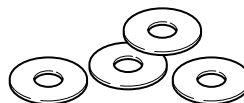

[5] 1/2" SAE Stainless Steel Washers

Figure 4. Included parts.

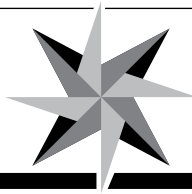

## 2.2 Mount Jackplate to Boat

### NOTICE

Temporarily connecting the relay wiring harness will allow actuation of the Jackplate. This may assist insertion of the engine bolts. See Section 2.3.

### NOTICE

The lower port side bolt may be difficult to install. Adjusting the Jackplate height to the 2.5" position may allow for easier insertion.

### ⚠ WARNING

**CRUSH HAZARD.** Moving Jackplate parts can crush. Keep all body parts free and clear when actuating the Jackplate.

### ⚠ WARNING

Use of non-approved bolts and washers may lead to separation of engine from boat.

### ⚠ WARNING

Follow the outboard engine manufacturer's recommendations for tightening torque.

### ⚠ WARNING

The use of 6 mounting bolts is recommended for installations of 10" or 12" setbacks or for outboard engines with output greater than 250 horsepower.

1. Insert the 4 engine bolts into the engine side of the Jackplate prior to mounting the Jackplate on the transom. Use the four 1/2" SAE washers supplied.
2. Using connection hardware supplied by or approved by the outboard engine manufacturer, mount the Jackplate to the transom.

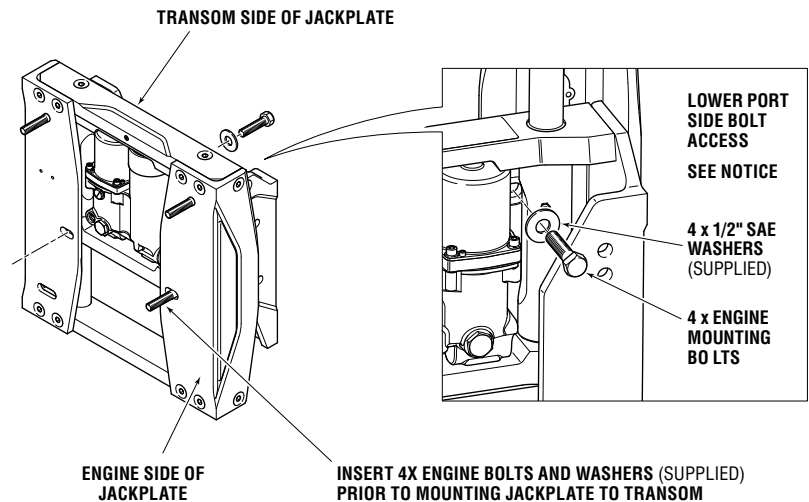

Figure 5. Engine bolt insertion.

3. If the Jackplate setback is 10 inches or more, or if the outboard engine output is 250 horsepower or more, it is recommended to use 6 mounting bolts at the transom connection. Additional mounting bolts should be used in the upper holes on the Jackplate hole pattern. See Figure 8.
4. Seal all holes in the transom with an appropriate marine sealant.

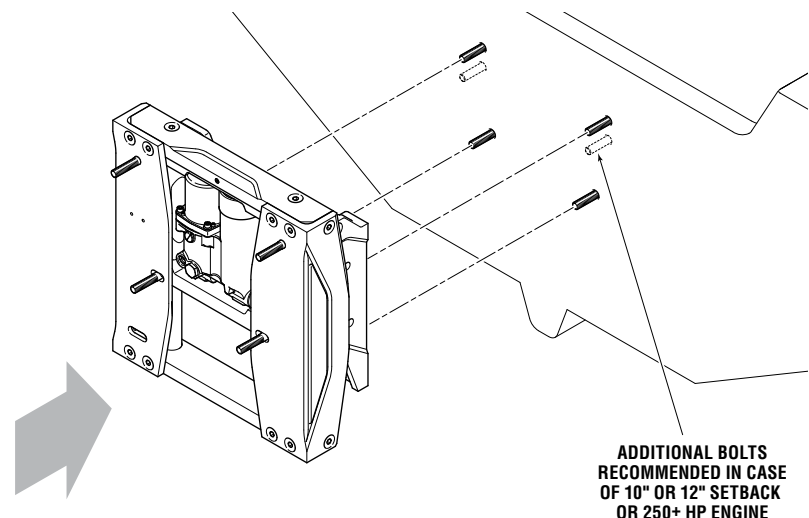

Figure 6. Jackplate to transom connection.

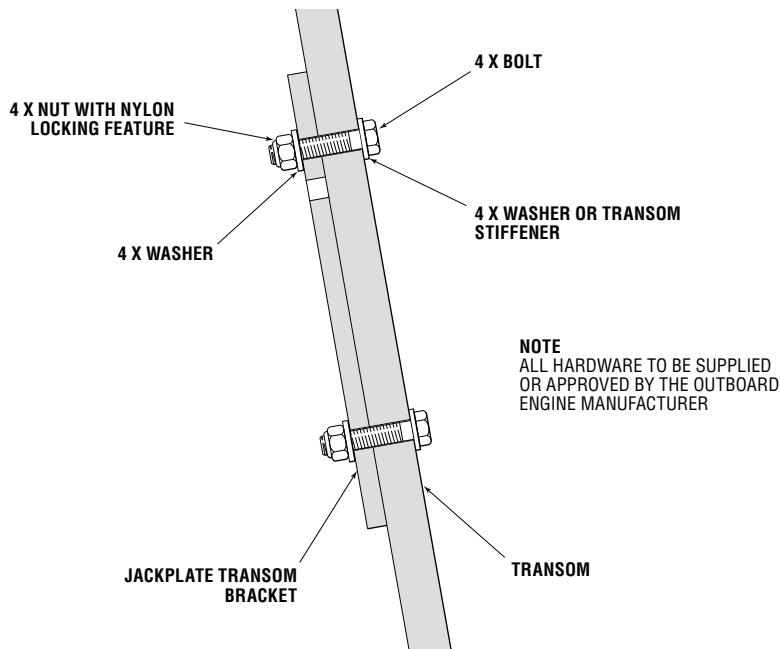

Figure 7. Jackplate to transom connection.

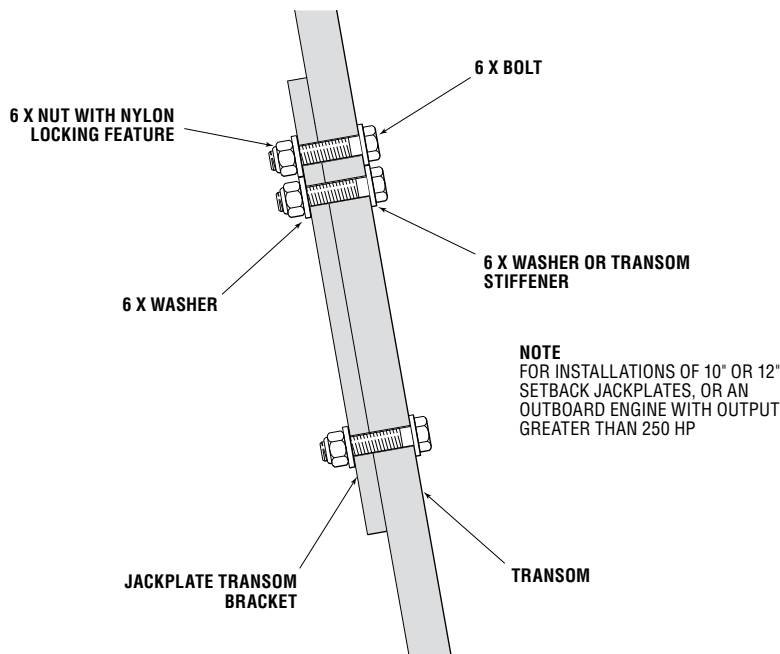

Figure 8. Jackplate to transom connection for 10" or 12" setbacks, or for outboards greater than 250 HP.

- 6. Using a torque wrench, tighten the nuts to the manufacturer's recommended torque.

Record the torque values here for future reference.

\_\_\_\_\_ ft-lbs. \_\_\_\_\_ Nm.





## 2.3 Install Relay Wiring Harness

### ⚠ CAUTION

Before operating the Jackplate, check mounting bolt clearances and ensure that shift and throttle cables, electrical lines, and fuel hoses are clear of the Jackplate so they will not be pinched or kinked when the unit is moved up and down.

1. Find a dry and accessible place to mount the Relay Wiring Harness. Use the mounting holes on the relay brackets to secure the harness to the boat.

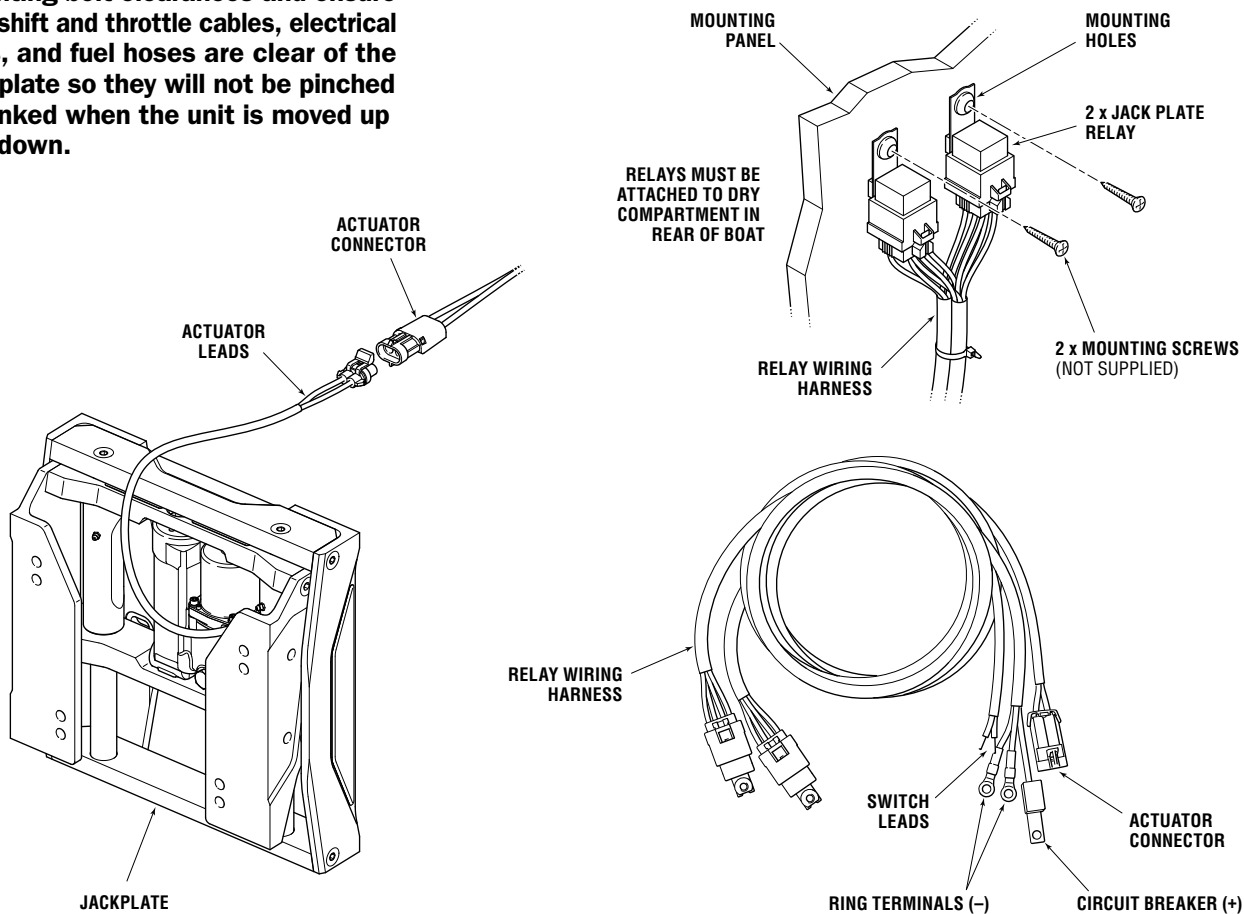

Figure 9. Relay Wiring Harness installation and connections.

### ⚠ CAUTION

Ensure the harness has proper strain relief and is routed to avoid damage/pinching/chafing.

2. Attach the brass bar from the circuit breaker to a 12V positive (+) post on the outboard engine battery.
3. Attach the 2 black ring terminals to a negative (-) post on the same battery as step 2.

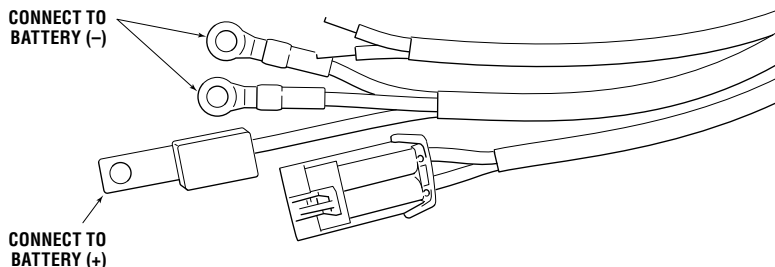

Figure 10. Battery connections.



## Main Wiring Diagram

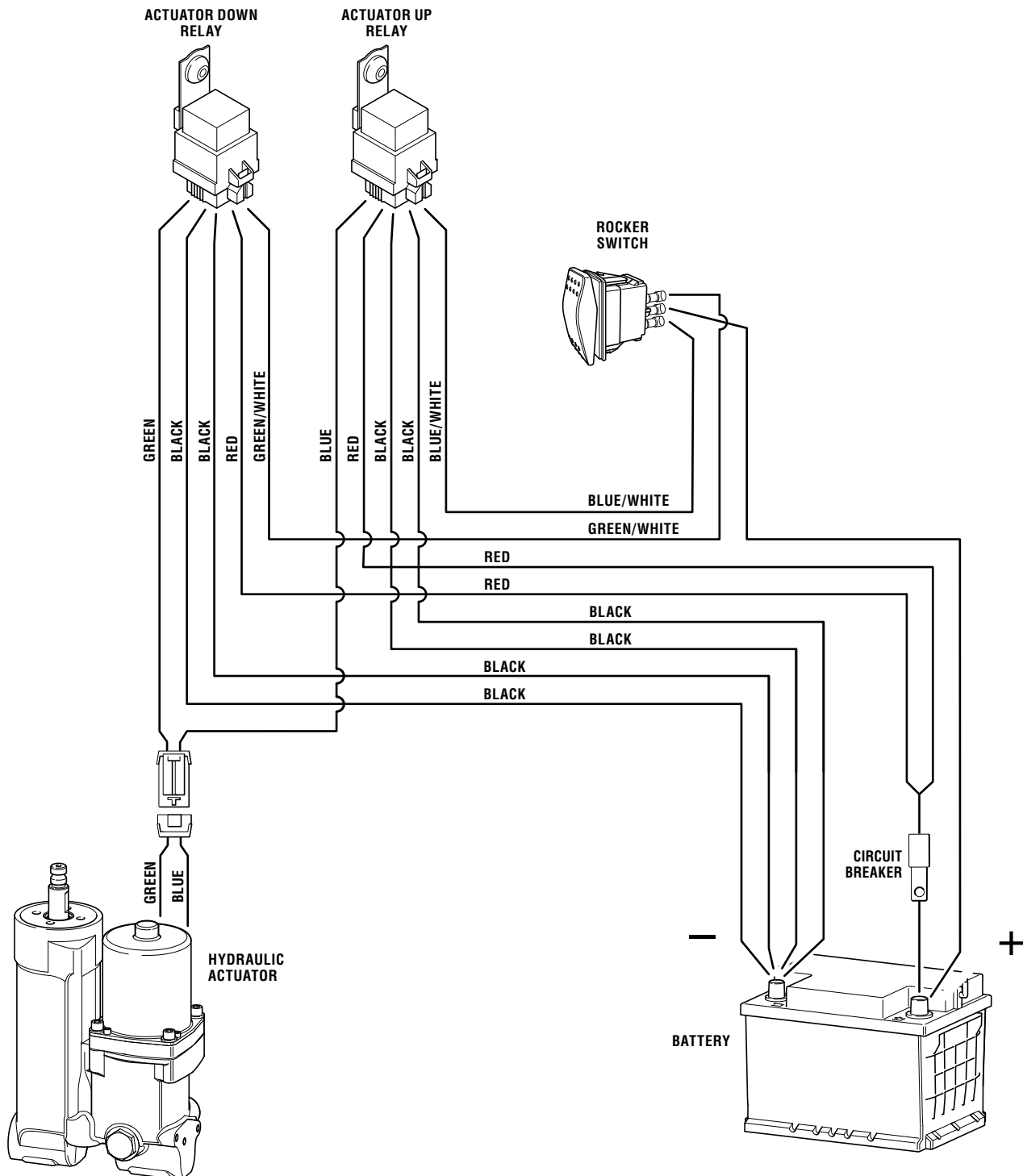
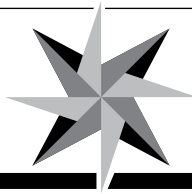

Figure 11. Main Wiring diagram.



## 2.4 Rocker Switch Installation

### NOTICE

Position the rocker switch so that it is within easy reach of the operator.

### NOTICE

The switch leads from the relay wiring harness may not be long enough to reach the rocker switch position on the dashboard or console. In this case you will need to extend the leads.

### ⚠ CAUTION

**Any additional wire spliced to the Relay Wiring Harness must be marine grade and meet SAE J1128.**

### ⚠ CAUTION

**Any wire from a 12V(+) source must be protected with an appropriate fuse or circuit breaker.**

### NOTICE

If the Jackplate actuation direction is inconsistent with the rocker switch direction, swap the positions of the GREEN/WHITE and BLUE/WHITE wires on the switch spades.

### ⚠ CAUTION

**Ensure the harness has proper strain relief and is routed to avoid damage/pinching/chafing.**

1. Cut an appropriate rectangular opening in the dashboard or console panel where you intend to mount the rocker switch.

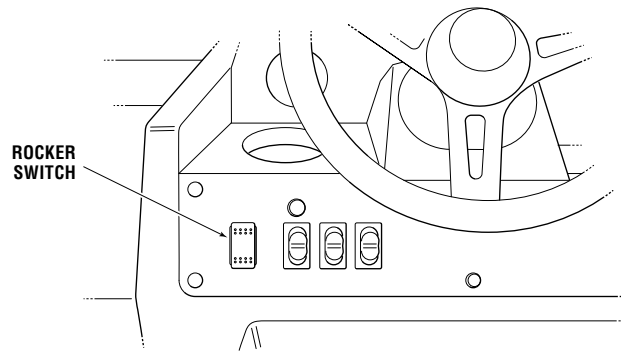

Figure 12. Rocker Switch on dash.

2. Route the switch leads from the relay wiring harness to the hole in the dashboard.
3. Terminate the end of the switch leads with the supplied spade terminals.
4. Route an additional 16AWG wire from a 12V (+) position on the fuse panel or from the battery and terminate with a supplied spade terminal.
5. Attach the wires to the spades on the back of the rocker switch. The wire from the 12V (+) source should attach to the CENTER spade on the rocker switch.
6. Do not seat the switch into the dash until after the rest of the installation is complete and you have confirmed the Jackplate direction is consistent with the switch direction.

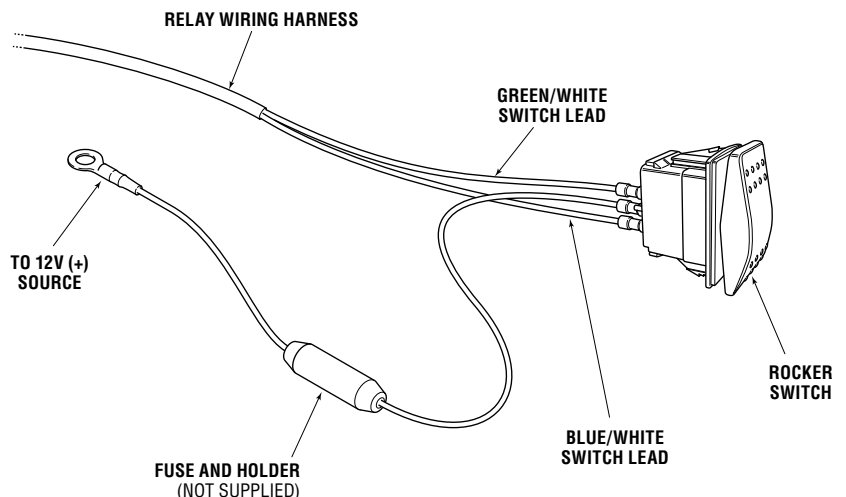

Figure 13. Rocker Switch connections.



## 2.5 Mount Outboard to Jackplate

### ⚠ WARNING

All engine mounting hardware must conform to the standards specified in Section 2.1.

1. Using an appropriate hoist and lifting eye, lift the outboard into place.
2. Select the hole set on your outboard engine that will best suit your boat and application.
3. Move the engine forward on the hoist while feeding the bolts into the mounting holes.
4. Install the washers and nuts and tighten. Ensure you use approved bolts, nuts and washers. See Section 2.1.
5. Using a torque wrench, tighten to **90 ft-lbs. (122 Nm)**.

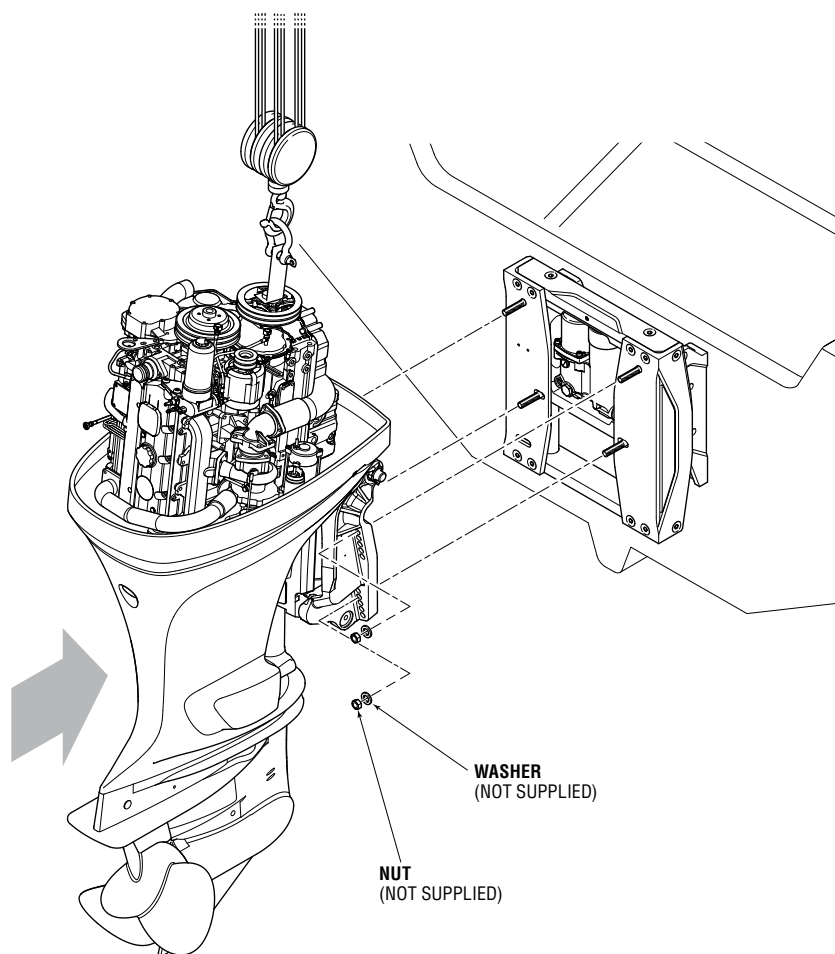

Figure 14. Outboard installation.

### ⚠ CAUTION

Perform the Clearance Checks prior to water testing.

### ⚠ WARNING

The **MAXIMUM** supported engine weight is 625 lbs, dry weight.

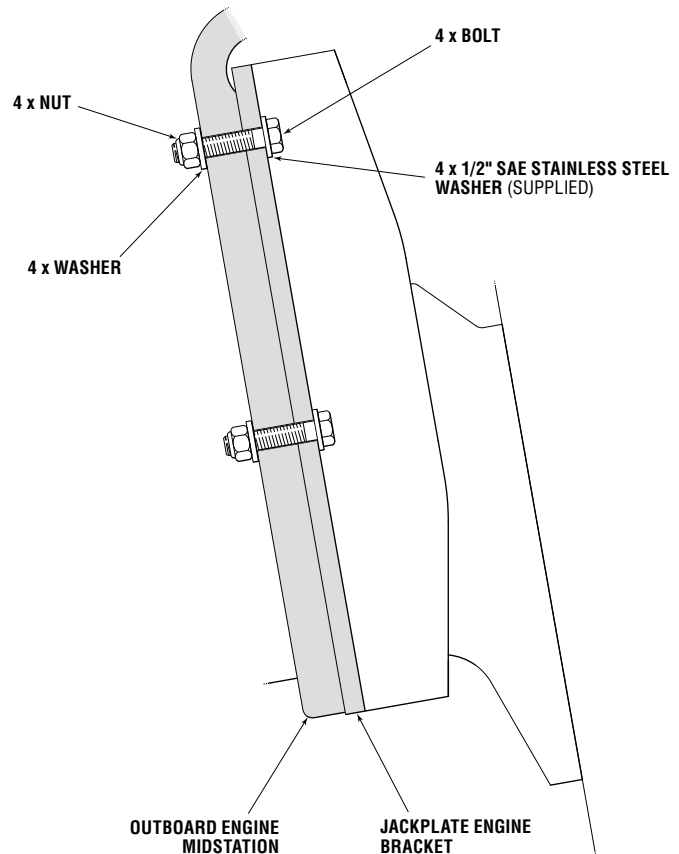
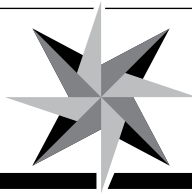

Figure 15. Outboard Engine to Jackplate connection.

## 2.6 Clearance Checks

### ⚠ WARNING

**Jackplate clearance checks MUST be completed after installation. Failure to adhere to this warning may result in the loss of vessel control, leading to possible ejection from vessel causing property damage, personal injury and/or death.**

1. Starting with the Jackplate at its lowest position, verify full steering travel through the entire trim range.
2. At the full down position, with the steering at center, CAREFULLY tilt the engine and verify that no interference occurs as the outboard engine is tilted. Check for interference between the steering components and the Jackplate in all steering positions.
3. If any interference exists, you must take action and do one of the following:
  - a. Add a tilt limiter device to the outboard engine and ensure it is set to prevent the engine from reaching a position where interference is possible.
  - b. Move the engine up to the next set of mounting bolt holes.

### ⚠ WARNING

**Interference with any object MUST be corrected prior to use.**



## 3.0 LIMITED 2 YEAR WARRANTY

We warrant to the original retail purchaser that Marine Canada Acquisition Inc. DBA SEASTAR SOLUTIONS (herein forward referred to as SeaStar Solutions) products have been manufactured free from defects in materials and workmanship. This warranty is effective for two years from the date of original retail purchase, excepting that where SeaStar Solutions products are used commercially or in any rental or other income producing activity, then this warranty is limited to 1 year from the date of original purchase.

We will provide replacement product without charge, for any SeaStar Solutions product meeting this warranty, which is returned (freight prepaid) within the warranty period to the dealer from whom such products were purchased, or to us at the appropriate address. In any such case SeaStar Solutions products found to be defective and covered by this warranty, will be replaced or repaired at SeaStar Solutions' option, and returned to the customer.

SeaStar Solutions' sole responsibility under this warranty is limited to the repair or replacement of product which is, in SeaStar Solutions' opinion, defective. SeaStar Solutions is not responsible for charges connected with the removal of such product or re-installation of replacement or repaired parts.

We will have no obligations under this warranty for any product:

- Which has been improperly installed.
- Which has been used in an installation other than as recommended in our installation or operation instructions or specifications.
- Which has failed or has been damaged due to an accident or abnormal operation including racing, misuse or alterations outside our factory.
- Which has been repaired or modified by other than SeaStar Solutions.
- Which has been used on an engine/boat combination where the engine horsepower exceeds the boat horsepower rating established by the boat manufacturer.
- Which has been used with other products which, in SeaStar Solutions' opinion, are incompatible with the SeaStar Solutions product.

THIS WARRANTY IS EXPRESSLY IN LIEU OF ANY OTHER WARRANTIES, OBLIGATIONS OR LIABILITIES ON THE PART OF SEASTAR SOLUTIONS AND WILL BE THE CUSTOMER'S EXCLUSIVE REMEDY EXCEPT FOR ANY APPLICABLE IMPLIED WARRANTIES UNDER STATE LAW WHICH ARE HEREBY LIMITED IN DURATION TO TWO YEARS FROM THE DATE OF ORIGINAL PURCHASE. IN NO EVENT WILL SEASTAR SOLUTIONS BE LIABLE FOR ANY INCIDENTAL OR CONSEQUENTIAL DAMAGES FOR BREACH OF ANY EXPRESS OR IMPLIED WARRANTY RELATING TO THE PRODUCTS.

Some states do not allow limitations on an implied warranty, or the exclusion of incidental or consequential damages, so the above exclusions may not apply to you. You may have other rights which vary from state to state.

If SeaStar Solutions products are to be returned to SeaStar Solutions under warranty, you must obtain a Return Goods authorization number (claim number) prior to shipping. Be sure to label the goods with:

- a) the name and address of the sender, and
- b) the return goods authorization number (claim number).

Please address the returned goods as follows:

**From U.S.A.**

RGA # ?  
SeaStar Solutions  
c/o UPS-Supply Chain Solutions Inc.  
Door A37  
201 C Street NW, Auburn, WA,  
98001

**From CANADA and Overseas**

RGA # ?  
SeaStar Solutions  
3831 No.6 Road,  
Richmond, B.C.  
Canada V6V 1P6