

Hynautic

5/16" O.D. NYLON TUBE FITTING

⚠ CAUTION

Ensure the seal is not twisted during installation.

⚠ CAUTION

Extreme care **MUST** be taken to avoid any contamination from entering the tubing. Failure to do so may lead to system failure.

- 1 Cut tubing using a tube cutter, leaving the cutoff end as square as possible.
- 2 Slip the nut over the tubing end—(nut should slide freely).
- 3 Push the lock over the end of the tubing and move it back at least one insert length from the end. The lock may slide on freely or require a light press or screw-on action. (The lock has a left hand thread)
- 4 Install the seal over the end of the tubing and against the lock. Refer to Caution.
- 5 Then force the insert into the end of the tubing by pushing it against a clean, flat surface.
- 6 Push the nut and the lock by hand toward the end of the tube as far as possible.
- 7 Insert the tube end assembly into the proper cavity and tighten it down. Tighten only to a solid feel on the wrench.

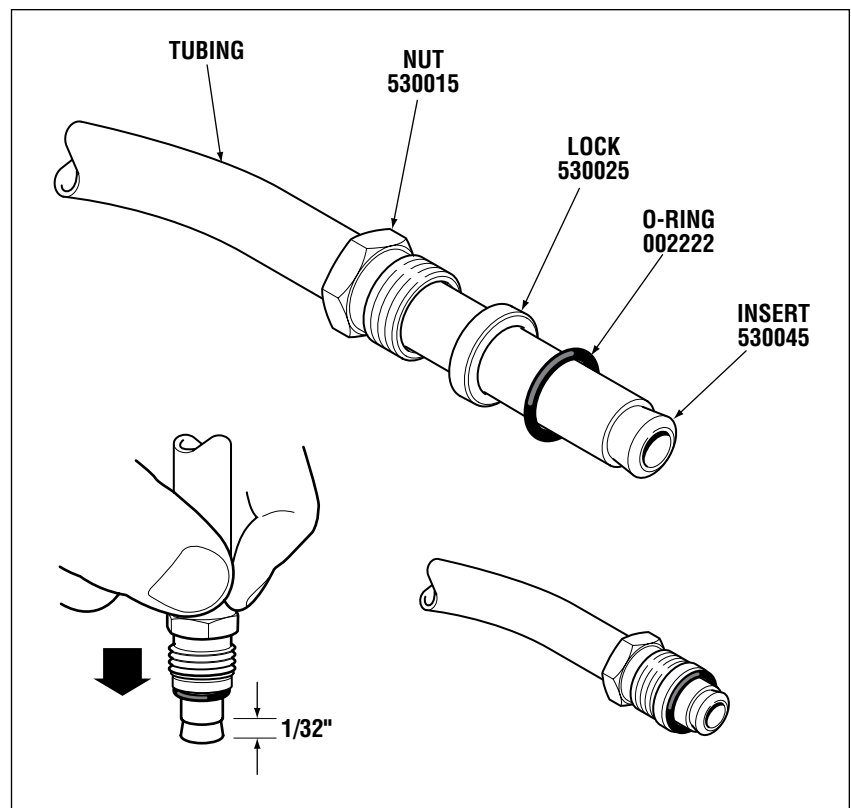

Figure A.