

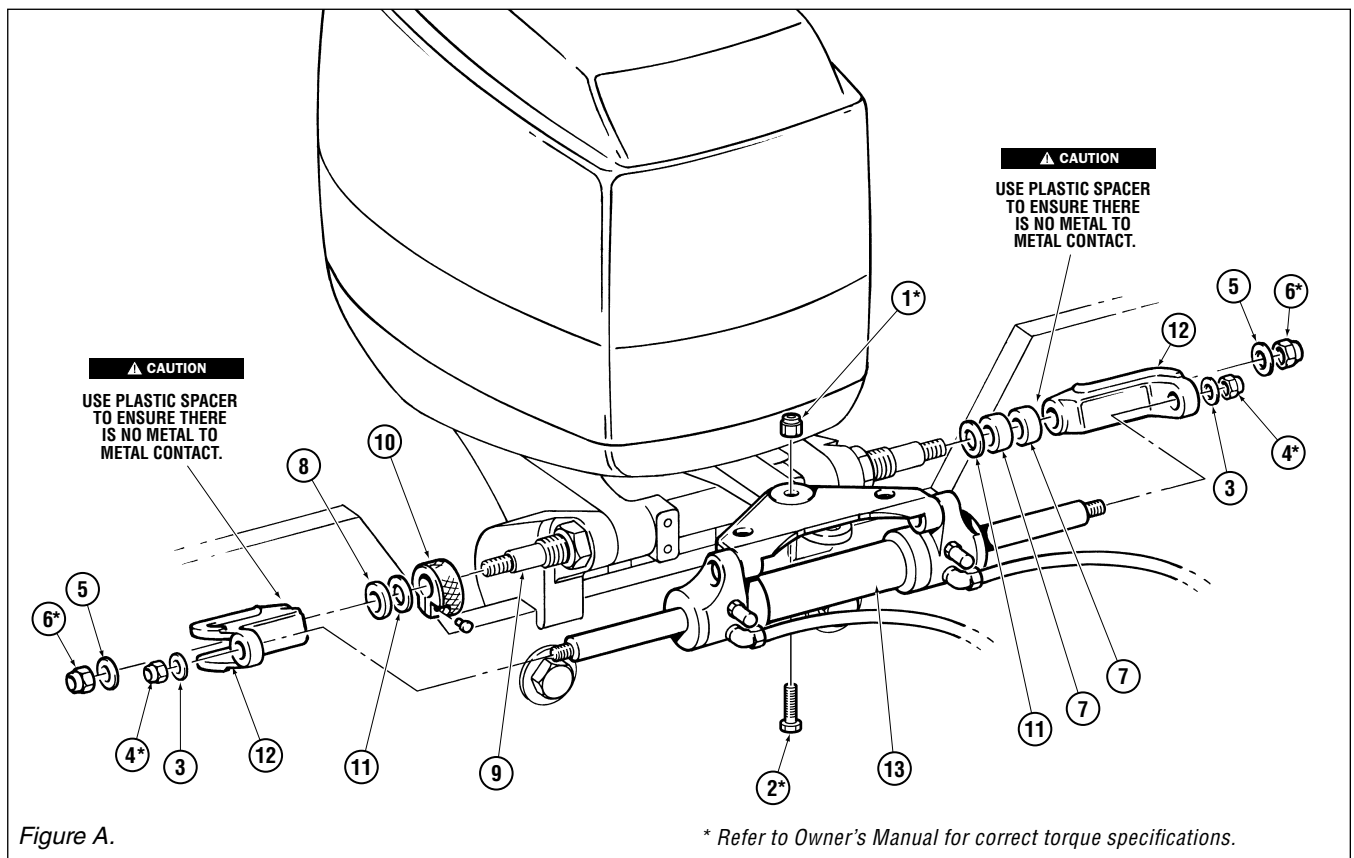

FRONT MOUNT CYLINDER PART #HC5445, YAMAHA INSTALLATION

ENGINE MANUFACTURER	YEAR	MODEL	CYLINDER	NOTES
YAMAHA	2010 TO DATE	4.2L V6	HC5445	Stroke reduced cylinder.



ITEM	PART #	QTY	DESCRIPTION
*1	113529	1	Nut, 3/8" NF Nylok® SS
*2	113225	1	HHCS 3/8" UNJF x 1.35" HSS
3	731625	2	Washer Flat, 7/16" SS
*4	731720	2	7/16" NF Nylok SS
5	202027	2	Washer, Flat 1/2" SS
*6	192126	2	Nut 1/2" NF Nylok® ni plt br
7	995876	2	Spacer, Thick, Plastic
8	996689	1	Spacer, Thin, Plastic
9	730229	1	Support Rod

ITEM	PART #	QTY	DESCRIPTION
10	828085	1	Adjusting Nut and Screw SS, Teflon Coated
11	202300	2	Washer, Flat 5/8" SS
12	839120	2	Support Brackets
13	HC5445	1	Pivot Mount Cylinder
14	728994	1	Spacer, Medium (Not Used)
15	113330	1	HHCS, 3/8" NF x 1-3/8" SS