

SeaStar Solutions Graphic Standards 2017



why use Graphic Standards?

1

The focus of a visual identity at any company is usually its logo, but the following pages reflect a comprehensive identity system - including logo and word mark, typefaces, color palettes and design templates - for presenting information logically and consistently.

These standards will enable SeaStar Solutions to achieve clarity, accuracy and efficiency in all print and electronic communications. Implementation of these standards will develop greater awareness of the company as a whole while enabling divisions, departments and programs to communicate effectively as distinct entities.

Vision for Graphic Design Standards

Perhaps the most powerful, tangible evidence of an organization's promise is its visual identity. This guide was developed to ensure that who we are and how we are perceived are one and the same. By using this guide, you will not only help solidify our identity but also help us realize our ideals.

In order to create and build the brand for SeaStar Solutions, the standards and guidelines presented in this manual are important and expected to be followed by everyone.

Embracing and following these standards will be advantageous to the entire company, allowing us to achieve clarity and effectiveness in all print and electronic communications.

It is impossible to cover all potential uses and applications of the new identity; therefore, this manual is intended to be an introduction and a guide to basic components of the identity system.

Our commitment to establishing a successful graphic identity will be demonstrated in the brand identity we produce. When the graphic system is fully implemented, the identity will consistently distinguish all publications and advertising, all print, electronic and audio-visual materials.

Central Points

The Company logo, motto, word mark, and official symbols are the only graphics approved to represent our company. No one is permitted to develop their own logos. The design or use of any other logo representing the company is prohibited.

The logo and word mark may be used individually or combined in the manner shown in this guide. No other combinations are permitted. Use only approved digital art of the logo and word mark.

Quality and Coordination

The Marketing Department will oversee the graphic design standards to ensure we maintain graphic design awareness, consistency and excellence. Please direct your questions and requests for information to the SeaStar Solutions Marketing Department.

index

LOGO, TYPEFACE AND COLOR GUIDES

01	Introduction - Why use Graphic Standards	45	Corporate electronic stationary
02	Index	46	Brand letter
03	Our identity	47	Brand electronic stationary
04	Graphic engineering	48-49	Other business letters
05	Our operating marine businesses	50-51	Corporate business cards
06	Our brands	52	Brand business cards
07	Isolation area	53	Other business cards
08	Color program	54-55	Power point template
09	Single color	56-57	Data sheets
10	Dark background	58	Technical manuals
11	Typography - general use	59	Press releases
12	Typography - designers	60	Dealer electronic promotions
13	Identity position - why top left?	61	Other electronic promotions
14	Identity position - centered	62	Product advertising
15	Incorrect use of the identity	64	Corporate advertisement
16	Correct use of the identity	64-65	Exhibition graphics
17	Incorrect use of typography		
18	Correct use of typography		
19	Using the 'globe' logos		
20	Genuine products		
21	The symbol as a graphic device		
22	The symbol as a graphic element		
23-24	Our mechanical steering brands		
25	Hydraulic steering brands		
26	Sierra & sierra product brands		
27	Shields logo		
28	Inca logo		
29	BluSkies logo		
30	MDI logo		

LAYOUTS FOR DESIGNERS

31	Layouts and grids
32	Standard product brochure cover
33	Standard product brochure grid
34	Standard product brochure spread
35	Standard product brochure grid
36	Product impact brochure
37	Product impact brochure grid
38	Product impact brochure spread
39	Product impact brochure grid
40-41	Image placement and quality
42-43	Quality standards in reproduction
44	Corporate letter

CONSUMER VIEW

66	Consumer view
67	Layouts and grids
68	Packaging
69	Product endorsement
70	Displays and Point of Sale
71	Signage
72	Web site
73	Social media
74-75	Clothing and gifting
76	Sales tools
77	International size templates
78	International examples
79-80	Technical glossary

our identity



Star	Text
icon	Logo Type - Based on Arial Regular
Black 30%	bespoke adjustments
Black 60%	SEASTAR - C100 M75 Y0 K20
Solid Black	SOLUTIONS - Black 60%

making
our mark

SeaStar Solutions® logo.

The eight sided Star is designed specifically to provide a cohesive center point for our brands.

SeaStar® is a recognized trade mark throughout the marine industry.

Strong graphic elements reinforce direction and movement.

Our SeaStar Solutions® logo is the mark of our visual identity.

The usage of the basic elements should always be in accordance with the guidelines outlined in this Design Manual. Each visual element can strengthen or weaken our public image. Therefore, it is essential that we produce all visual communication under the direction of the outlines set out in the following pages, in order not to compromise our identity.

graphic engineering

Precision engineered elements collectively create quality performance when working together

precision parts

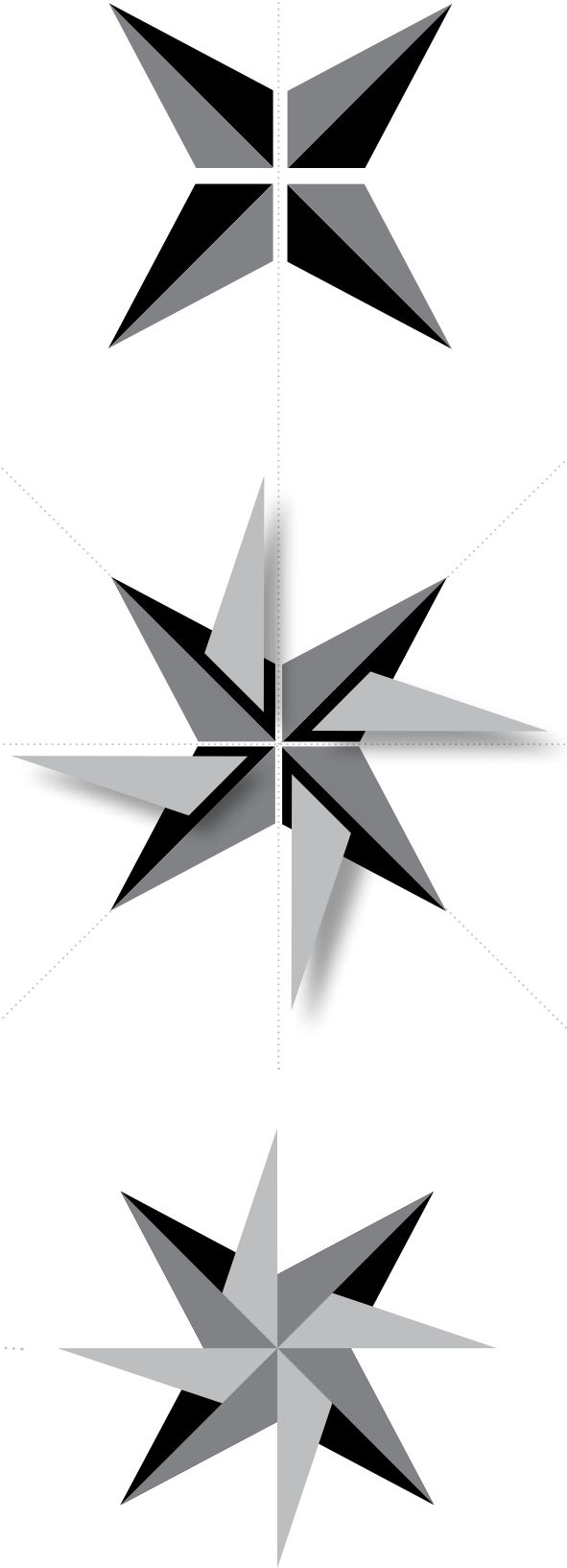

our operating marine businesses

Hydraulic Steering Systems
 Engine and Drive Parts
 Shields Hose
 Mechanical Steering
 Controls and Cables

our ethos
 making



Sierra Marine Engine and Drive Parts
 Over 6000 parts.



SeaStar
 Superior outboard hydraulic steering systems.



BayStar
 Hydraulic steering for lower powered outboards.



Optimus EPS
 High performance hydraulic steering systems.



Xtreme Mechanical Steering
 The best mechanical steering systems.



NFB
 Our registered 'No Feed Back' Logo, for mechanical steering systems.



Shields Hose
 The best quality marine hoses.



OnBoard Rewards
 Dealers build reward points through our OnBoard Rewards program.



INCA Molded Products INC
 Manufacturers of the first permanently installed cross-linked polyethylene fuel tank in the marine industry.



BluSkies
 Marine Fuel tanks and fuel systems.



MDI
 Marine Digital Integrators.

our brands

SeaStar Solutions® provides a cohesive center point for our core businesses.

precision
parts

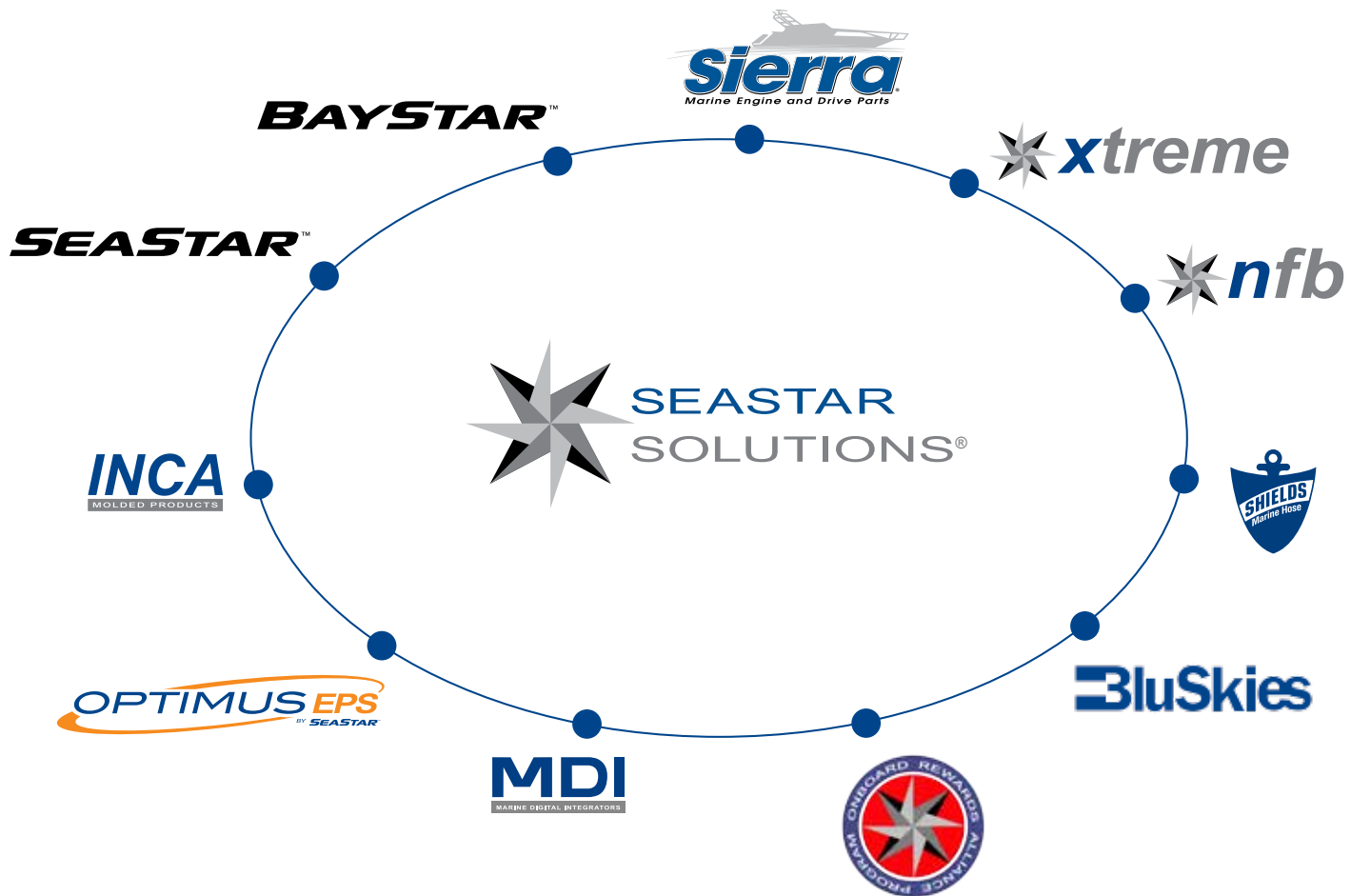

isolation area

CMYK Preferred use of the logo.

The Logo should not be reproduced less than 1" width
If you have a requirement for a smaller logo contact:
SeaStar Solutions



Protective area - allow free space around logo



allowing space



Here is an example of how the isolation area protects the way a logo is viewed.

If the logo is crowded with text, images or graphics it can become lost or overpowered, losing the impact, clarity and purpose of the identity.



color program

Primary Colors

SeaStar - CMYK - Blue

C - 100%
M - 75%
Y - 0
K - 20%



CMYK - Blue

C - 100%
M - 75%
Y - 0
K - 20%

RGB - Blue

R - 0
G - 69
B - 140

Pantone Blue - 280

Pantone Blue - 280

Solutions - Dark Gray

K - 60%
Pantone Cool Grey 11

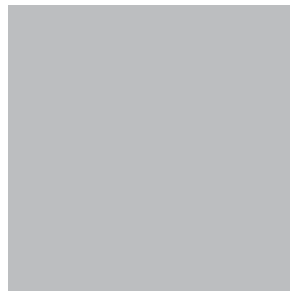

Light Gray

K - 30%
Pantone Cool Grey 6
Use for the Sierra and
Shields Grey Logos

Star - Light Gray

K - 30%
Pantone Cool Grey 6



Dark Gray

K - 60%
Pantone Cool Grey 11
Also for all other single
color Grey logo's

Star - Dark Gray

K - 60%
Pantone Cool Grey 11

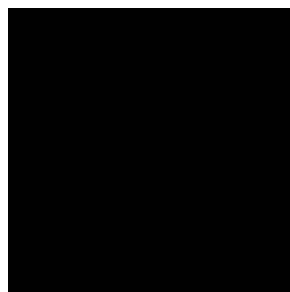

Black

K - 100%

Star - Black

K - 100%

Complementary Colors



CMYK - Orange

M - 55%
Y - 100%

RGB - Orange

R - 246
G - 139
B - 31

Pantone Orange - 021

single color

When a single color version is required we have provided 4 colors, Black, Blue, Gray and White.



Black
K - 100%



Pantone Blue - 280



Gray - 60% Black or
Pantone Cool Gray 11



White reversed

dark backgrounds - 'keyline' logo



With a dark background use the 'Keyline' version.
The area of isolation still applies. Avoid text and elements interfering with the logo.

**adding
impact**

typography - general use

Arial & Helvetica Neue

Easy to read, contemporary sans serif design.

These typefaces contain more humanist characteristics than many of their predecessors and as such is more in tune with modern thinking and styles. The overall treatment of curves is softer and fuller than in most industrial style sans serif faces. Terminal strokes are cut on the diagonal which helps to give these faces a less mechanical appearance. Extremely versatile family of typefaces which can be used with equal success for text setting in reports, presentations, magazines etc, and for display use in newspapers, advertising, promotions and digital media.

Arial Regular

SeaStar Solutions

Arial Italic

SeaStar Solutions

Arial MT Pro Medium

SeaStar Solutions

Arial Bold

SeaStar Solutions

Arial Bold Italic

SeaStar Solutions

Arial Black

SeaStar Solutions

Helvetica Neue (TT) Thin

SeaStar Solutions

Helvetica Neue (TT) Light

SeaStar Solutions

Helvetica Neue (TT) Regular

SeaStar Solutions

Helvetica Neue (TT) Medium

SeaStar Solutions

Helvetica Neue (TT) Bold

SeaStar Solutions

Helvetica Neue (TT) Condensed Black

SeaStar Solutions



Titles

Arial MT Pro Medium - 25pt with 30pt leading - (preferred)

SeaStar Solutions

Headings

Arial MT Pro Medium - 16pt with 20pt leading - (preferred)

SeaStar Solutions

Arial or Helvetica Bold - 16pt with 20pt leading

SeaStar Solutions

Arial or Helvetica Black - 16pt with 20pt leading

SeaStar Solutions

Sub Headings

Arial or Helvetica Bold - 12pt with 15pt leading

SeaStar Solutions

Body Text

Arial Regular - 9pt with 15pt leading - (preferred)

SeaStar Solutions

Arial MT Pro Medium - 9pt with 15pt leading

SeaStar Solutions

typography - designers

Titles adjusted type

Vertical scale 80%
Horizontal 100%
Tracking set to 0

Arial MT Pro Medium - 25pt with 25pt leading - (preferred)

SeaStar Solutions

Headings adjusted type

Vertical scale 80%
Horizontal 100%
Tracking set to 0

Arial MT Pro Medium - 16pt with 16pt leading - (preferred)

SeaStar Solutions

Arial Bold - 16pt with 16pt leading

SeaStar Solutions

Arial Black - 16pt with 16pt leading

SeaStar Solutions

Sub Headings

Arial Bold - 12pt with 15pt leading

SeaStar Solutions

Body Text

Vertical scale 100%
Horizontal 100%
Tracking set to 0

Arial Regular - 9pt with 15pt leading - (preferred)

SeaStar Solutions

Arial MT Pro Medium - 9pt with 15pt leading

SeaStar Solutions

arial, easy
to read

identity position - why top left

Western language users read left-right, top down. This has also transposed to website designs. The other common analogy, a store front still (mainly) has the logo at the top.

It's therefore important to establish common usage to create a cohesive outward impression.

Stationary items should consistently show the logo in the top left

Examples include:

Word doc letterhead

Word doc Bulletin

Word doc Memo

Internal News Bulletins

Printed Business cards

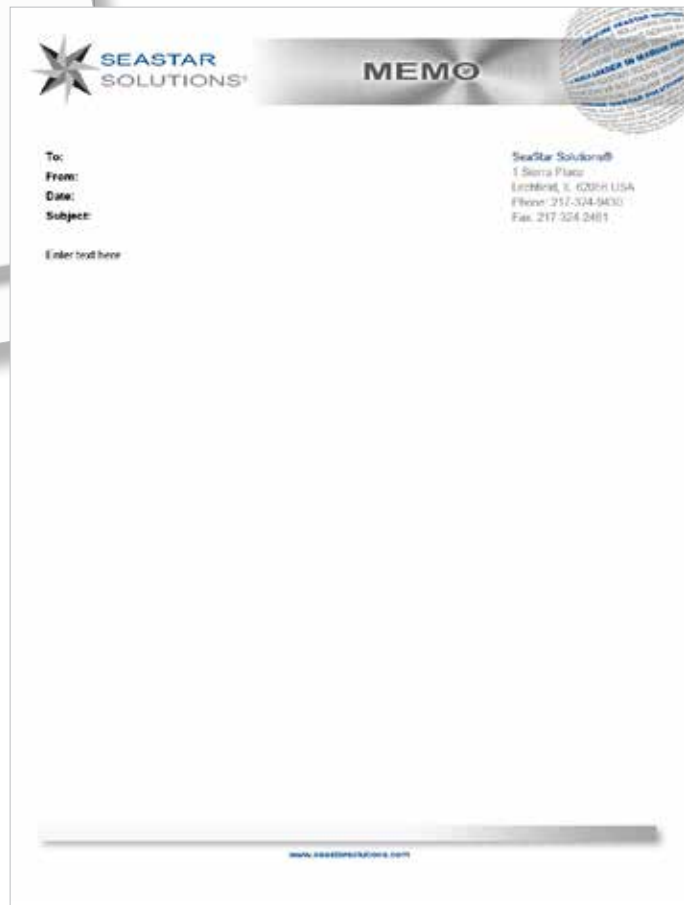

see layouts/stationary for full grid specifications section 2 p43

identity position - centered

There will not be many instances where we use the identity in a centered position. Used mainly when you want to draw attention to the identity as the key feature ie: a corporate advertisement about SeaStar Solutions.



incorrect use of the identity

Simple do's and don't's will help maintain the clarity of the identity. These are some of the more obvious ways in which the identity can be badly misrepresented.

◀ don't



Don't use the identity over a background that's darker or dominant



Don't use the single color identity when printing in 4 color process



Don't write or apply graphics over or around the identity



Don't place the identity over imagery



Don't use the identity where definition is not clear



Don't use the identity under 1" width

correct use of the identity

do ▶

Basic principles should be adhered to, for example the identity should be clear and defined against backgrounds. Below are examples of how to correctly apply the identity.



Use the 4 color identity where the background is adjusted



Use the 'Keyline' identity where the background is darker or dominant



Don't write
Always keep to the area of isolation



Use the single color identity **only** when printing in single color



Use the 'Keyline' identity for clarity



Use the 'Mini logo at 100%' for small scale applications

incorrect use of typography

◀ don't

don't use other typefaces

don't use other colors

too much information..

In a brochure or advertisement can put the customer off.

Overload of technical information without illustrations and/or images to reinforce points of interest will lose customers attention.

correct use of typography

do

In modern times, typography has been put into motion.

In film, television and online broadcasts adding emotion to mass communication.

With good typography, text is composed to create a readable, coherent, and visually satisfying whole that works invisibly, without the awareness of the reader. Even distribution of typeset material, with a minimum of distractions and anomalies, is aimed at producing clarity and transparency.

 [see layouts/brochures for examples section 2 p32](#)

Impact heading

- **Bullet points**
- **Keep it simple and concise**
- **Features and benefits**

Body Text:

Arial Regular - 9pt with 15pt leading - (preferred)

SeaStar Solutions

Arial MT Pro Medium - 9pt with 15pt leading

SeaStar Solutions

In typography, color is the overall density of the ink on the page, determined mainly by the typeface, but also by the word spacing, leading and depth of the margins.

Text layout, tone or color of the set text, and the interplay of text with the white space of the page in combination with other graphic elements impart a “feel” or “resonance” to the subject matter.

Typographers are also concerned with binding margins, paper selection and printing methods when determining the correct color of the page.

Legibility ‘refers to perception’

Readability ‘refers to comprehension’

Typographers aim to achieve excellence in both.

Use our color range with typography.

60% black heading.



Hydraulic steering

outboard systems

Our outboard hydraulic cylinder features upgrades to the barrel, sealing system and fittings. These upgrades are designed to keep pace with the introduction of heavier higher horsepower engines found on today's new boats.

inbo

The SeaStar dual rudder, easy autopilot, anodized and sealed ports

tour syst

Extreme heat designed for engine applications

SEASTAR

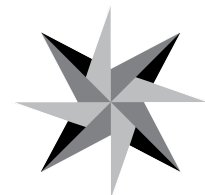

using the 'globe' logos

Our genuine globe logo's are used for product endorsement, primarily for packaging but can also be added to product technical information, data sheets and product brochures.

The genuine globe logo's are designed to give reassurance to customers that they're using a quality, well built product.

SeaStar



SEASTAR™ BAYSTAR™

OPTIMUS EPS™
BY SEASTAR

Examples of good use of a GENUINE SEASTAR globe (not to scale)

For backgrounds
Use as a 10-20% tint of black



genuine products

Shields



Sierra



All 4 globe logos are available in color and single color versions

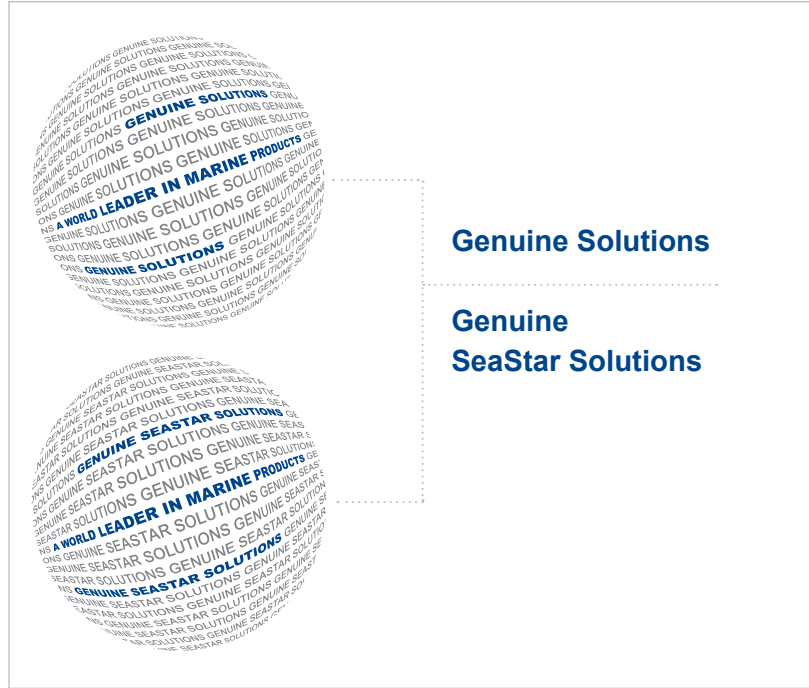

Genuine Solutions

Genuine SeaStar Solutions



Solid Black

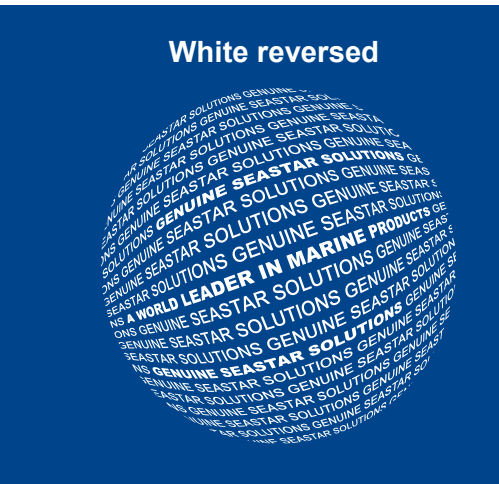

White reversed



Pantone 280 Blue

Genuine Products are endorsed with our Original Equipment logo



the symbol as a graphic device

You can use the 'Star' symbol on its own.
Use the same guides and principles for the symbol as the identity.
Please refer to page 17-18 for do's and don't's.

The symbol requires an area of isolation when used as a main component but can be used in the background as a graphic element.

Using the symbol on its own

As the 'Star' becomes more widely recognized it can be used independently of the full identity.

Some examples of good use of the 'Star' logo:

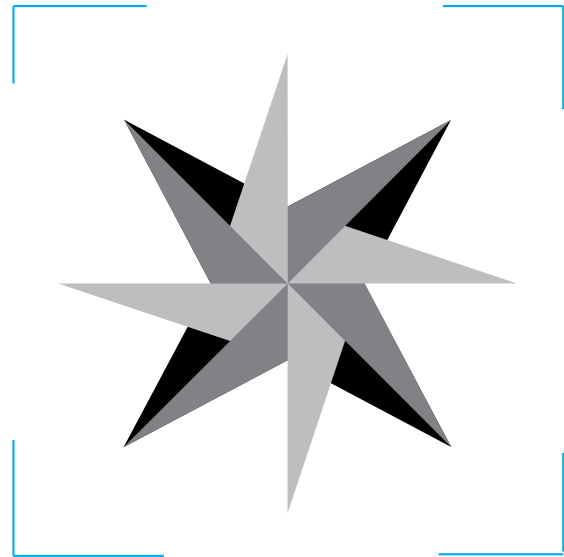

Protective area - allow free space around logo



don't



the symbol as a graphic element

Graphic element

Some examples of good use of the 'Star' logo as a graphic element set to 20% of solid.



Graphic element

Some examples of good use of the 'Star' logo as a graphic element.



our mechanical steering brands



You will see the 'Star' brand across our Mechanical steering packaging and products.

Easy to recognize as part of the SeaStar Solutions® family using the colors and typeface according to these guidelines pages 7-8.



Where the logo's are restricted in size use the smaller versions for clarity.

Logo pack contains various colors and sizes.

making
our mark



Dark Gray text



Star ref page 7 Blue ref page 8



uniformity

Star	Text
icon	Logo Type - Based on Arial bold italic
Black 30%	bespoke adjustments
Black 60%	Black 60%
Solid Black	Blue C100 M75 Y0 K20



hydraulic steering brands

SEASTAR™

OPTIMUS EPS
BY SEASTAR

OPTIMUS 360
BY SEASTAR

 **SEASTATION**
BY SEASTAR



Under the SeaStar Hydraulic Steering brand there are specific logo's to use for specific products.

Use the supplied logos in the logo pack.

Follow the same guidelines as the SeaStar Solutions Logo pages 7-8.

BAYSTAR™

BAYSTAR™

CAPILANO™

BAYSTAR™

SEASTAR™
PA



SEASTAR™
PRO

SEASTAR
JACKPLATE

sierra & sierra product brands

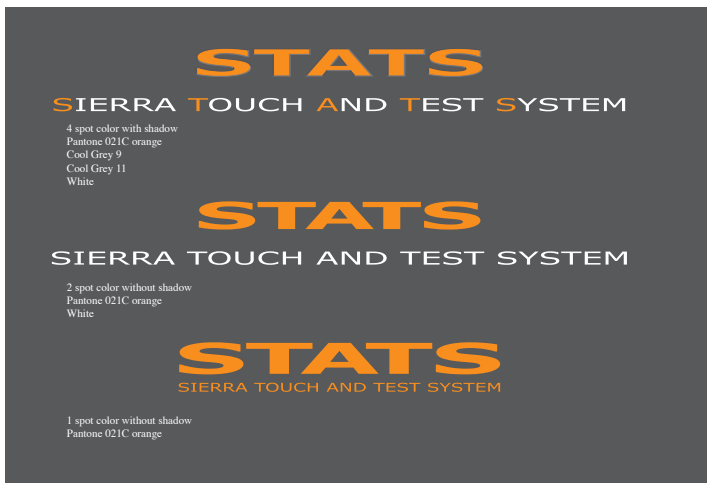

Under the Sierra brand there are specific logo's to use for specific products.

Use the supplied logos in the logo pack.

Primary Colors



CMYK - Blue **RGB - Blue**
 C - 100% R - 0
 M - 75% G - 69
 Y - 0 B - 140
 K - 20%

Pantone Blue - 280

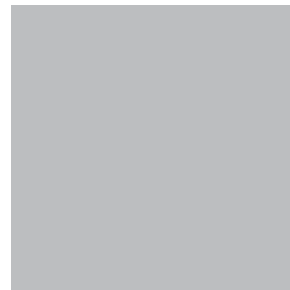

Light Gray
 K - 30%
 Pantone Cool Grey 6
 Use for the Sierra and Shields Grey Logos



Dark Gray
 K - 60%
 Pantone Cool Grey 11

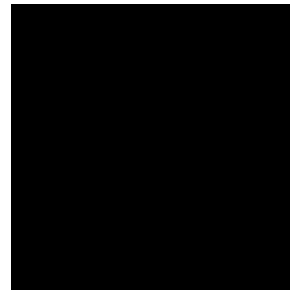

Black
 K - 100%

Complementary Colors



CMYK - Orange
 M - 55%
 Y - 100%

Pantone Orange - 021

RGB - Orange
 R - 246
 G - 139
 B - 31

shields



Shields Hoses are key to the SeaStar Solutions® extensive product range. Use the colors according to these guidelines page 26.

Logo pack contains various colors and formats.



inca molded products



INCA Molded Products, INC. is an acquisition by SeaStar Solutions®. Use the colors according to these guidelines pages 7-8.

Logo pack contains various colors and formats.



BluSkies Marine Fuel Tanks and Fuel Systems



BluSkies is a recent acquisition for SeaStar Solutions®. Use the colors according to these guidelines pages 7-8.

Logo pack contains various colors and formats.



MDI Marine Digital Integrators



MDI is an acquisition by SeaStar Solutions®.
Use the colors according to these guidelines pages 7-8.

Logo pack contains various colors and formats.



for designers

2

The following section covers grid layouts and guidelines for designers and art workers. Without stifling creativity, the following grids and layouts will give pointers to form a uniform look to our literature, stationary, web design and social media.

Quality is key, when using quality imagery and design

this can only reflect our company's outward image at all times.

layouts and grids

Creating a uniform for the company

Product impact brochures



Product semi technical information brochure



Product technical data sheet



standard product brochure cover

4 page semi technical information brochure
(scaled down) -Templates available

Highlight column for products or features

Brand position 2



Brand position 1

Use our color range
30% black
60% black
Black
Blue
Orange

Identity position 1

Main image

standard product brochure grid

8.5 inches wide x 11 inches deep

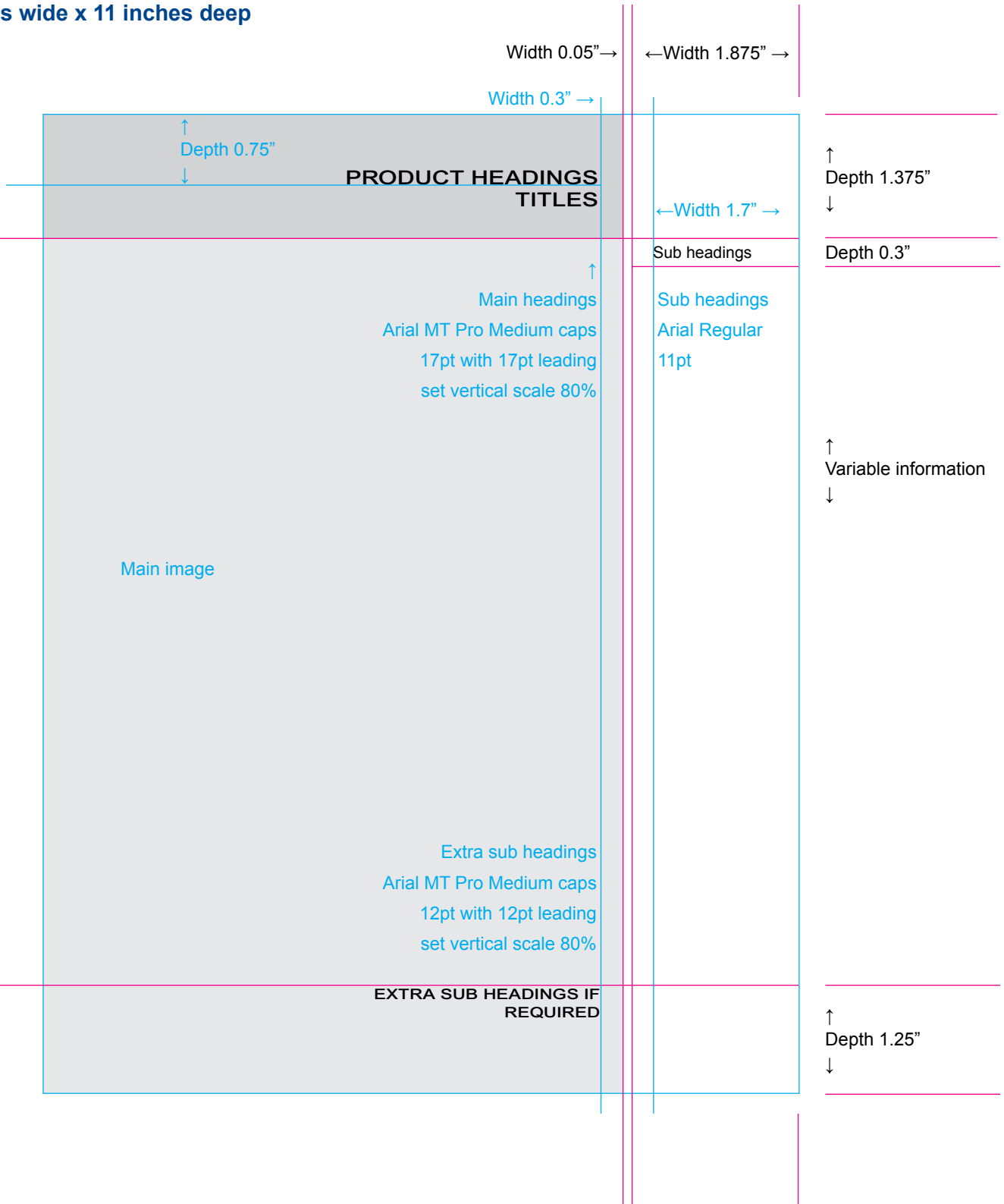

standard product brochure spread

4 page and 6 page examples - Templates available ✓



Titles

Vertical scale 80%

Horizontal 100%

Tracking set to 0

Arial MT Pro Medium - 25pt with 25pt leading - (preferred)

Helvetica Neue - for impact (not adjusted)

Branding



Use our color range

30% black

60% black

Black

Blue

Orange



Add our complimentary colors - see page 40

standard product brochure grid

8.5 inches wide x 11 inches deep

<p>Examples</p> <p>Titles titles</p>	<p>Examples</p> <p>Headings</p> <p>Sub Headings</p> <p>Body text Arial Regular</p>	<p>Headings Vertical scale 80% Horizontal 100% Tracking set to 0</p> <p>Arial MT Pro Medium - 16pt with 16pt leading - (preferred)</p> <p>Arial Bold - 16pt with 16pt leading</p> <p>Arial Black - 16pt with 16pt leading</p> <p>Sub Headings Arial Bold - 11-12pt with 15pt leading</p> <p>Body Text Vertical scale 100% Horizontal 100% Tracking set to 0</p> <p>Arial Regular - 9pt with 15pt leading - (preferred)</p> <p>Arial MT Pro Medium - 9pt with 15pt leading</p>
--	--	--

Set up for InDesign
Page size 11" x 8"
2 column spreads with 0.16" gutter
All margins 0.5"

product impact brochure

4 page semi technical information brochure
(scaled down) - Templates available ✓

Highlight area if required

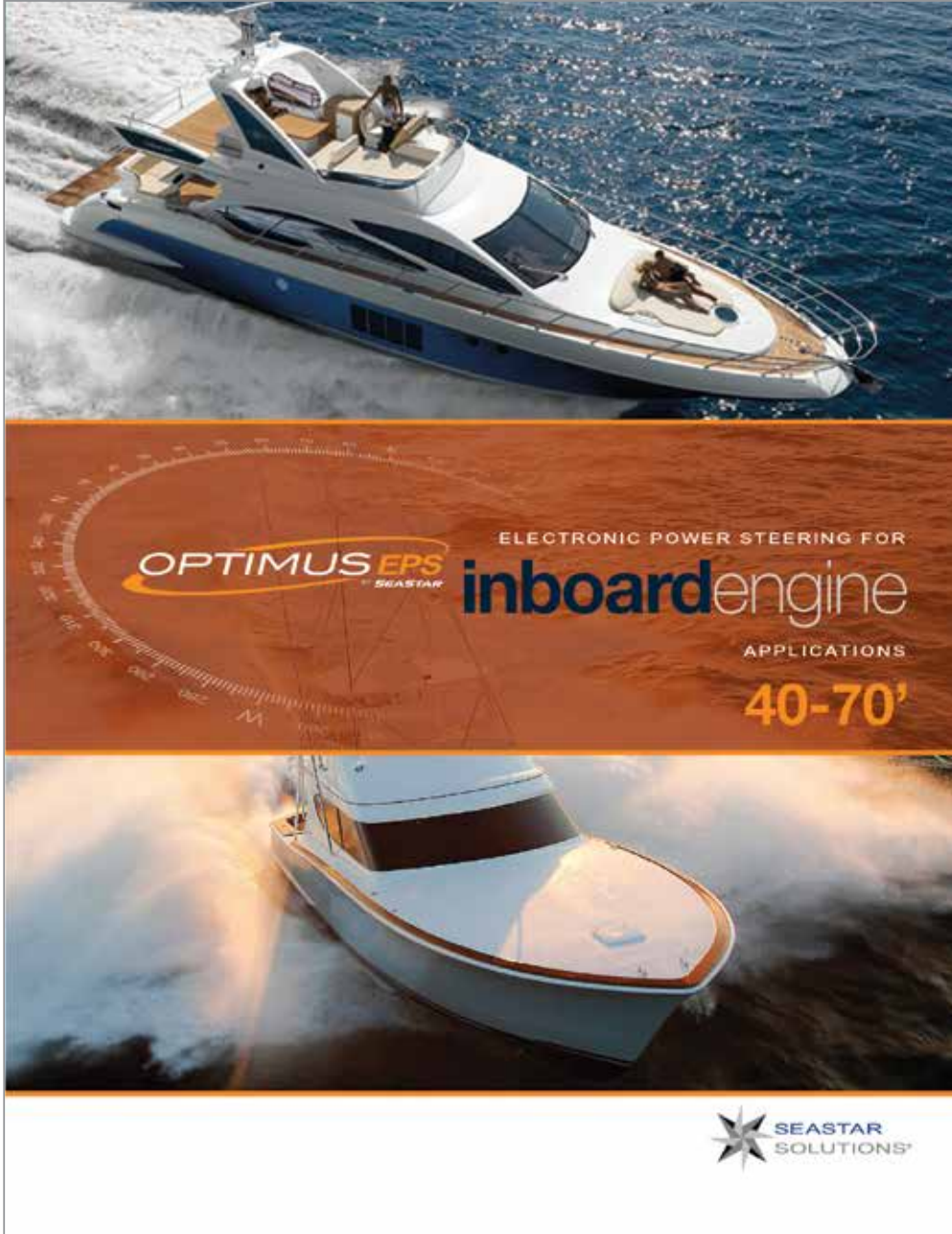

Use our color range
30% black
60% black
Black
Blue
Orange

Identity position 1

Main image

product impact brochure grid

8.5 inches wide x 11 inches deep



product impact brochure spread

4 page example - Templates available ✓

Set up for InDesign 2 and 3 page spreads

Page size 8.5" x 11"

2 column spreads with 0.16" gutter

All margins 0.5"

Titles

Vertical scale 80%

Horizontal 100%

Tracking set to 0

Arial MT Pro Medium - 25pt with 25pt leading or
Helvetica Neue (TT) as shown

Main image

Use quality images only

Branding

OPTIMUS EPS
STERNDRIVE

Available for both retrofit and new engine installations

As the captain of your vessel you know how important it is to have command of your boat. Optimus EPS gives you the steering control, performance and comfort you expect. With Optimus EPS, you can take command of your boat without having to jinn-wrestle for control.

Imagine getting the most steering performance, stability and control from your boat.

Advantages of Optimus Electronic Power Steering

- Auto adjusting speed sensitive helm effort and turns lock to lock
- Low and high speed rudder stop position
- Position proportional rudder gain for faster steering response near neutral rudder position
- Can add autopilot without adding an additional pump
- 2 helm capability
- No more long hydraulic lines run to the helm(s)
- Open loop mode allows system to maintain steering even in the event of a complete loss of RFU signal (single only)
- Unilateral cylinder enables installation in space confined engine compartment
- Comprehensive system status and fault indication
- ISO 2002 Certified. Meets or exceeds ISO, ABYC, CE, ISO and SAE electrical and environmental requirements

Cylinders

- System reliability and operation
- No additional RFU required for autopilot system
- Unilateral cylinder simplifies the installation and allows for easy reinstallation at any time

CANtrak display

- Displays rudder position
- Provides quick and easy system setup interface
- Communicates faults and any special handling instructions to the operator
- Displays system health
- Allows software updating of all system components (USB port on rear)
- Water ingress protection: Up to IP67
- Meets or exceeds ISO, ABYC, CE, ISO and SAE electrical and environmental requirements

inboard

Builds upon the proven Optimus core technology and components, with a new inboard and alternative smart cylinder.

electronic power you can feel

sterndrive

Applications for Optimus EPS

- Most single and twin inboard & sterndrive engine layouts - electronic and mechanical controlled
- Single, twin or triple inboard stern drives
- Competitive on boats, in water, equal towing profile

PCM technology

- Open loop mode allows system to maintain steering in the event of a complete loss of RFU signal (single only)
- Based for easy connection with existing rudders (ISO/CE standard)
- Accommodates 3rd party autopilot systems
- Automatic battery charging and selection
- Water ingress protection: Up to IP67
- Meets or exceeds ISO, ABYC, CE, ISO and SAE electrical and environmental requirements
- CAN bus communications
- Hi-CAN High speed CAN 2.0B (500kps) (SAE J1850)
- Hi-CAN Low speed CAN 2.0A (10kps) (SAE J1850)
- CAN bus Fault tolerant CAN 2.0A (10kps) (SAE J1850)
- Status and fault LEDs

ISO ABYC CE ISO

Use our main color range

30% black

60% black

Black

Blue

Orange

product impact brochure grid

8.5 inches wide x 11 inches deep

Titles

Titles titles

Helvetica Neue - for impact



Examples

Headings

Sub Headings

Body text Arial Regular

Headings

Vertical scale 80%

Horizontal 100%

Tracking set to 0

Arial MT Pro Medium - 16pt with 16pt leading - (preferred)

Arial Bold - 16pt with 16pt leading

Arial Black - 16pt with 16pt leading

Sub Headings

Arial Bold - 12pt with 15pt leading

Body Text

Vertical scale 100%

Horizontal 100%

Tracking set to 0

Arial Regular - 9pt with 15pt leading - (preferred)

Arial MT Pro Medium - 9pt with 15pt leading

Add our complimentary colors

CMYK - Green

C - 33%
M - 10%
Y - 80%



CMYK - Yellow

M - 15%
Y - 65%



CMYK - Blue/Green

C - 81%
M - 53%
Y - 43%
K - 36%



CMYK - Blue

C - 100%
M - 20%
K - 60%



CMYK - Blue/Gray

C - 37%
K - 71%

image placement and quality

Image examples

Here are some example background and life style images. Background images should have plenty of 'clean' area to place text and product images on top.



Quality can be emphasized using images showing products in action



Emphasizing trust in our products

image placement and quality

Uncomplicated images are more powerful and more effective when used with additional graphics and text.

Life style images add 'good feel' to the publications.

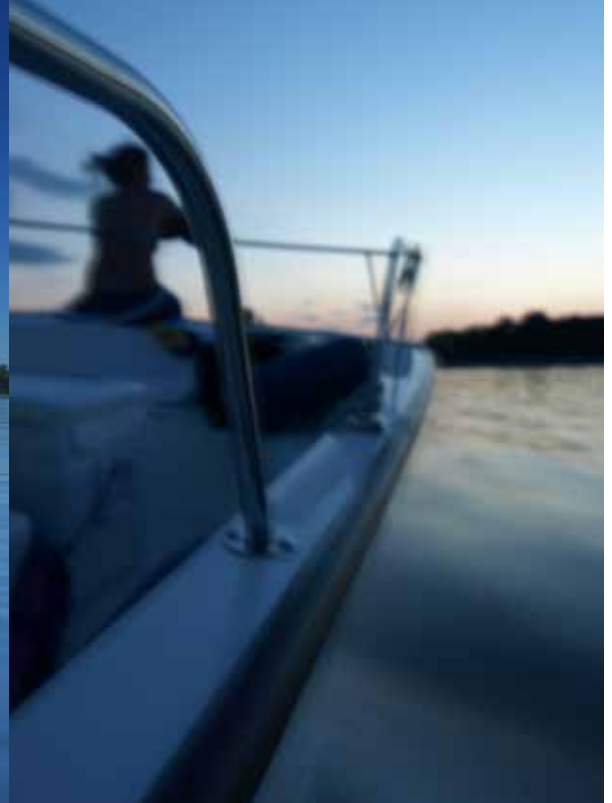

quality standards in reproduction

Notes on reproduction

Reproduction of material can be key to the final result. Maintaining a high standard of quality for product design, artwork and web work has become a priority for companies entering the global market. Competition on the international market means competing against different sets of markers and criteria that vary from nation to nation and region to region. In order to compete on this level, we must adhere to principals of quality to remain highly competitive.

Advertising reproduction

Use these settings for high quality print ready output when producing Acrobat PDF files.

[Based on '[PDF/X-1a:2001]'] Use these settings to create Adobe PDF documents that are to be checked or must conform to PDF/X-1a:2001, an ISO standard for graphic content exchange. For more information on creating PDF/X-1a compliant PDF documents, please refer to the Acrobat User Guide. Created PDF documents can be opened with Acrobat and Adobe Reader 4.0 and later.

▶ see advertisements, for grid layouts p63

quality standards in reproduction

Printed material

Print ready files should have all images set to CMYK 300dpi and color adjusted.

Images should not be reproduced oversized where they become pixilated or out of focus.

Retouch or remove unnecessary objects, wires or unsightly items.

Make horizon lines exactly 'horizontal' if it's meant to be so.

Print Specifications	
4 page color folds to 11 x 8.5"	6 page Tri Fold
120# Gloss Cover	25.375 x 11 – Folds to 8.5 x 11
4 Color Process with Gloss Aqueous	
Print, Score, Fold, Carton Pack	

 [see brochures, for grid layouts p32](#)

corporate letter

Word documents - Templates available ✓

Electronic communications are widely used in place of traditional printed business media.

The image shows a corporate letter template layout with several key dimensions and annotations:

- Header Dimensions:**
 - Width 0.5" (margin)
 - Identity (width)
 - Width 2.68" (main content width)
 - Width 2.75" (margin)
 - Depth 0.85" (logo height)
 - Depth from top 2" (logo vertical position)
- Text Elements:**
 - Star (logo)
 - SEASTAR SOLUTIONS®
 - SeaStar Solutions®
 - 1 Sierra Place
 - Litchfield, IL 62056 USA
 - Phone: 217-324-9430
 - Fax: 217-324-2461
 - Enter date here
 - Enter text here
 - Black (font color)
 - Address
 - Arial Regular 10pt (font)
 - Font color 50% black
 - SeaStar Solutions
 - Font color web safe colors 003366
- Software Panels:**
 - Font Panel:** Shows font settings for 'Arial', 'Regular', size '10'. Includes options for font color (black), underline style, and underline color (Automatic).
 - Paragraph Panel:** Shows 'Indents and Spacing' settings. Alignment is 'Left', Outline Level is 'Body text'. Indentation is 0". Spacing is set to 'Before: 0 pt', 'After: 0 pt', 'Line spacing: Multiple', and 'Multiple: 1.15'.
- Footer Dimensions:**
 - Width 0.5" (margin)
 - Depth 0.7" (margin)
 - Depth 0.5" (logo height)
 - www.seastarsolutions.com

The elements for corporate digital media can be found in our design guideline pack.

corporate electronic stationary

←Width 2.24" →

↑
Depth 2"
↓



MEMO



To:
From:
Date:
Subject:

SeaStar Solutions®
1 Sierra Place
Litchfield, IL 62056 USA
Phone: 217-324-9430
Fax: 217-324-2461

Enter text here



BULLETIN



To:
From:
Date:
Subject:

Enter text here

www

www.seastarsolutions.com

brand letter

Word documents - Templates available ✓

Continuity across brands and businesses

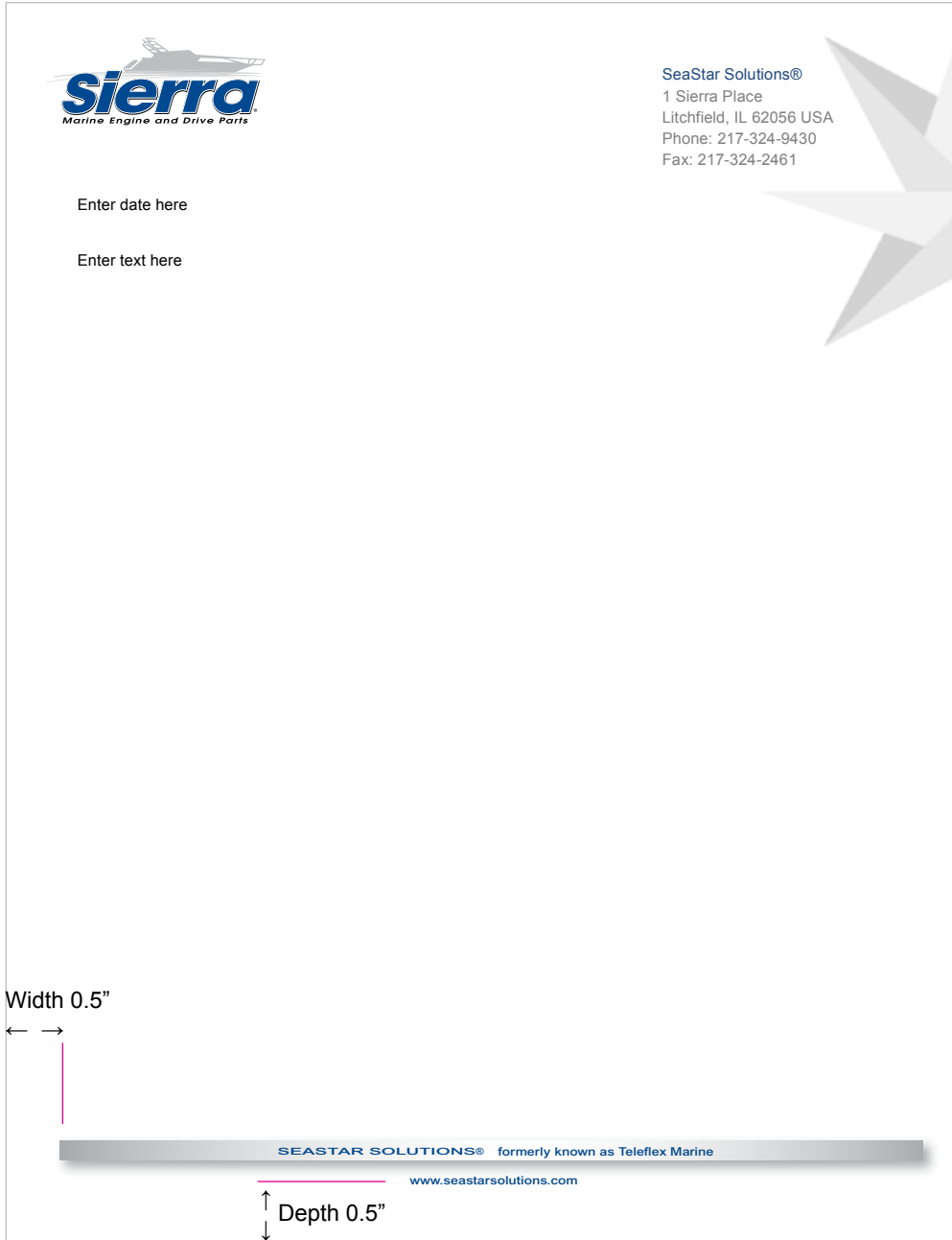

Star

↑
Depth 3.24"
↓

Width 0.5"
Depth 0.7"

Depth 0.5"

The elements for corporate digital media can be found in our design guideline pack.

brand electronic stationary

Electronic media

SEASTAR™

Enter date here

Enter text here



Enter date here

Enter text here

SEASTAR™ **MEMO**

To: SeaStar Solutions®
From: 3831 #6 Road
Date: Richmond
Subject: BC V6V 1P6, Canada
 Phone: 604-270-6899

Enter text here

SEASTAR™ **BULLETIN**

To:
From:
Date:
Subject:

Enter text here



MEMO

To: SeaStar Solutions®
From: 1 Sierra Place
Date: Litchfield, IL 62056 USA
Subject: Phone: 217-324-9430
 Fax: 217-324-2461

Enter text here



BULLETIN

To:
From:
Date:
Subject:

Enter text here

SEASTAR S

other business letters

Word documents

Continuity across brands and businesses

Width 0.5"

←Width 2.75" →

↑
Depth 0.85"
↓

↑
Depth from top 2"
↓



NAPA®
1 Sierra Place
Litchfield, IL 62056 USA
Phone: 217-324-9430
Fax: 217-324-2461

Enter date here

Enter text here

The templates for corporate digital media can be found in our design guideline pack.

other business letters

Templates available ✓



Primeline®
1 Sierra Place
Litchfield, IL 62056 USA
Phone: 217-324-9430
Fax: 217-324-2461

Enter date here

Enter text here



Proheat®
3831 #6 Road
Richmond
BC V6V 1P6, Canada
Phone: 604-270-6899

Enter date here

Enter text here

corporate business cards

Printed business cards



Business cards are often the first point of contact when meeting a new or potential business partner or supplier.

Representing our company with consistent communications across all brands and businesses owned by SeaStar Solutions.

corporate business cards

Templates available ✓

Identity

←Width 2.09" →

Name - Calibri Bold 10pt

Name color

C - 100%

M - 75%

Y - 0%

K - 20%

Address - Calibri Regular 9pt

Font color black



Star

↑
Depth 1.45"
↓

Identity

←Width 1.25" →

brand business cards

Printed business cards



Business cards are often the first point of contact when meeting a new or potential business partner or supplier.

Representing our company with consistent communications across all brands and businesses owned by SeaStar Solutions.

other business cards

Templates available ✓



**POWER EQUIPMENT &
MARINE PRODUCTS**

Walter Rieck

Product Manager
Office 217-324-9473
Mobile 217-851-9023
Fax 217-324-2461
walter.riek@primelinepe.com

1 Sierra Place | Litchfield, IL 62056



Walter Rieck

Product Manager - Power Equipment
Office 217-324-9473
Mobile 217-851-9023
Fax 217-324-2461
walter.riek@primelinepe.com

1 Sierra Place | Litchfield, IL 62056

primelinepe.com



Rick Lawrence

Industrial Product Manager
Office 610-382-1941
Mobile 610-427-9993
Fax 610-569-4230
richard.lawrence@tflexinc.com

640 N. Lewis Rd. | Limerick, PA 19426

primelinecontrols.com



Brian Curliss

Product Manager - Heaters and Military
Mobile 604-270-6899
brian.curliss@proheat.com

3831 No. 6 Road | Richmond, BC V6V 1P6

proheat.com

power point template

Master title slides - Template available

Power Point presentations are used widely across our business promoting new ideas, products, pricing, systems and benefits.

This master Power Point can be tailored for all brands with or without reference to boating but always using the identity as a standard sign off.

We have designed one master to use across all areas.

Easy to use, just select the relevant slides from the master set from within the Power Point file.



Master title and introduction for boating related presentations



Blank Master title and introduction for non boating presentations

power point template

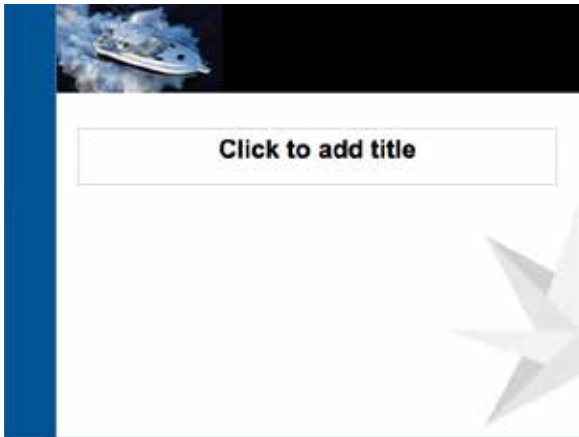

Section title page



Bullet point page Sierra



Bullet point page



Bullet point page Shields



Bullet point page SeaStar - BayStar



Bullet point page Optimus EPS - Optimus 360

data sheets

Grid layout for datasheets
 Template available ✓

Product data sheets are a vital part of our continued quest to provide useful information to customers, engineers and dealers. Simple clean layouts supply technical data in an easy to follow format. Quality images and illustrations only enhance our products global position as some of 'the best in the world'.

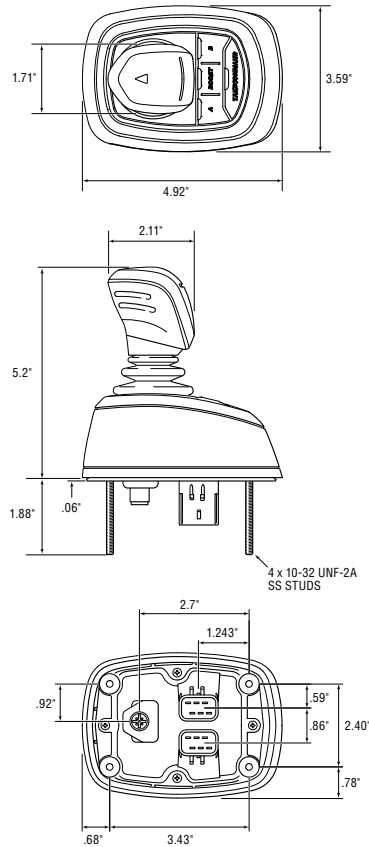

Headings

Vertical scale 80%
 Horizontal 100%
 Tracking set to 0

Arial Bold - 16pt with 16pt leading

Sub Headings

Arial Bold - 12pt with 15pt leading

Body Text

Vertical scale 100%
 Horizontal 100%
 Tracking set to 0

Arial Regular - 9pt with 15pt leading - (preferred)

Graduation rules, chart specifications, identity and social medial links supplied on template.

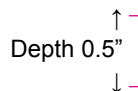

data sheets

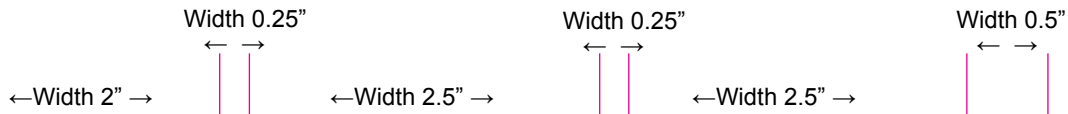

↑ Depth from top 1.21" ↓

↑ Depth 2.59" ↓

↑ Depth 6.1" ↓

↑ Depth 1.1" ↓



OPTIMUS 360 JOYSTICK

Page 1 / 2

APPLICATIONS

- Marine vessel control: Joystick maneuver, bow thruster.
- Industrial multi-axis control: off-highway, mobile equipments, agricultural.

FEATURES

- Rugged electronic 3-axis joystick for 12VDC marine or industrial applications.
- Dual redundant, non-contact hall effort sensors on each axis, sensors total.
- Dual CAN bus outputs: High-speed CAN and fault tolerance CAN.
- Dual redundant, power supplies.
- Design for high-end recreational boats and vehicles.
- Ergonomic handle and base design for comfortable, precision operation.
- Guided feel for preferential primary axis control.
- Flexible base lip seal to fit natural curve of dashboard.
- Soft touch elastomeric four-button keypad with blue LEDs.

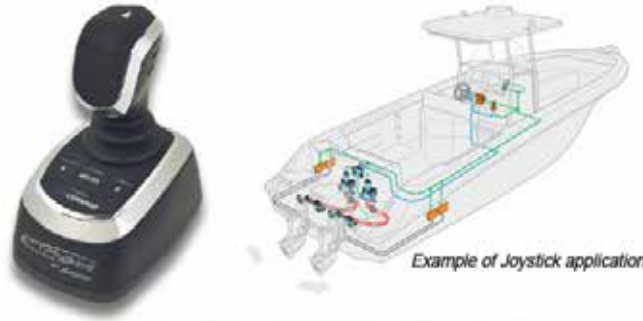

The Optimus 360 Joystick is a non-contact, 3-axis vessel control module providing intelligent position control. It feature dual redundancy for inputs for the most demanding joystick control applications. Specially designed for the marine industry

JOYSTICK SPECIFICATIONS

Electrical

- Operating voltage: 9-16 VDC [SAE J1455]
- Two CAN busses
 - CAN bus 1: High Speed CAN 250 kbps [SAE J1939]
 - CAN bus 2: Fault Tolerance CAN 125 kbps [ISO 11898-3]
- Protected from reverse polarity, power interruption.
- Power transient protection: Switching transient, starter motor disturbance, and load dump. [SAE J1113-11]
- Conducted immunity: 10 Vrms, Criteria A [IEC 60945]
- Radiated immunity: 30 V/m, Criteria A [IEC 60945]
- Electrostatic discharge protection: 6kV contact, 8 kV air [IACS E10]
- Compass safe distance: 50 cm, at 1° deflection [IEC 60945]

Mechanical for X, Y axes

- Mechanical angle of movement: +/- (15° +/- 2°)
- Actuator force: 1.0 +/- 0.2 lbf
- Typical current drawn: Less than 300mA
- Tangential overload limit: 78 lbf [ISO 25197]
- Square limiting plate
- Guided feel for primary X, Y directions
- Durability: Minimum 500,000 cycles

Mechanical for Z axis

- Mechanical angle of movement: +/- (30° +/- 2°)
- Actuator force: 1.0 +/- 0.3 in-lbf
- Rotational overload limit: 8 in-lbf [ISO 25197]

Connection

- 2 x 6-Pin male, FCI Apex-2.8 connectors
- Built in CAN network tee for multi-station connection
- Connector tensile pull resistance: 60 lbf [ISO 10133]

Issue Date - March 2013
Issue Number - eps2



www.seastarsolutions.com



SEASTAR SOLUTIONS
WORLD LEADER IN MARINE SOLUTIONS
THINK GLOBAL. THINK SEASTAR SOLUTIONS.

technical manuals

Technical manual design

Technical manuals are available on the www.seastarsolutions.com web site. Technical manuals are produced by the factory of manufacture only. No attempt to copy or reproduce these manuals are permitted. No templates are available.

MEMBER
ABYC
Setting Standards for Safer Boating

51

FIFTY ONE
ISO 9001

OPTIMUS EPS
BY SEASTAR

BAYSTAR™

SEASTAR™

OPERATION INSTRUCTIONS

AND USER'S MANUAL

www.seastarsolutions.com





Electronic Power Steering for
Outboard Powered Vessels



SEASTAR
SOLUTIONS®

Before you do it your way,
please try it our way

press releases

Templates available ✓

Press releases are a vital part of our communications allowing our business to publish vital and current information as it happens. All press releases can be found on www.seastarsolutions.com



Press Release

For Immediate Release
 Contact: Rick Hauser
 (805) 427-5259 or rickhauser@rickhausergroup.com

TELEFLEX MARINE ANNOUNCES NAME CHANGE TO SEASTAR SOLUTIONS

**New Name Reflects Company's Commitment To Performance, Quality and Innovation
 In The Global Marine Market**

(February 14, 2013 – Litchfield, Ill) Teleflex Marine, the leading manufacturer and distributor of marine control systems, engine and drive components and other products for the OEM and aftermarket marine trade, today announced that it is changing its name to SeaStar Solutions.

The name change comes two years after Teleflex Marine was acquired by H.I.G. Capital. "This change represents more than just a new name," said Yvan Cote, CEO of the new SeaStar Solutions. "SeaStar connects us with our brand heritage, to be sure, but the new name goes further with an inherent promise to provide the marine market with the very best in products, services and innovation. We want to make the boating experience more enjoyable for everyone."



The company's new focus is already yielding impressive results. In 2012, SeaStar Solutions introduced two NMMA Innovation Award-winning products, the Optimus 360 Joystick Control System and Xtreme Mechanical Steering System. "New product innovation is a part of our DNA," said Cote. "Being on our own feels like starting a new company. We're now able to create new and better ways to serve our customers and enhance the boater's experience on the water. You can expect that drive to continue as we move forward," he added. The recent acquisition of Detwiler Jack Plates has also proven successful and the company is working on additional acquisitions to fuel growth.

The new logo design is built around a compass rose that fits well with the company's marine heritage. "Our new logo points the way to an exciting future for our company, our employees and for our customers," added Cote.

Transition to the new name, including rebranding of products and changes to packaging and marketing materials, will take place over the next 12 months. SeaStar Solutions has planned extensive outreach programs to their employees, customers and vendors to help chart the course to their new identity.

The templates for corporate digital media can be found in our design guideline pack.

dealer electronic promotions

e-blasts



E-Blasts and electronic media are a strong part of company marketing reaching to many customers, dealers and distributors via direct contact with bespoke messages.

We update the design for e-blast media each year and will therefore update these guidelines to include the changes.

OnBoard Rewards program logo for Dealer specific promotions. Only use in this color format.

Use a 1pt white keyline for dark backgrounds.

Headings
Arial MT Pro caps
Set vertical scale to 80%

Text
Arial Regular

dealernetworknews
Issue 92 February 2013



SIERRA SPLINE GREASE

Sierra offers high quality marine grade spline grease.



SEASTAR SOLUTIONS®

Features/Benefits

- High quality specialty grease for yolks and engine couplers.
- Supreme protection from heat, rust and corrosion.
- Formulated for high operating pressures at varying temperatures.
- Ultimate water resistant formula.
- Backed by our industry leading warranty.
- Sierra #18-9200 replaces Mercury 92-81639A4

LEARN MORE ABOUT SIERRA GREASE ▶

Visit SeaStar Solutions | Login Dealer Network | Contact Us

other electronic promotions

Web banners - rotating gifs



Web banners are a great way to promote a strong message.
Simple, straight to the point web banners can be very effective.

Users browse in different ways, some click only on information they are looking for and some surf via information that catches their eye.

Users generally notice web banners. Eye-tracking tests and other means provide information on how users perceived a single web page and what they could recognize and recall of it afterwards.

product advertising

Advertising guidelines - Template available ✓

Sierra
Marine Engine and Drive Parts

**START WITH
SIERRA STARTERS
& ALTERNATORS**

ALTERNATORS

STARTERS

Sierra specializes in the most comprehensive range of starters and alternators. Sierra offers an extensive selection of over 400 Rotating Electrical products including starters, alternators, trim motors, solenoids, rectifiers and relays. All products are backed by Sierra's industry leading warranty!

Learn more

**SEASTAR
SOLUTIONS®**

www.seastarsolutions.com

Product advertising must have a simple strong message combined with quality photography, illustrations or electronically generated media. Strong background color to enhance the product is encouraged but must not be abused such as florescent colors.

Main titles - Arial MT Pro Medium

set vertical scale 80%

or

YOKO

Use either typeface its own or

both as shown

Headings

Vertical scale 80%

Horizontal 100%

Tracking set to 0

Arial Bold - 16pt with 16pt leading

Sub Headings

Arial Bold - 12pt with 15pt leading

Body Text

Vertical scale 100%

Horizontal 100%

Tracking set to 0

Arial Regular - 9pt with 15pt leading - (go up in increments where space allows)

corporate advertising

Corporate advertising is based on 1 background image with 1 main heading and sign off text.

Quality imagery follows the same criteria as product advertising.



NEW NAME, BRIGHT FUTURE

 **SEASTAR**
SOLUTIONS®

- * Innovative new products
- * Advanced technology
- * OEM preference
- * Extensive product coverage
- * 65 year heritage
- * Infinite possibilities

 **SEASTAR**
SOLUTIONS®

The new SeaStar Solutions 'Star' will provide energy and core strength to support its brands and products.

www.seastarsolutions.com

exhibition graphics

Graphic guidelines - Template available ✓

go xtreme

controls

mechanical

steering

cables

controls

Single top mount provide ergonomics and features that are the most advanced available. They are suitable for most types of boats with single engine applications. The shapely, balanced handle provides a very comfortable feel and the state of the art mechanism guarantees a smooth yet solid action, assuring you have maximum control at all times.

Dual top mount, unique options for top mount controls, including trim (most outboards) or trim and tilt (most stern drives) or the neutral lock out button. Designed for twin engine applications and suitable for use with both universal type (3300) or OEM type control cables without the need for adaptation.

mechanical

Side mount

- Built upon proven Osprey design with modern ergonomics, based on hands size variations
- Neutral lifter replaces push button
- Trim switch moved to a natural location
- Same mechanical advantage
- Robust control concept

steering

The XTREME™ Mechanical Steering System brings a new level of smooth, effortless handling and precision control to an important class of boats.

cables

Designed for complex and/or long cable runs (or to simply create a superior feel).

Simply the best cable in the business.

Main Titles

Helvetica Neue (TT) Bold

Body Text

Helvetica Neue (TT) Regular Vertical height 80%

Exhibition graphics are generally viewed from a distance to attract attention.

Detail can be added for discussion points and should not overpower or interfere with the main message.

SeaStar

Main titles - Helvetica Neue (TT) Bold Vertical height 80% V/A -30

exhibition graphics

The Style of graphics will change approximately every 2 years.
These guidelines will be updated accordingly.



Main Titles

Helvetica Neue (TT) Bold

Body Text

Helvetica Neue (TT) Thin

20' Panel



Hydraulic

consumer view

3

The following section covers grid layouts and guidelines for art workers and printers. To continue the uniform look across literature, stationary and corporate items the following section brings styling for packaging, dealers web and digital media.

Global window

The screenshot displays the Seastar Solutions website interface. At the top, the navigation bar includes links for Home, Products, SONAR, Support, Contact Us, Marketing, Global Locator, and Blog. A search bar is positioned to the right of the navigation. The main content area features a large banner for the "OnBoard Rewards ready to go" program, with a man in a blue uniform and a circular logo. Below the banner are four promotional tiles: "Sierra Marine Parts Catalog 2016", "SEASTAR JACKPLATE", "Come see us at MIAMI BOAT SHOW", and "2016 MIAMI BOAT SHOW OPTIMUS 360". The footer contains links for Distributor Login, Custom Solutions, Privacy Policy, Terms, Boating Safety, About Us, Sitemap, and California Transparency Act. Copyright information for Seastar Solutions is also present.

layouts and grids

Creating recognition to consumer and dealers

Product overview



Product impact

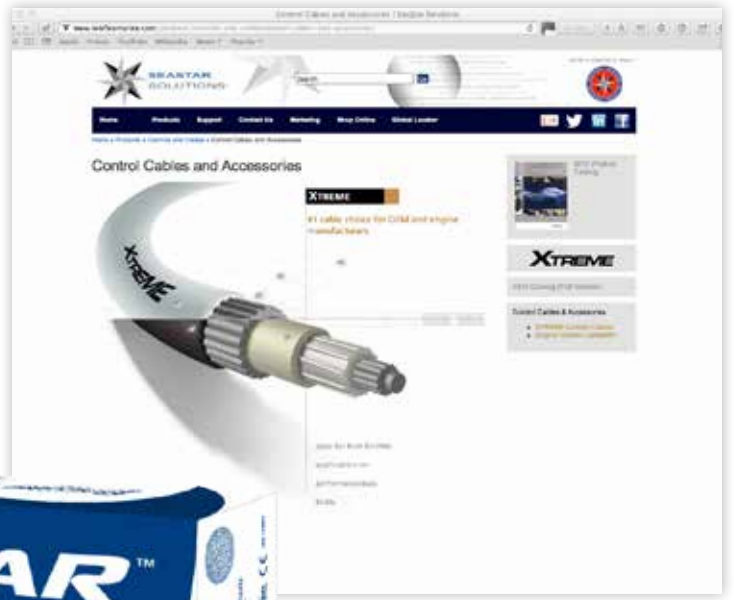

Packaging



packaging



Some examples of packaging using the globe logo to its best advantage. Printed in single color Pantone 280.

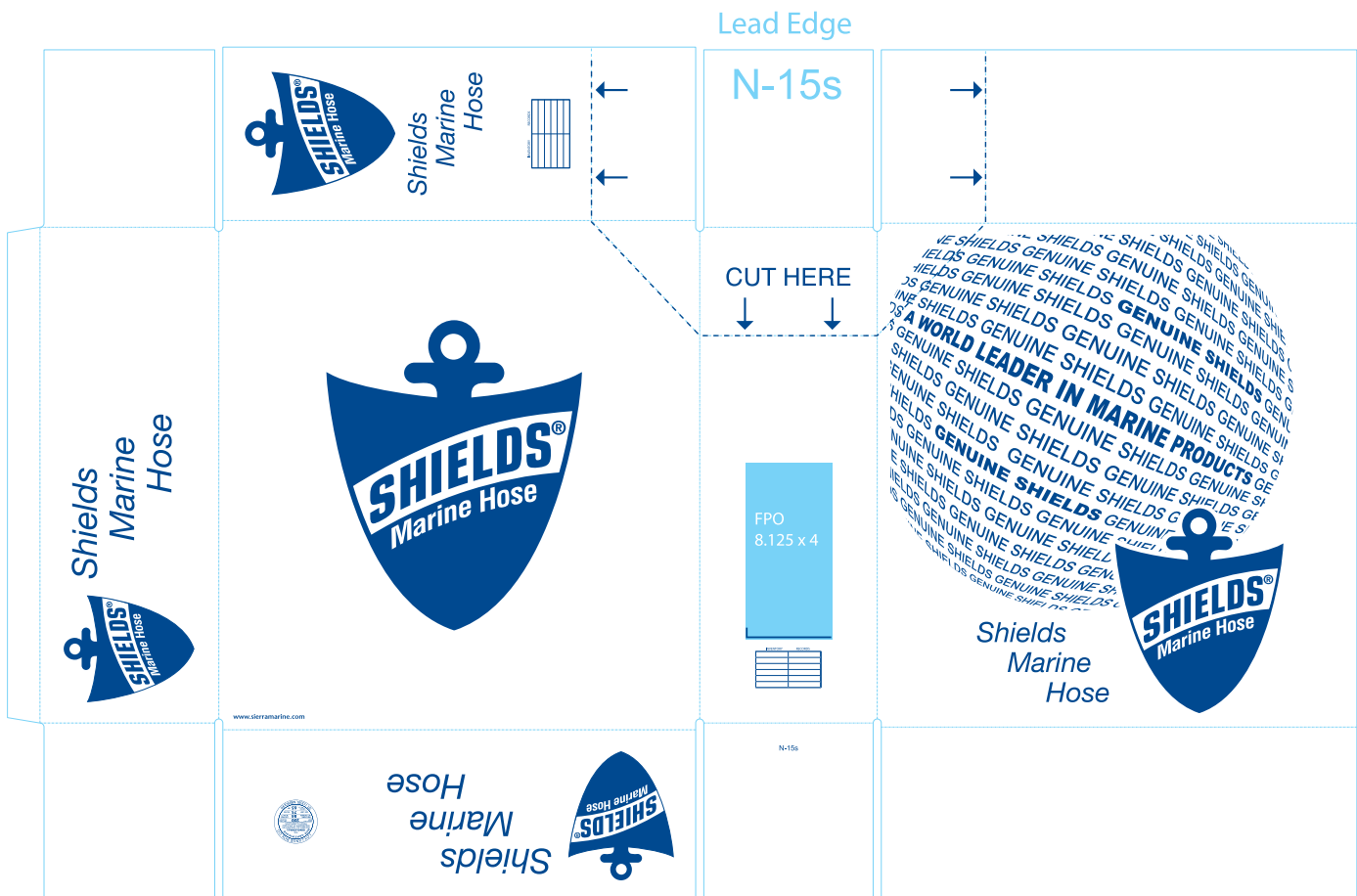

product endorsement

Creating recognition to consumer and dealers

18-7945
Sierra
Marine Engine and Drive Parts
High Performance Fuel/Water Separating Filter
90 GPH / 10 MICRON FILTRATION — OVER 90% EFFICIENCY FOR ALL MARINE ENGINES INCLUDING HIGH TECH DIESEL ENGINES

REPLACES:
Mercury 35-80283Q
Yamaha A8A-FUEZ-F-R-TR
A8B-FUEZ-F-R-TR

10 MICRON BEST FILTRATION

18-7945
Sierra
Marine Engine and Drive Parts
High Performance Fuel/Water Separating Filter
90 GPH / 10 MICRON FILTRATION — OVER 90% EFFICIENCY FOR ALL MARINE ENGINES INCLUDING HIGH TECH DIESEL ENGINES

REPLACES:
Mercury 35-80283Q
Yamaha A8A-FUEZ-F-R-TR
A8B-FUEZ-F-R-TR

10 MICRON BEST FILTRATION

18-7945

WARNING: FUEL SYSTEM PRESSURIZED — RIEGAZADO

- FILTER SHOULD BE CHANGED BY A TRAINED MECHANIC.
- FOLLOW MANUFACTURER'S INSTRUCTIONS.
- RELEASE FUEL SYSTEM PRESSURE BEFORE SERVICING.

AVERTISSEMENT: SYSTÈME DE CARBURANT SOUS PRESSION: FUIRGE D'ENRAGE

- LE FILTRE DEVRAIT ÊTRE REMPLACÉ PAR UN MÉCANICIEN FORMÉ.
- SUIVEZ LES INSTRUCTIONS DU FABRICANT AVANT DE FAIRE L'ENTRETIEN.

ADVERTENCIA: SISTEMA DE COMBUSTIBLE PRESURIZADO — PELIGRO DE INCENDIO

- EL FILTRO SIEMPRE DEBE CAMBIADO POR UN MECÁNICO ENTRENADO.
- LEA LAS INSTRUCCIONES DEL FABRICANTE.
- ALIVIA LA PRESIÓN DEL SISTEMA DE COMBUSTIBLE ANTES DE OMBRIR SERVICIOS.

Part No. 18-7945

Sierra International
Litchfield, IL 62556
Made in Taiwan
www.sierramarine.com

18-7945
Sierra
Marine Engine and Drive Parts
High Performance Fuel/Water Separating Filter
90 GPH / 10 MICRON FILTRATION — OVER 90% EFFICIENCY FOR ALL MARINE ENGINES INCLUDING HIGH TECH DIESEL ENGINES

REPLACES:
Mercury 35-80283Q
Yamaha A8A-FUEZ-F-R-TR
A8B-FUEZ-F-R-TR

10 MICRON BEST FILTRATION

18-7824-1
Sierra
Marine Engine and Drive Parts
Premium Marine Oil Filter

REPLACES:
CruiserCraft 16-81-08746
Cruiser 201104
Mercury 35-80283SQ / 35-866340K01
OMC 50292
Plasseraert 8077002
Vdo 835465-9
Yamaha YSC-13231-20-OC

18-7824-1
Sierra
Marine Engine and Drive Parts
Premium Marine Oil Filter

REPLACES:
CruiserCraft 16-81-08746
Cruiser 201104
Mercury 35-80283SQ / 35-866340K01
OMC 50292
Plasseraert 8077002
Vdo 835465-9
Yamaha YSC-13231-20-OC

18-7824-1

- MEETS OR EXCEEDS OEM MANUFACTURERS' SPECIFICATIONS.
- ANTI-DRAINBACK VALVE TO PREVENT DRY STARTS (WHERE APPLICABLE).
- HIGH-EFFICIENCY FINE MEDIA FOR EXCELLENT ENGINE PROTECTION.

RESPECTE OU EXCÈDE LES SPÉCIFICATIONS DU FABRICANT DE L'ÉQUIPEMENT D'ORIGINE (OEM)

- Système anti-retour pour éviter les démarrages à sec (où cela s'applique).
- Système à filtre de haute efficacité pour une excellente protection du moteur.

ESTÁ DE ACUERDO O EXCEDE LAS ESPECIFICACIONES DEL FABRICANTE OEM.

- VALVULA ANTI-RETORNO PARA EVITAR ARRANCADAS EN SECO (DONDE APLICABLE).
- MEDIA DE FILTRACION DE ALTA EFICIENCIA PARA EXCELENTE PROTECCION DEL MOTOR.

Part No. 18-7824-1

Sierra International
Litchfield, IL 62556
Made in Taiwan
www.sierramarine.com

18-7824-1
Sierra
Marine Engine and Drive Parts
Premium Marine Oil Filter

REPLACES:
CruiserCraft 16-81-08746
Cruiser 201104
Mercury 35-80283SQ / 35-866340K01
OMC 50292
Plasseraert 8077002
Vdo 835465-9
Yamaha YSC-13231-20-OC

MADE IN TAIWAN

displays and Point of Sale



Dealers will benefit from display and point of sale material in many ways. All kinds of promotional elements at the point of sale, are versatile and appealing, generate flow towards your message, company and products, raise awareness of your campaign's aim, quickly, directly and with impact.

signage

Attitudes can develop without being aware of its antecedents.

Subliminal visual stimuli evokes emotion without being aware.

We aim to reassure our dealers and customers with marketing support material which gently stimulates long term loyalty.

Banner artwork - Template available ✓



web site



Home Products SONAR Support Contact Us Marketing Global Locator Blog

Outboard Steering

Hydraulic Outboard Steering Systems





Outboard Single engines - Twins - Auxiliary - Triples and Quads

Installation Manuals
Service Parts
Important Notices
Technical Support

BAYSTAR™

BayStar Outboard Steering

Overview

With mechanical steering you sacrifice a degree of comfort, and traditional hydraulic systems may be more than is needed on lower horsepower engines. The solution is finally here—BayStar!

Built in the tradition of the industry leading hydraulic steering, SeaStar, BayStar brings the same safety and comfort now common on larger outboard powered boats to outboard powered boats with a maximum 150 HP (total) or less.

SEASTAR™

SeaStar Outboard Steering

SeaStar outboard hydraulic steering offers a very extensive range of engine and steering system alternatives. This guide will assist you in the selection of the steering system best suited to your boat.

Selecting the Outboard Steering System best suited for your boat:

1. Locate the type of boat you have in column A of the chart below.
2. From the chart, select the steering system best suited to your boat. You may want to review the specific features for each system.
3. Select from links on the right for a detailed component selection.

Front Mount System, Side Mount System or Splashwell Mount System.

Boat Description	Front Mount System		Side Mount System		Splashwell Mount System		Key
Column A	Single	Twin	Single	Twin	Single	Twin	
Center Console*	A	A	B	B	B	B	A: Best Application B: Good Application N/A: Not Applicable
Cruiser*	A	A	B	B	B	B	
Fish "N" Ski*	A	N/A	B	B	N/A	N/A	
Other Fish Boat*	A	A	B	B	B	B	
Runabout*	A	A	N/A	N/A	N/A	N/A	
Bass Boat*	A	N/A	N/A	N/A	N/A	N/A	
Inflatables*	A	B	N/A	N/A	B	B	
Work/Commercial/Rescue*	A	A	B	B	B	B	

SeaStar Tie Bars Catalog 2015



2015 Hydraulic Steering Selection Guide



Outboard Steering

- BayStar Outboard
- SeaStar Kicker Cable Tie Bar
- SeaStar (Front Mount)
- SeaStar (Catamaran)
- SeaStar (Side Mount)
- SeaStar (Splashwell Mount)
- SeaStar Pro Outboard
- SeaStar Smartstick
- SeaStar Tournament

Hydraulic Steering

- Outboard Steering
- Inboard Steering
- Sterndrive Steering
- Inboard Power Steering
- Power Assisted Steering
- Helms
- Fittings
- Hydraulic Fluids
- Hose and Tube

Outboard Hydraulic Steering Video



Replacement Parts

SeaStar Hydraulic Steering - How It Works

Boating Safety

social media

Our web site is our window to the world. Simple layout ensures customers can find product information, services and support quickly and easily.

Dealers can use marketing information and are constantly engaged with new products, Dealer support and Dealer rewards.

Customers can ask questions on products, get technical support and advice and search our global dealer network for local services.

Social media refers to the means of interactions among people in which they create, share, and exchange information and ideas in virtual communities and networks allowing the creation and exchange of user-generated content. Furthermore, social media depend on mobile and web-based technologies to create highly interactive platforms through which individuals and communities share, co-create, discuss, and modify user-generated content. It introduces substantial and pervasive changes to communication between organizations, communities and individuals.

Social media differentiates from traditional/industrial media in many aspects such as quality, reach, frequency, usability, immediacy and permanence. Internet users continue to spend more time with social media sites than any other type of site.



Twitter



Facebook

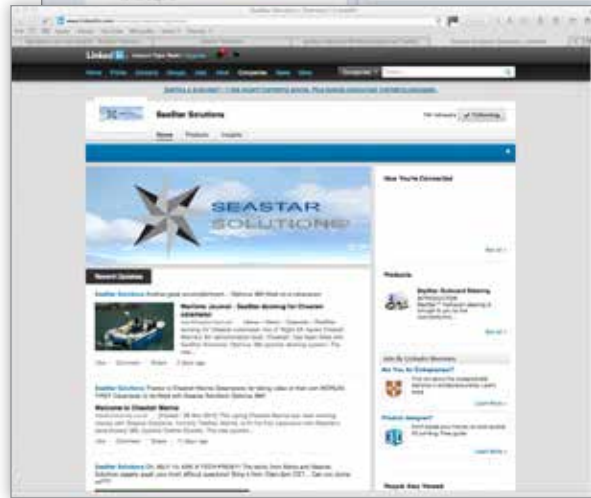

Linked In

clothing and gifting, sales tools



Product specific web site



sales tools

Our sales team will benefit from well presented printed material when demonstrating new products to the dealers.



Packaging Brochure Exhibition stand



international size templates

International size templates are available for the following items.

Word letters

Business cards

Power point - Template as North America

Standard product brochure

Impact brochure

Data sheets

Press releases

Electronic media - Template as North America

Advertising

Exhibition graphics

international examples

Subtle changes are required for adjustment to A4 size, please use the international templates provided.



technical glossary

Our Identity

To facilitate communication with suppliers, this page includes a number of industry terms which you may come across:

SeaStar Solutions® - The company name (identity).

Identity - The company name as seen in a consistent format and color.

CMYK - Initials for the four process colors of cyan, magenta, yellow and black inks used in full color printing. The combination of these colors creates a broad range of colors and hues.

Pantone™ Matching System (PMS) - The proprietary color ink system from Pantone, Inc., that is commonly referred to as Special Color or Spot Color.

technical glossary

For Designers

Artwork - (A/W) Illustrations, diagrams, line art and photographs prepared for reproduction. Also called Finished Art or F/A.

Color Proofs - A preliminary color output to show what the final item will look like.

Color Separations - (Color Seps) In color reproduction, the process of separating the colors of an image, by means of a scanner or process camera, into a form suitable for printing.

Resolution, DPI & LPI In reproduction, - the resolution at which an image or transparency is scanned and the output resolution finally determines the fineness of the final printed image. The higher the resolution, the finer the printed image. The terms DPI and LPI are related to resolution.

Dots-per-inch (dpi) - is the number of dots or pixels displayed per inch which determines the resolution of an image. A higher number of pixels per inch gives a higher resolution.

Line-per-inch (lpi) - indicates the screen density (resolution) at which the item is to be printed. Example: Newspapers are printed at 85 lpi (coarse) while a four color printed brochure is usually printed at 150 to 175 lpi (fine).

Point size - When you come across specifications for typeface setting, for example “55 Helvetica Roman 8/9.5pt”, the numbers refer to the point size (size of lettering) and the leading (the space between lines of leading) - 8pt text set on 9.5pt leading. This is the industry standard way of indicating type dimensions and setting.

Vinyl Films - The range of materials used on signage surface applications. These vary in permanence and are available for different purposes, including building windows (in order to let light in), reflective for impact at night.

Typography tracking - In typography, letter-spacing, usually called tracking by typographers, refers to a consistent degree of increase (or sometimes decrease) of space between letters to affect density in a line or block of text.

Horizontal/Vertical scale - Horizontal scale and vertical scale specify the proportion between the height and width of the type relative to the baseline. You can adjust scale to compress or expand selected characters in both width and height.

Scaling type using a transformation tool affects the type's horizontal scale as well as the type size, leading, indentation, and baseline shift. When type has been scaled using a transformation tool, you can revert it to its original horizontal scale by setting the horizontal scale to 100%.

Note: Depending on the value you enter when you use vertical type, the horizontal scale may make the text appear narrower, because it functions relative to the baseline. The opposite is true for vertical scale.

To adjust the horizontal or vertical scale of type:

Select any type container or type path using a selection tool, or select a range of text using the type tools.

If the Horizontal Scale pop-up menu and the Vertical Scale pop-up menu are not visible in the Character palette, choose Show Options from the Character menu.

Enter a percentage in the Horizontal Scale or the Vertical Scale text box.