

MEMBER  
**ABYC**  
Setting Standards for Safer Boating

50

FIFTY  
ISO 9001

OPTIMUS EPS  
BY SEASTAR

**BAYSTAR**<sup>™</sup>

**SEASTAR**<sup>™</sup>

# INSTALLATION MANUAL

## ELECTRONIC POWER STEERING (EPS)

[www.seastarsolutions.com](http://www.seastarsolutions.com)

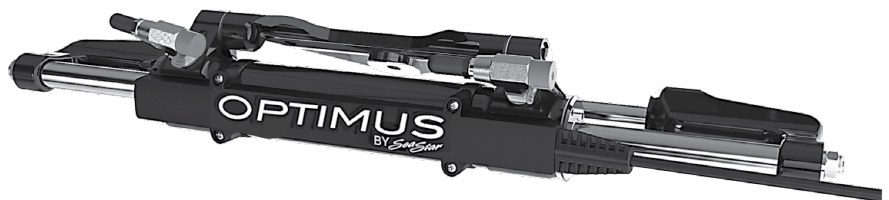

**OPTIMUS EPS**  
BY SEASTAR

---

Electronic Power Steering for  
Outboard Powered Vessels

---



*Before you do it your way,  
please try it our way*

**©2014 SeaStar Solutions.**

All Rights Reserved. This document, subject matter and all information herein is the sole, exclusive and confidential property of SeaStar Solutions and shall not be disclosed, copied, reproduced or used in whole or in part for any purpose other than as specifically authorized in writing by Marine Canada Acquisition (DBA SEASTAR SOLUTIONS).

---

All information, illustrations and specifications in this manual are based on the latest information available at the time of publishing. The illustrations used in this manual are intended as representative reference views only. Moreover, because of our continuous product improvement policy, we may modify information, illustrations and/or specifications to explain and/or exemplify a product, service or maintenance improvement. We reserve the right to make any change at any time without notice.



is a registered trademark of the American Boat & Yacht Council (<http://www.abycinc.org>)

NMEA 2000® is a registered trademark of the National Marine Electronics Association.

Optimus, Optimus 360, SeaStar, and BayStar are all trademarks of SeaStar Solutions.

---

**California  
Proposition 65 Warning**

Battery posts, terminals, and related accessories contain lead and lead compounds, chemicals known to the state of California to cause cancer and reproductive harm.

Wash hands after handling.

Thank you for choosing an Optimus™ Electronic Power Steering (EPS) System. You have chosen a state of the art steering system that will provide years of effortless and trouble free steering performance.

## About this Book

---

This book contains the information required to install and calibrate the Optimus EPS System.

It is to be delivered to the customer when installation is complete.

## Notice to the Installer

---

Throughout this publication, Dangers, Warnings and Cautions (accompanied by the International Hazard Symbol ) are used to alert the user to special instructions concerning a particular service or operation that may be hazardous if ignored or performed incorrectly or carelessly. **Observe Them Carefully!**

These safety alerts alone cannot eliminate the hazards that they signal. Strict compliance with these special instructions during installation, operation, and maintenance, plus common sense operation, are important measures to prevent accidents.

---

### DANGER

**IMMEDIATE HAZARDS WHICH, IF NOT ACTED UPON, WILL RESULT IN SEVERE PERSONAL INJURY OR DEATH.**

### WARNING

**HAZARDS OR UNSAFE PRACTICES WHICH, IF NOT ACTED UPON, COULD RESULT IN SEVERE PERSONAL INJURY OR DEATH.**

### CAUTION

**Hazards or unsafe practices which COULD result in minor injury or product or property damage.**

### NOTICE

*Information which is important to proper use or maintenance, but is not hazard-related.*

*This page left intentionally blank.*

# INDEX

<b>Abbreviations .....</b>	<b>viii</b>
<b>1.0 Safety Information .....</b>	<b>1-1</b>
1.1 Safety Labels .....	1-3
<b>2.0 System Overview .....</b>	<b>2-1</b>
2.1 System Description .....	2-1
2.2 Optimus EPS System Diagrams .....	2-3
<b>3.0 Installation Overview .....</b>	<b>3-1</b>
3.1 Important Information/Technical Support Contact.....	3-1
3.2 Installation Summary.....	3-1
<b>4.0 Planning.....</b>	<b>4-1</b>
4.1 Planning .....	4-1
4.2 Required Parts .....	4-2
4.3 Plan Your Component Placement .....	4-3
4.3.1 <i>Electronic Helm(s)</i> .....	4-3
4.3.2 <i>CANtrak Display</i> .....	4-5
4.3.3 <i>Pump Control Module (PCM)</i> .....	4-8
4.3.4 <i>Power steering pump</i> .....	4-10
4.3.5 <i>SmartCylinders</i> .....	4-11
4.3.6 <i>Steering Service Valves</i> .....	4-12
4.3.7 <i>Circuit Breakers</i> .....	4-12
4.4 Plan Your Connections .....	4-13
4.4.1 <i>Hydraulic Hoses</i> .....	4-13
4.4.2 <i>Power Connections</i> .....	4-15
4.4.3 <i>Ignition &amp; Tachometer Connections</i> .....	4-19
4.4.4 <i>Optional Autopilot Connection</i> .....	4-19
4.5 Diagram.....	4-20
<b>5.0 Installation.....</b>	<b>5-1</b>
5.1 Mounting the Helm(s).....	5-1
5.1.1 <i>EPS Front Mount Helm (EH1510)</i> .....	5-2
5.1.2 <i>EPS Sport Plus Tilt Helm (EH1530)</i> .....	5-3
5.1.3 <i>EPS Classic Tilt Helm (EH1550)</i> .....	5-4
5.1.4 <i>EPS Rear Mount Helm (EH1570)</i> .....	5-5
5.2 CANtrak Display .....	5-6
5.3 PCM and Power Steering Pumps .....	5-7
5.3.1 <i>PCM Recommended Mount Hardware</i> .....	5-7
5.3.2 <i>PCM Mounting Considerations</i> .....	5-8
5.3.3 <i>Power Steering Pump Mounting Considerations</i> ....	5-9
5.3.4 <i>Integrated Steering Service Valve</i> .....	5-11
5.3.5 <i>Power Steering Pump Mounting Hardware</i> .....	5-11
5.4 SmartCylinder Mounting.....	5-12
5.4.1 <i>Ground Strap Installation</i> .....	5-17
5.5 Plumbing the System .....	5-18
5.5.1 <i>Hose Labels</i> .....	5-19
5.5.2 <i>Hose Installation</i> .....	5-20
5.5.3 <i>Hose Fitting Reorientation (if required)</i> .....	5-22
5.7 Connecting the SmartCylinder .....	5-24

<b>6.0 Networks and Wiring .....</b>	<b>6-1</b>
6.1 Network Diagrams .....	6-1
6.2 Harness Connections .....	6-3
6.2.1 <i>Connecting the Helm</i> .....	6-3
6.2.2 <i>Connecting a Second Station</i> .....	6-5
6.2.3 <i>Connecting the CANtrak</i> .....	6-6
6.3 Power Wiring .....	6-7
6.3.1 <i>PCM Wiring</i> .....	6-7
6.3.2 <i>PCM Wiring Strain Relief</i> .....	6-7
6.4 Ignition Sensing .....	6-8
6.4.1 <i>Ignition Splicing</i> .....	6-9
6.5 Engine RPM Source .....	6-10
6.5.1 <i>NMEA 2000 CAN Bus</i> .....	6-10
6.5.2 <i>Analog Tachometer</i> .....	6-13
6.6 Autopilot Connection (Optional) .....	6-13
6.7 Buzzer Kit (Optional) .....	6-14
<b>7.0 Setup, Purging, and Calibration .....</b>	<b>7-1</b>
7.1 Initial System Setup .....	7-1
7.2 Purging the Steering System .....	7-4
7.2.1 <i>Preparation</i> .....	7-4
7.2.2 <i>The Purging Process</i> .....	7-5
7.3 Calibrating the SmartCylinders .....	7-8
7.3.1 <i>Restricting SmartCylinder Travel</i> .....	7-9
7.4 Steering Settings .....	7-11
7.4.1 <i>Adjustment</i> .....	7-12
7.4.2 <i>Available Settings</i> .....	7-13
7.4.3 <i>User Permissions</i> .....	7-14
<b>8.0 Commissioning .....</b>	<b>8-1</b>
8.1 Installation Checks .....	8-1
8.2 Pre-trip Checks .....	8-3
8.3 Sea Trial .....	8-5
8.3.1 <i>Verify Tachometer Signal</i> .....	8-5
8.3.2 <i>Check Steering Performance</i> .....	8-5
8.3.3 <i>Steering Adjustments</i> .....	8-6
8.3.4 <i>Conclusion of Sea Trial</i> .....	8-6
8.4 Complete Warranty Checklist .....	8-6
<b>9.0 Fault Handling .....</b>	<b>9-1</b>
9.1 <i>Danger Fault Handling</i> .....	9-1
9.2 <i>Warning Fault Handling</i> .....	9-2
<b>10.0 Warranty .....</b>	<b>10-1</b>
10.1 Statement of Limited Warranty .....	10-1
10.2 Return Goods Procedure .....	10-1
<b>Appendix A – Mounting Templates .....</b>	<b>A-1</b>
A.1 Helm Templates .....	A-1
A.1.1 <i>Front Mount Helm</i> .....	A-1
A.1.2 <i>Rear Mount Helm</i> .....	A-3
A.1.3 <i>Classic Tilt Helm</i> .....	A-5
A.1.4 <i>Sport Tilt Helm</i> .....	A-7

A.2	CANtrak Display .....	A-9
A.3	PCM Mounting Dimensions .....	A-11
A.4	Power Steering Pump.....	A-12
	A.4.1 Power Steering Pump Mounting Dimensions .....	A-12
	A.4.2 Floor Mounting the Pumps.....	A-13
<b>Appendix B – CAN Network.....</b>		<b>B-1</b>
B.1	Basic Network.....	B-1
	B.1.1 CAN Bus Connectors.....	B-2
	B.1.2 CAN Bus Connectivity.....	B-3
	B.1.3 Electrical Harness.....	B-3
	B.1.4 Powering the Bus.....	B-4
	B.1.5 CAN Bus Power .....	B-4
<b>Appendix C – Using Datalink.....</b>		<b>C-1</b>
C.1	Dealer Tools.....	C-1
C.2	Connection .....	C-1
C.3	Navigating Datalink.....	C-2
C.4	System Setup .....	C-4
	C.4.1 System Parameters .....	C-4
	C.4.2 Settings Menu Access .....	C-5
	C.4.3 Second Station .....	C-5
	C.4.4 Cycle Power to System.....	C-5
C.5	Purge with Datalink.....	C-6
C.6	Calibrate with Datalink.....	C-7
<b>Appendix D – Using the Color CANtrak Display .....</b>		<b>D-1</b>
D.1	Display Navigation .....	D-1
D.2	Documentation Conventions.....	D-2
D.3	Initial Startup.....	D-3
D.4	Unlocking the Dealer Menu .....	D-3
D.5	Menu Structure .....	D-4
<b>Appendix E – Updating Firmware.....</b>		<b>E-1</b>
E.1	Downloading Software Update Files .....	E-1
E.2	System Software Update .....	E-2
	E.2.1 Using the Color CANtrak display.....	E-2
	E.2.2 Using Datalink.....	E-4
E.3	Checking Component Firmware Revision Levels .....	E-5
	E.3.1 Using CANtrak .....	E-5
	E.3.2 Using Datalink.....	E-5
E.4	Backing Up Component Configuration Files.....	E-7
	E.4.1 Using CANtrak .....	E-7
	E.4.2 Using Datalink.....	E-7
E.5	Updating the CANtrak Software.....	E-8
E.6	Opening a Back-up (ECU) File .....	E-9
E.7	Disabling Automatic Check for Updates.....	E-9
<b>Appendix F - Bolt Torque Specifications.....</b>		<b>F-1</b>

# ABBREVIATIONS

The following abbreviations are used in this manual:

---

ABYC	American Boat & Yacht Council
AUX	Auxiliary
BAT	Battery
CAN	Controller Area Network
CAN Bus	Controller Area Network (data) bus. (A harness of wires that carry digital signals and power between electronic modules)
ENG	Engine
EPS	Electronic Power Steering
FT-LB	Foot Pounds
GND	Ground
HI	High
IN-LB	Inch Pounds
LED	Light Emitting Diode
LO	Low
MPH	Miles Per Hour
NA	Not Applicable or Not Available
N/C	No Connection
Nm	Newton Meters
NMEA	National Marine Electronics Association
NMEA 2000®	A protocol for digital communication on a CAN Bus
PCM	Pump Control Module
RFU	Rudder feedback unit. This is the position sensor on the SmartCylinder.
RPM	Revolutions Per Minute
STBD	Starboard (right when facing forward)
SW	Switch
WOT	Wide Open Throttle

***Note: Some abbreviations not listed here may be found in their respective sections.***



# 1.0 SAFETY INFORMATION

## **⚠ WARNING**

**THE SAFETY INFORMATION PROVIDED HERE IS INTENDED TO INFORM YOU OF THE DANGERS THAT MAY BE PRESENT BEFORE, DURING, AND AFTER INSTALLATION. IT IS CRITICAL THAT YOU READ AND UNDERSTAND THIS INFORMATION.**

Safe operation of the steering system depends upon proper installation and maintenance of the system, and the common sense, safe judgment, knowledge, and expertise of the operator. Every installer and operator of the steering system should know the following requirements before installing or operating the steering system. If you have any questions regarding any of these warnings, contact SeaStar Solutions.

### **Before installation**

1. Read and understand all installation and user's manuals provided with the steering components.
2. Ensure that all components required to complete the installation are on hand (including hoses, fittings, oil, and the proper tools).
3. SeaStar and Optimus components are highly engineered and safety tested to ensure system integrity. **DO NOT** substitute any component. Substitution with non-SeaStar or non-Optimus components may compromise system safety, performance, and reliability.
4. **DO NOT** use a wheel-mounted, coiled cord trim switch. The cord can wrap tight around the steering wheel shaft and inhibit steering.

### **During Installation**

1. Install system components as directed in this manual. Some component parts and kits (such as hoses and fitting kits) are supplied with additional installation instructions—refer also to these instructions.
2. SeaStar and Optimus components are highly engineered and safety tested to ensure system integrity. **DO NOT** substitute any component. Substitution with non-SeaStar or non-Optimus components may compromise system safety, performance, and reliability.
3. If an instruction is unclear, contradictory, or you are otherwise uncertain how to proceed, do not guess. Call SeaStar Solutions technical support.

### **After Installation**

1. Check that there is no interference between the steering cylinder(s), splashwell, outboard engine, or any combination of these parts, by performing the following steps:
  - a) With the engine fully tilted **DOWN**, turn the steering wheel from hard over to hard over and confirm that no interference occurs.
  - b) Repeat step 1a with engines tilted **UP**.
  - c) Perform step 1a with each engine in alternating **DOWN/UP** positions and confirm that independent **TRIM/TILT** can be done without any interference.
2. Check that the steering cylinder can be fully stroked in both directions, as well as full tilt and trim, without stretching, chafing rubbing, or kinking of the hydraulic hoses and electrical harnesses.
3. Check that only SeaStar Pro steering hose (1500psi rating) has been used to plumb the system.

---

**Prior to every use**

Perform a system inspection as outlined below. Refer to Section 8.2 for further details.

1. Check steering fluid level in all steering pumps.
2. Verify immediate steering response when turning steering wheel(s).
3. Inspect all steering hoses, fittings, mechanical cables, and electrical harnesses for wear, kinks, or leaks.
4. Check for binding, loose, worn or leaking steering or shift/throttle control components.
5. Verify proper shift and throttle response for all control handles.
6. Verify that no alarms or warnings are shown on the CANtrak display.

---

**⚠ WARNING**

**DO NOT OPERATE BOAT IF ANY COMPONENT IS NOT IN PROPER WORKING CONDITION.**

---

**During use**

1. WEAR A COAST GUARD-APPROVED PERSONAL FLOTATION DEVICE (PFD).
2. ATTACH ENGINE SHUT-OFF CORD (LANYARD) TO YOUR PFD.
3. Never allow anyone who is not familiar with the operation of the steering system to operate the boat at any time.
4. If boat is equipped with multiple helms, ensure that only one is used at a time.
5. Know and adhere to all applicable federal, state, and municipal laws and regulations that govern boating in your area.

---

**⚠ WARNING**

**DO NOT OPERATE BOAT IF ANY COMPONENT IS NOT IN PROPER WORKING CONDITION.**

---

**After use**

Rinse off the SmartCylinders thoroughly, using only fresh, clean water. DO NOT rinse the PCM, pumps, actuators, or any other component of the Optimus system.

DO NOT use acetone, or cleaners containing ammonia, acids, or any other corrosive ingredients on any Optimus components.

---

**⚠ WARNING**

**Failure to comply with any warning, notice or caution may lead to loss of steering control resulting in a collision and/or ejection from the boat leading to property damage, personal injury and/or death.**

# 1.1 Safety Labels

**⚠ WARNING**

The labels below should call attention to the possible hazards associated with the equipment shown later in this manual.

**Power steering pump Labels**



**HYDRAULIC STEERING PUMP**

<b>PART No. EP1500</b>	SERIAL NO:
6.9 MPa (1000psi) MAX. 12 Volt	12-100001

**⚠ WARNING**  
**DO NOT OPEN VALVE WITH ENGINE(S) RUNNING**

**⚠ WARNING**

Prior to use check fluid level in pump reservoirs. Install and maintain in accordance with SeaStar Solutions installation manuals. Use SeaStar Electronic Power Steering Fluid ONLY. NEVER use brake fluid. Any non-approved fluid may cause irreparable damage resulting in loss of steering control and may void warranty. Failure to comply with the above warnings may result in loss of steering control, leading to possible ejection from vessel causing property damage, personal injury and/or death.

**STEERING SERVICE VALVE**

Refer to User's Manual for use of valve.

**OPERATION:**

- TURN OFF ENGINES
- FULLY TURN KNOB COUNTER-CLOCKWISE TO OPEN
- MANUALLY MOVE ENGINE(S) TO REPOSITION
- FULLY TURN KNOB CLOCKWISE TO CLOSE

MEMBER  
**ABYC** SAE J-1171

SEASTAR SOLUTIONS  
 RICHMOND, BC, CANADA



882130



Figure 1-1. Power steering pump labels.

**Pump Control Module  
(PCM) Labels**

<b>⚠ CAUTION</b>	
<b>BATTERY POST</b>	<b>Nm 3.5 MAX. 2.5 MIN.</b>
<b>TORQUE VALUES</b>	<b>IN-LB 30 MAX. 22 MIN.</b>
	<b>MAXIMUM</b> 6 AWG < 3.0m (9.8ft)
	<b>BATTERY LEAD</b> 4 AWG < 4.5m (14.7ft)
	<b>LENGTH</b> 2 AWG < 7.5m (24.6ft)

CAN 1	CAN 1	CAN 3	CAN 2
<b>EM1100 PUMP CONTROL MODULE</b>		<b>OPTIMUS</b>	
<b>⚠ WARNING</b>		SERIAL NUMBER:	
RFU 1	<p>REFER TO INSTRUCTIONS FOR SPECIFIC APPLICATION. INSTALL AND MAINTAIN IN ACCORDANCE WITH SEASTAR SOLUTIONS INSTRUCTIONS. FAILURE TO COMPLY WITH ABOVE MAY RESULT IN LOSS OF STEERING CONTROL, LEADING TO POSSIBLE EJECTION FROM VESSEL CAUSING PROPERTY DAMAGE, PERSONAL INJURY AND/OR DEATH.</p>	 BY <i>Seastar</i>	RFU 2
		 <b>ABYC</b> <small>Safety Standards for Yacht Boating</small>	SEASTAR SOLUTIONS ISO 25197 Ignition Protected SAE J1171 Patent Pending
		<b>12V</b>	

TORQUE VALUES	
Nm	3.5 MAX 2.5 MIN
IN-LB	30 MAX 22 MIN

MAX. BATTERY LEAD LENGTH	
6AWG < 3.0m (9.8ft)	
4AWG < 4.5m (14.7ft)	
2AWG < 7.5m (24.6ft)	

<b>⚠ WARNING</b>	
<b>Improper installation may cause loss of boat control. Follow Rigging Manual carefully. • Secure all connections.</b>	
<ul style="list-style-type: none"> <li>• Cap all unused connectors.</li> <li>• Secure cables to tabs with cable ties.</li> </ul>	
<small>682300</small>	

Figure 1-2. PCM labels.

**Ignition Connection  
Label**

<b>⚠ WARNING</b> Avoid loss of control: Ensure proper connection per instructions.	<b>⚠ WARNING</b> Avoid loss of control: Ensure proper connection per instructions.
<small>682300</small>	

Figure 1-3. Ignition warning decal, PID# 682300.

## SmartCylinder Labels

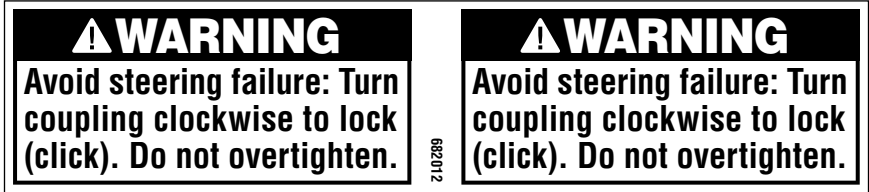

SEASTAR SOLUTIONS RICHMOND, BC, CANADA	<b>PART # EC5310, 6.9 MPa (1000psi) MAX SMART STEERING CYLINDER</b>	ISO10592 Patents Pending CE ABYC
<b>PRIOR TO EVERY USE:</b> 1. Check fluid level in pump reservoirs (consult User's Manual). 2. Verify immediate steering response when turning steering wheel(s). 3. Inspect all steering hoses, fittings & cables for wear, kinking and/or leaks. 4. Check for binding, loose, worn or leaking steering components. DO NOT operate boat if any component is not in proper working condition.	<b>INSTALLATION, USE AND MAINTENANCE:</b> 1. Ensure steering cylinder is compatible with outboard engine & U.S.C.G. ratings. 2. Interference with any object <b>MUST</b> be corrected prior to use. 3. Maintain steering system at a minimum of twice per year. 4. Refer to Installation and User's Manuals for important safety information. 5. Ensure all electrical connections are properly secured and free from corrosion. 6. Keep magnets away from steering cylinders.	
<b>WARNING</b> Failure to adhere to these warnings may result in loss of steering control, leading to possible ejection from vessel causing property damage, personal injury and/or death. <a href="http://www.seastarsolutions.com">www.seastarsolutions.com</a> 682009		

Figure 1-4. SmartCylinder labels.

## Steering Service Valve Labels

To be installed close to the service valve.

Figure 1-5. Steering service valve labels.

*This page left intentionally blank.*

# 2.0 SYSTEM OVERVIEW

## 2.1 System Description

Optimus EPS is a steer-by-wire system that replaces a traditional hydraulic helm with electronic components that communicate over a serial data network. This state-of-the-art system incorporates many advanced features to make it safe and reliable. These features include redundant sensors, fault-tolerant communications, extensive self-monitoring, and fault communications to notify and advise the operator in case of a system fault.

The Optimus EPS system consists of several major components, listed below. Refer to figures 2-1 and 2-2 to see these components in a schematic system diagram.

### CAN Networks

CAN (controller area network) is a serial network protocol that is widely used in marine and automotive control systems. Each device (node) on the network can send and receive data using specially formatted messages. The ability to reliably communicate data between devices is what enables the steer-by-wire functionality of Optimus EPS. Optimus EPS uses up to three independent CAN networks, designated CAN1, CAN2, and CAN3.

- CAN1 is a low-speed, fault-tolerant network with two pairs of signal wires in each cable. It is used for safety-critical communications.
- CAN2 is a high-speed network that is well-suited for non-critical tasks such as passing data to and from the CANtrak display.
- CAN3 is a public network using the NMEA 2000 protocol. The Optimus system broadcasts public messages onto this network, and can also monitor the network for engine RPM. Use of this network is optional.

More information about CAN may be found in Appendix B.

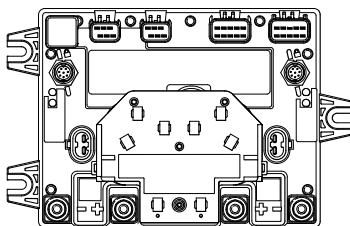
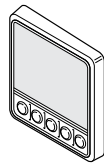
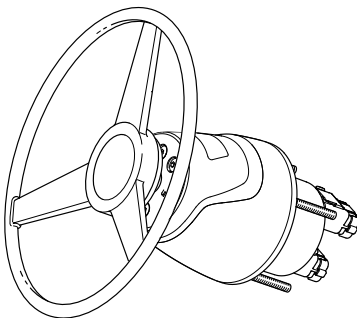

### Electronic helm

The helm converts steering wheel movement into digital messages that are sent over CAN1 to the pump control module (PCM). A system of friction plates in the helm allow the steering effort to be adjusted according to a setpoint received from the PCM. (A steering wheel is not included with the Optimus EPS system.)

### CANtrak display

The CANtrak display is a small color LCD that displays system status and fault information to the operator. It is also used to make changes to user-adjustable steering settings. Authorized installers have access to additional menus with system setup and calibration tools.

### Pump control module (PCM)

The PCM receives wheel movement messages from the helm(s) and operates the hydraulic steering pumps to steer the vessel as required. The PCM uses position feedback from the SmartCylinders for precise steering control and fault detection. The PCM can also respond to inputs from a certified autopilot system.

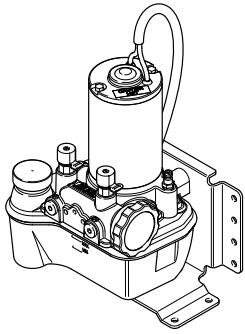

### **Power steering pumps**

The power steering pumps supply pressurized fluid to the SmartCylinders in order to steer the boat. The PCM controls a 12V DC motor that drives a small gear pump. The pump assembly has an integral fluid reservoir and pressure relief valves.

The steering pumps have an integral service valve that can be opened to bypass the pumps and allow the engines to be manually repositioned. They are used for service or in the case of an emergency.

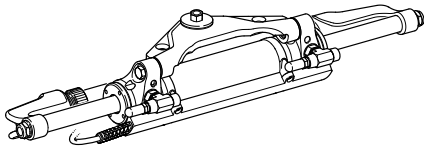

### **SmartCylinders**

The SmartCylinder is a hydraulic steering cylinder fitted with a magnet and a position sensor. Each SmartCylinder can steer up to two outboard engines.

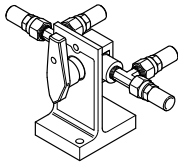

### **Remote-mounted steering service valves (optional)**

When the service valves on the power steering pumps are not easily accessible these optional remote-mounted valves can be installed in a convenient location.



## 2.2 Optimus EPS System Diagrams

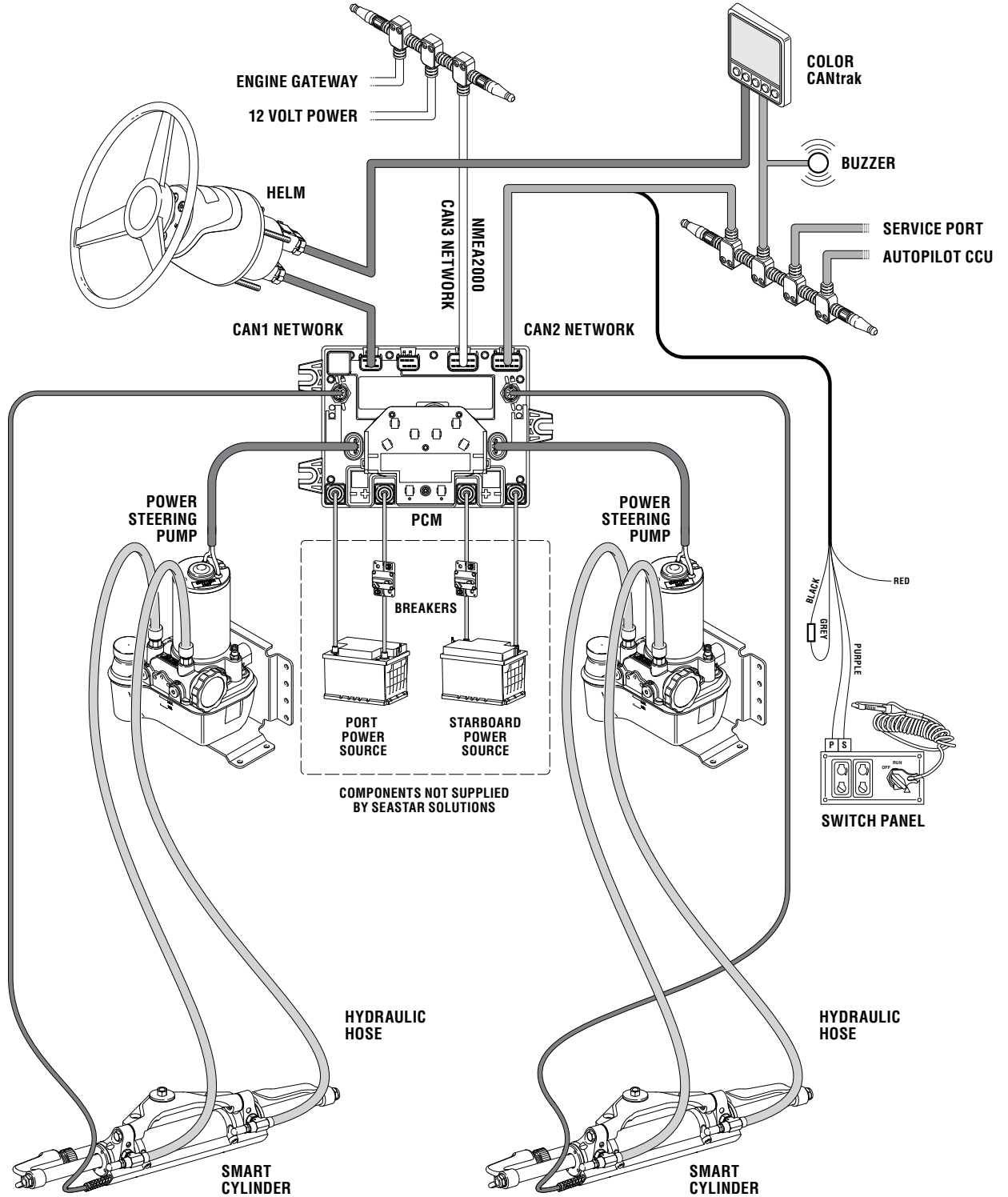

Figure 2-1. Optimus EPS system diagram, single station, twin engine.

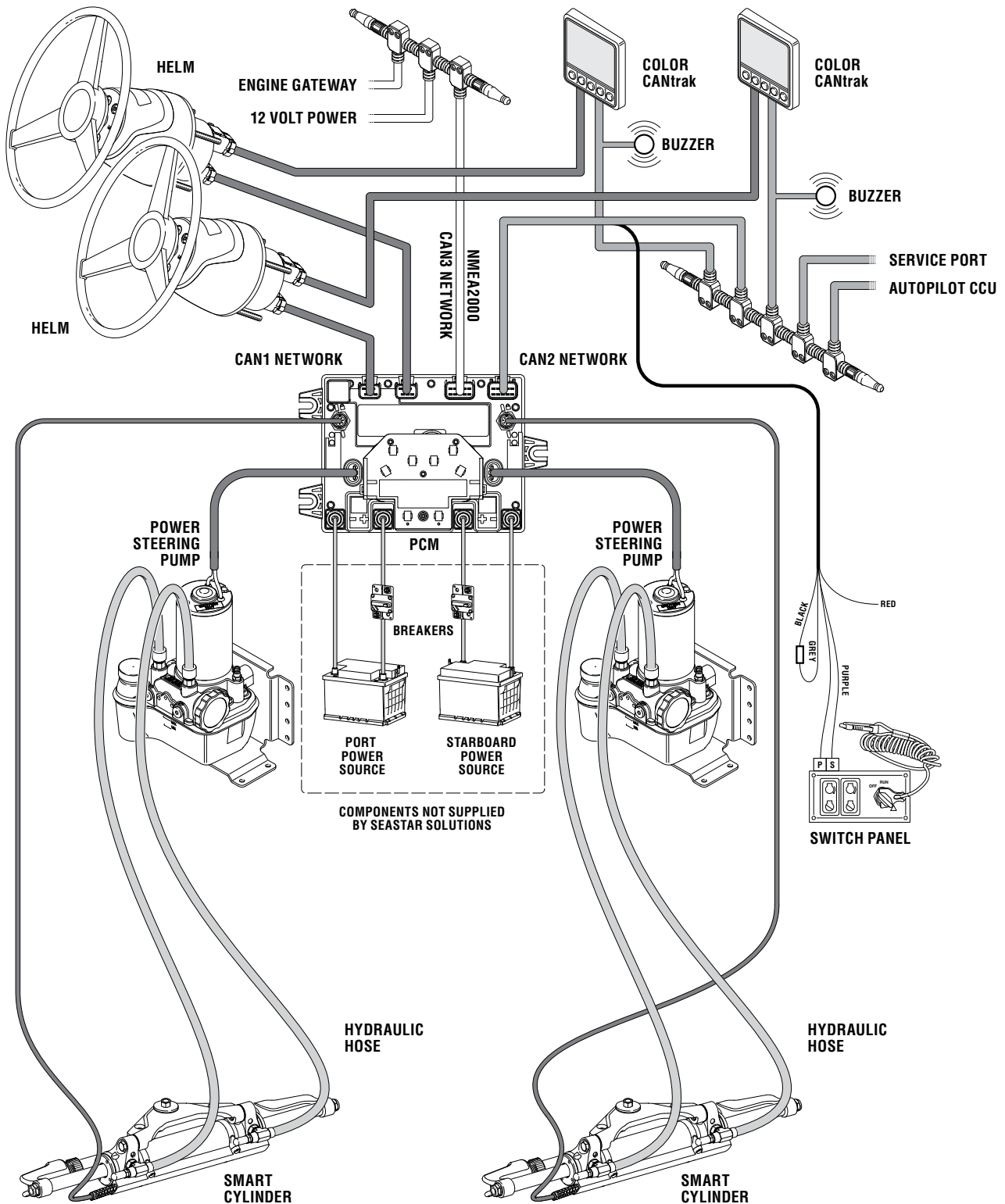

Figure 2-2. Optimus EPS system diagram, dual station, twin engine.

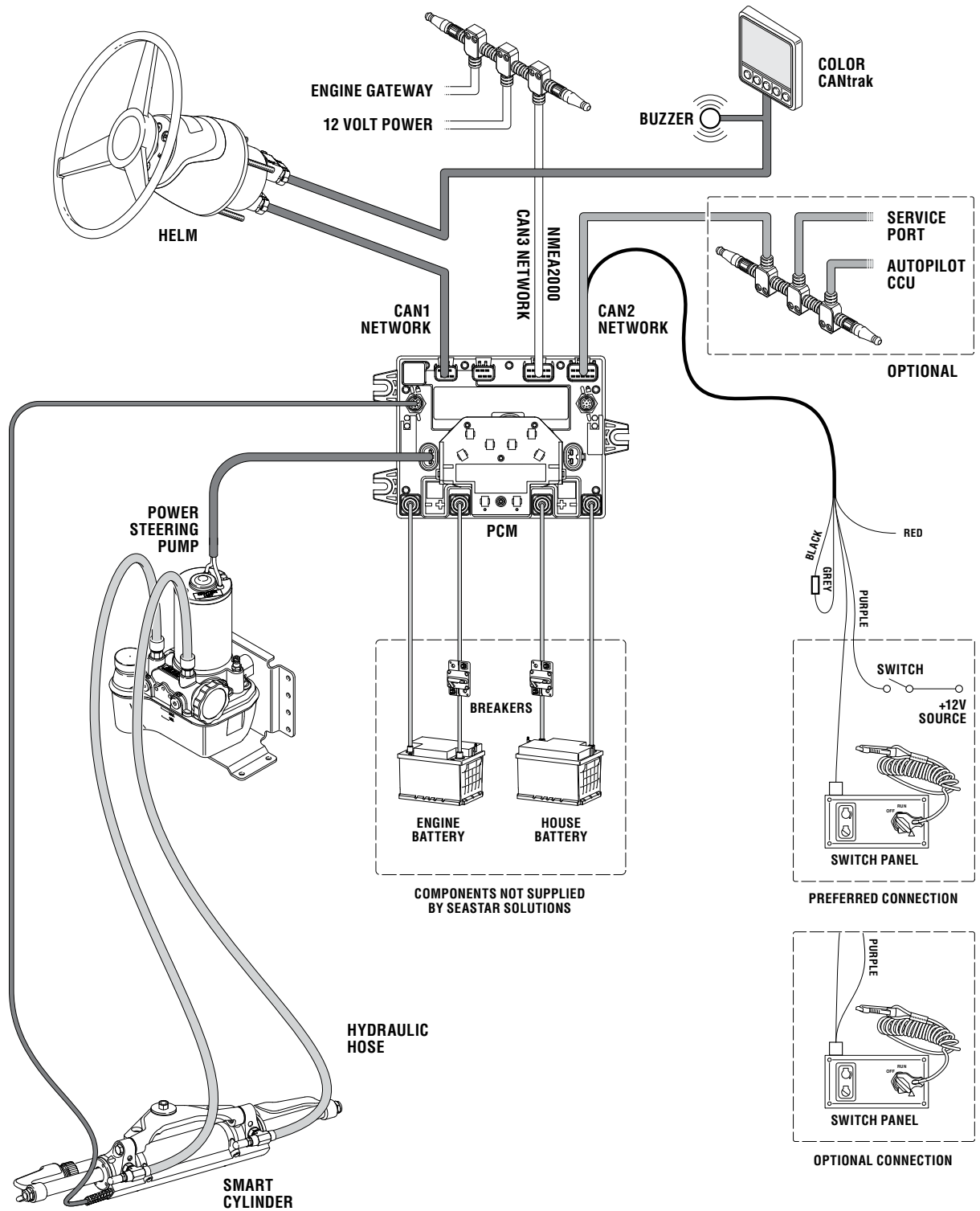

Figure 2-3. Optimus EPS system diagram, single station, single engine.

*This page left intentionally blank.*

# 3.0 INSTALLATION OVERVIEW

## 3.1 Important Information/Technical Support Contact

---

To ensure proper installation and maintenance of this steering system, please note the following:

- Installation must be performed by a SeaStar Solutions authorized installer.
- Read and understand all installation instructions provided with the system and its components before starting the installation.
- Read and understand all the safety information noted in this manual and all other installation instructions..

If you need technical assistance, or wish to report an error in our documentation, please contact SeaStar Solutions technical support:

### **Technical Support**

Web: [www.seastarsolutions.com](http://www.seastarsolutions.com)

E-mail: [seastar@@seastarsolutions.com](mailto:seastar@@seastarsolutions.com)

Phone: 604.248.3858

Fax: 604.279.2202

## 3.2 Installation Summary

---

There are several stages in the installation of the Optimus EPS system, listed below. By reviewing this summary you will better understand each step in the context of the entire installation.

### **Planning (Section 4)**

- Acquire a general understanding of the system and its various components.
- Check that the equipment supplied is available and correct.
- Establish suitable locations for each component.
- Plan the cabling and the hose connections.
- Consider the power connections to the battery and the breaker location. All wiring should be done to ABYC guidelines.
- Consider where the ignition and tach sources will come from.
- Verify that you have a dealer setup kit for purge & calibration.
- Make a diagram of the system as it pertains to the particular boat installation.

### **Component Installation (Section 5)**

- Mount the helm.
- Mount the CANtrak.
- Mount the pump control module (PCM) and the power steering pumps.
- Install the SmartCylinders.
- Install the remote service valves (if necessary).
- Install the hoses.

### **Networks and Wiring (Section 6)**

- Review network diagrams
- Install network tees.
- Connect network harnesses.
- Install circuit breakers and run the power wires.
- Connect ignition wires.
- Connect engine RPM source.
- Connect autopilot if required.

### **Purging, Calibration and Setup (Section 7)**

- Purge the hydraulic system.
- Calibrate the SmartCylinders
- System setup with CANtrak.

### **Commissioning (Section 8)**

- Installation checks
- Sea trial
- Steering adjustments
- Warranty checklist

# 4.0 PLANNING

The parts shown below are supplied in the installation kit. The following sections detail the parts and their suggested placement. Refer to Section 5 for detailed installation instructions.

## 4.1 Planning

### **⚠ CAUTION**

**It is highly recommended that a complete review of Section 4 is done in order to assemble the appropriate materials and ensure that proper installation techniques are understood.**

Review each of the major components shown in Section 4.2 and consider where to place them, keeping in mind the various mounting restrictions.

Check that the harness connections can be made without violating any of the cabling restrictions. Determine if the available harness are sufficient or if it is necessary to order any additional harness or cabling components.

Ensure that you understand the CAN network requirements and have the required components available. Review Appendix B for important information about planning the CAN network.

Plan the location of the breakers and the connections to the batteries, keeping in mind the ABYC requirements. Confirm the required breakers are at hand. Make sure that sufficient wire of the correct gauge is available with the correct termination hardware and tie straps.

Review the required hoses and fittings and check that all are available.

Document the information on the system diagram.

## 4.2 Required Parts

Check that following parts are available for the installation:

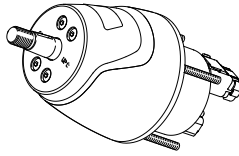

**Helm**

One per helm station

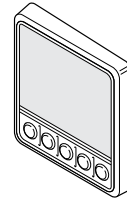

**CANtrak Display**

One per helm station

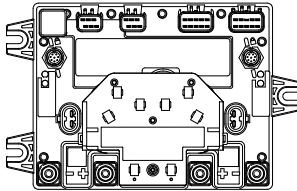

**Pump Control Module (PCM)**

One PCM is required

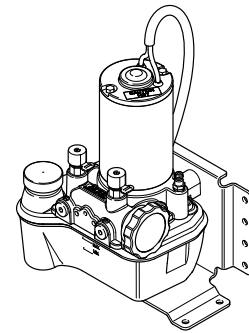

**Power steering pump**

One per engine (single/twin)  
or engine pair (triple/quad)

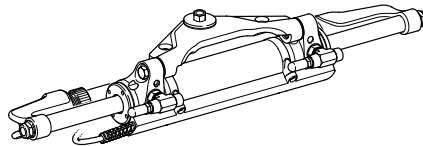

**SmartCylinder**

One per engine (single/twin)  
or engine pair (triple/quad)

*Figure 4-1.*

Other parts required (not shown):

- SeaStar Pro Steering Hoses
- SeaStar Electronic Power Steering Fluid (Green/blue color)
- Dealer Installation Kit and Purge Hose
- Electrical harnesses and wire(s) (some wire[s] not supplied by SeaStar Solutions)
- Breakers – two 60 Amp (not supplied by SeaStar Solutions)
- Steering wheel (not supplied by SeaStar Solutions)



## 4.3 Plan Your Component Placement

Review the detailed information for each of the following components and determine where they will be located on the boat. Pay particular attention to the harness length information, as this may impact the choice of component locations. During this process, confirm that the correct harness lengths are available.

### 4.3.1 Electronic Helm(s)

The helm is an electronic unit and send signals to the Pump Control Module (PCM) via an electrical harness supplied with the system. There is no steering fluid in the helm.

There are four helm styles available for the Optimus EPS system. One is required for each helm station. On multiple helm station boats, different style helms may be used at different stations.

#### **⚠ CAUTION**

**The helm may effect a ship's or the autopilot's compass. For less than one degree of effect keep the EPS helm and the compass a minimum of 24 inches (61 cm) apart.**



EPS Front Mount Helm  
Part No. EH1510

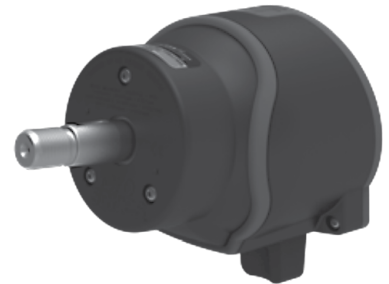

EPS Sport Plus Tilt Helm  
Part No. EH1530



EPS Classic Tilt Helm  
Part No. EH1550



EPS Rear Mount Helm  
Part No. EH1570

Figure 4-2.

For mounting templates, please see Appendix A.

The harness length from the PCM to the farthest helm may not exceed 36 total feet. Harness are available in 6-foot incremental lengths to cover various installations and CANNOT be extended.

**⚠ CAUTION**

**Total harness length CANNOT exceed 36 feet.**

<b>CAN1 HARNESS – HELM TO PCM</b>		
One harness is required for single helm station, two are required for multiple helm stations.		
DESCRIPTION	LENGTH	PART No.
Harness, EPS, H4, 6 PIN FCI	6 FOOT	CM20406
Harness, EPS, H4, 6 PIN FCI	12 FOOT	CM20412
Harness, EPS, H4, 6 PIN FCI	18 FOOT	CM20418
Harness, EPS, H4, 6 PIN FCI	24 FOOT	CM20424
Harness, EPS, H4, 6 PIN FCI	30 FOOT	CM20430
Harness, EPS, H4, 6 PIN FCI	36 FOOT	CM20436

Table 4-1.

**Single Helm Harness Length**



**Multiple Helm Harness Lengths (Preferred Arrangement)**

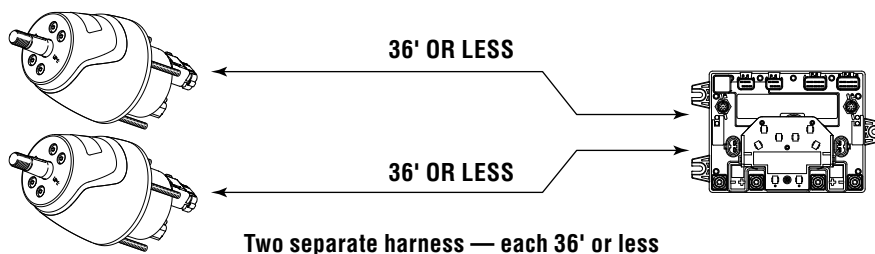

**Multiple Helm Harness Lengths (Optional Arrangement)**

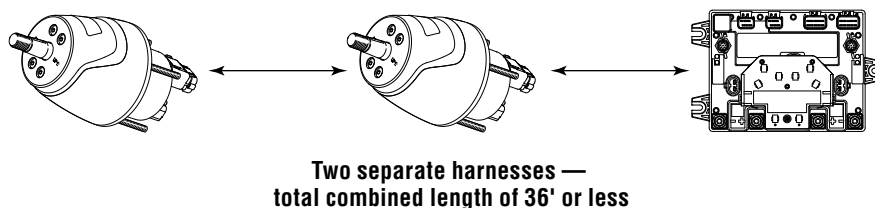

Figure 4-3.

### 4.3.2 CANtrak Display

#### NOTICE

A CANtrak display is required at the main helm station, but is optional at secondary control station(s).

All CANtrak Displays are identical and can be used at any station. The display must be easily visible from the helm station. The display may be located in any position, however it is strongly suggested that, if it is exposed to the weather, it should be on a sloped surface so water does not lay on the screen.

For mounting templates, please see Appendix A.



Part No. ED1700

## DO

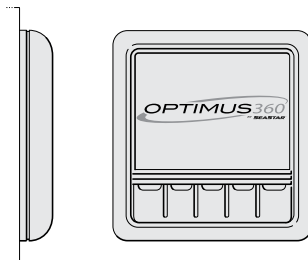

Mount vertical to hull or wall

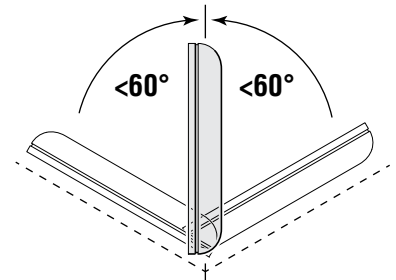

Mount at an angle less than  $60^\circ$

## DO NOT

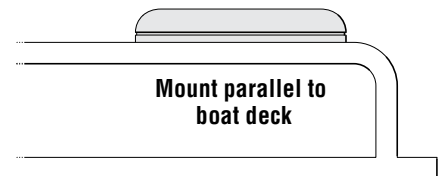

Figure 4-4.

The following cabling is required to connect the CANtrak on multi-engine installations. These connections are not used on single-engine applications.

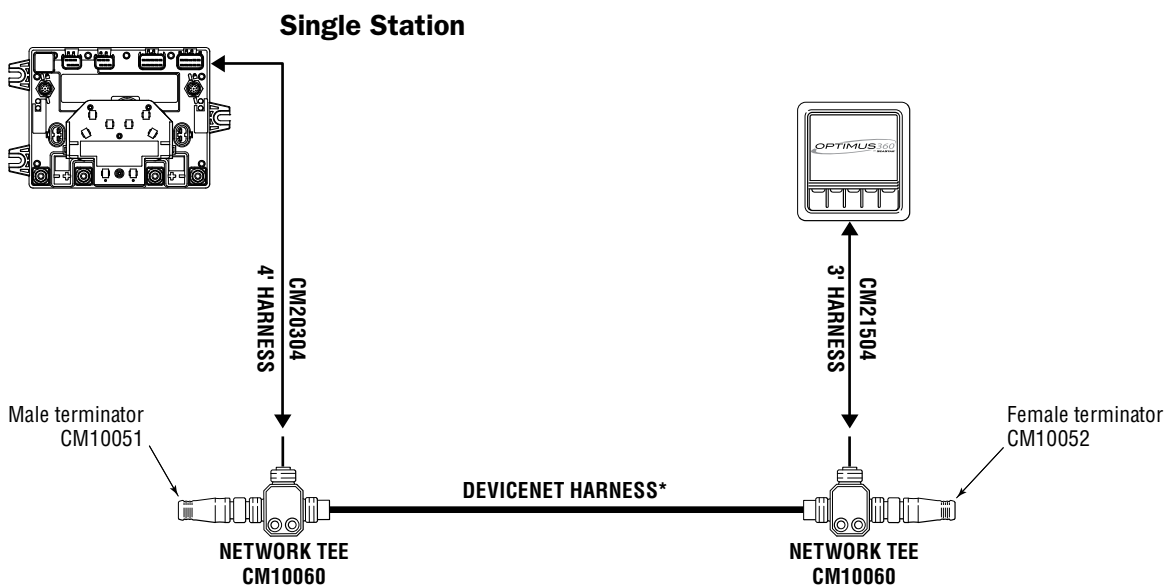

Figure 4-5.

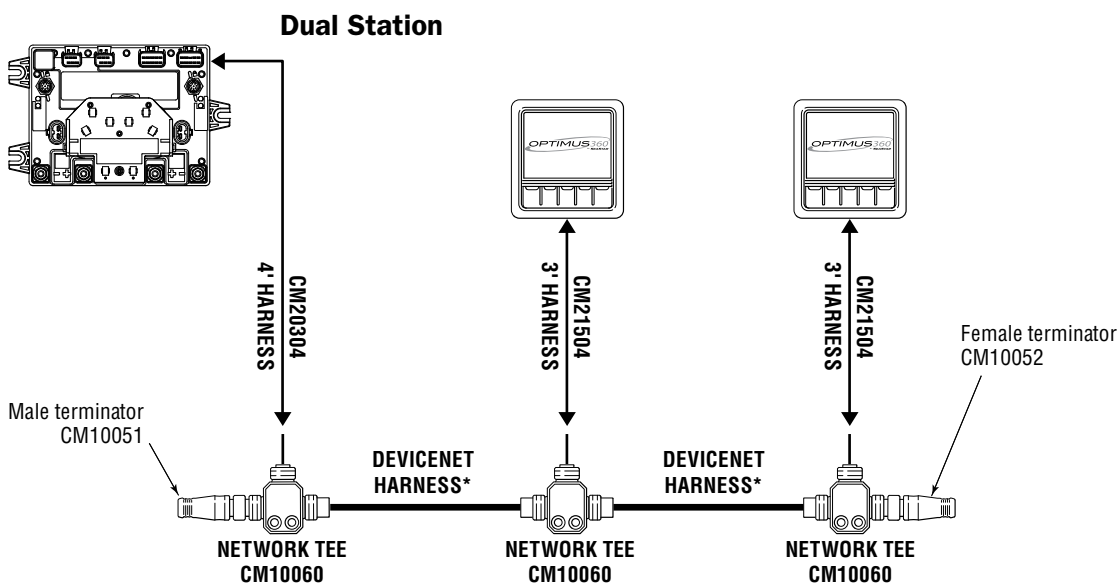

Figure 4-6.

\* Note: see next page for harness information.

**⚠ CAUTION**

**Choose the correct Micro-C DeviceNet harness length. DO NOT chain multiple DeviceNet harness together.**

Available DeviceNet extension harness shown in table below.

<b>MICRO-C DEVICENET HARNESS</b>		
<b>DESCRIPTION</b>	<b>LENGTH</b>	<b>PART No.</b>
Micro-C Extension, Male/Female	6 Foot	CM10006
Micro-C Extension, Male/Female	9 Foot	CM10009
Micro-C Extension, Male/Female	12 Foot	CM10012
Micro-C Extension, Male/Female	16 Foot	CM10016
Micro-C Extension, Male/Female	20 Foot	CM10020
Micro-C Extension, Male/Female	30 Foot	CM10030

*Table 4-2.*

**⚠ CAUTION**

**DO NOT cut or splice DeviceNet harnesses.**

**⚠ CAUTION**

**Do not connect anything other than SeaStar Optimus components, or SeaStar approved autopilots, to the CAN2 network.**

### 4.3.3 Pump Control Module (PCM)

The PCM should be mounted in a cool, dry area and **MUST** be mounted in such a way that the three foot harness supplied with the power steering pumps reach the PCM. The Pump harness **MUST NOT** be extended. Do a dry fit, with the leads properly run through the strain relief plate to verify the harness will reach before permanently mounting the pumps.

Each PCM has two independent power feeds, each of which must be connected to a power source by means of a 60 amp breaker. The breaker should be mounted within seven (7) inches of the power source per ABYC wiring standards or a second breaker may be required to protect the wire. The PCM **MUST** be mounted as shown. For mounting templates, please see Appendix A.

#### ⚠ CAUTION

**DO NOT use Automatic Power Selectors (APS) or selector diodes of any kind on the PCM power or ignition wires. This functionality is already built into the PCM.**

#### ⚠ WARNING

**ALL ELECTRICAL CONNECTIONS AND HARNESS MUST COMPLY WITH ABYC WIRING STANDARDS, BE RATED FOR 105°C (221°F), AND COMPLIANT WITH SAEJ1128.**

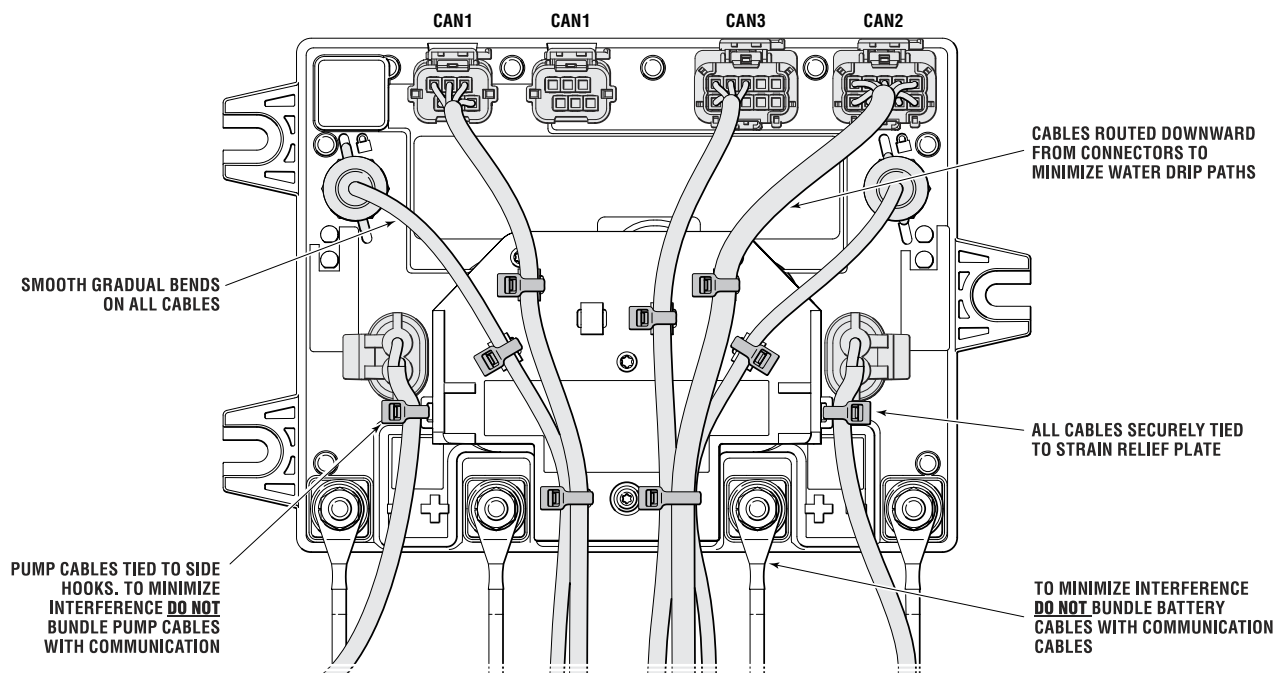
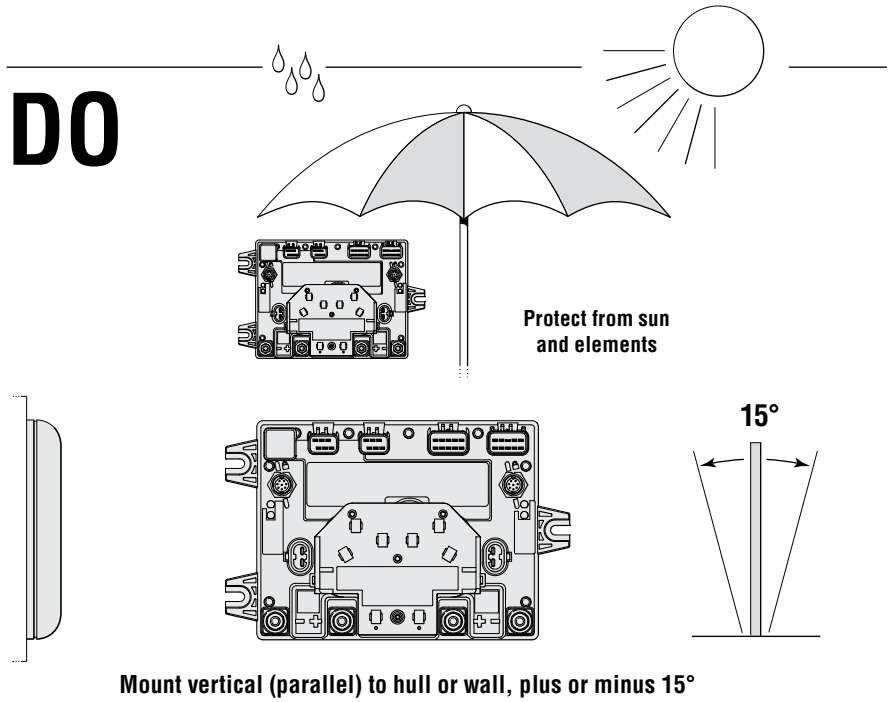

Figure 4-7 Part No. EM1110.

**⚠ WARNING**

**Make sure that all unused ports have sealing plugs.**

Considerations for mounting the PCM.



**DO NOT**

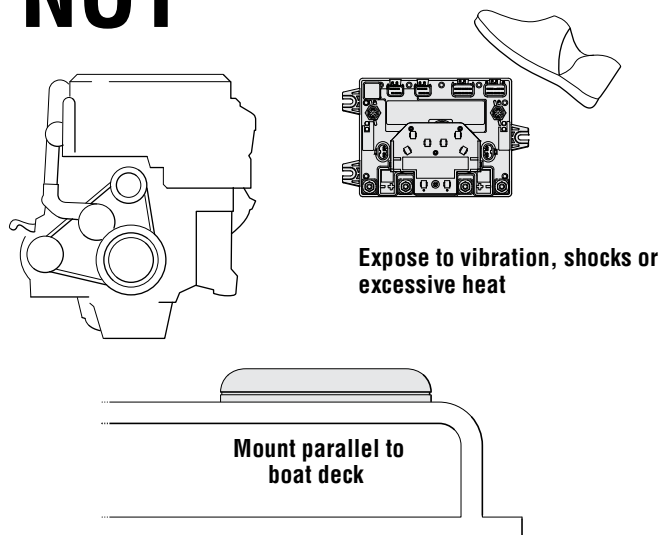

Figure 4-8.

## 4.3.4 Power Steering Pump

The power steering pumps provide the fluid flow to move the SmartCylinders. The pumps can be mounted to the floor, a vertical wall or to the transom. The pumps should be in a dry location and must be able to connect to the PCM with the three foot harness supplied with the pump. Do a dry fit, with the leads properly run through the PCM strain relief plate to verify the harness will reach before permanently mounting the pumps.

### ⚠ CAUTION

**This harness must NOT be extended.**

The power steering pump makes a moderate amount of noise when operational. Try to select a location that will minimize the noise in the passenger area.

Typical locations for the power steering pumps and the PCM are behind the helm area on center console boats or in the rear compartment of cruisers. Don't overlook the possibility of mounting these items in the base of the seating area. The mounting location of these items will have the most impact on the overall ease of installation and long term system maintenance so take time deciding on the best location. For mounting dimensions see Appendix A.

Some considerations:

- It is easier to run small electrical harness than hydraulic hoses and heavy power wires.
- The operator will need to check the steering fluid level in the power steering pumps on a regular basis.
- The steering service valves *must* be accessible to the operator in case of emergency. If you can't locate the pumps in a way that makes the valves accessible, use the remote service valve kit, HA5480, as shown in section 4.3.6.
- Service and maintenance operations will be performed for the life of the boat. The installation is performed once.

### NOTICE

Hose fittings can be relocated to plugged ports if required. (See figure 4-9, item 1 and 2.) Torque hose fittings to 18 ft-lb (24 Nm) and plugs to 50 in-lb (6 Nm).

You can also install 90° fittings (Kit # HF6004) for additional hose routing flexibility.

### NOTICE

Due to material variability, fitting installation torque differs between the power steering pump and the steering cylinder. Be sure to use the correct installation torque to avoid irreparable damage to the pump housing or cylinder body when installing an ORB fitting.

# DO

Part. No.  
EP1500

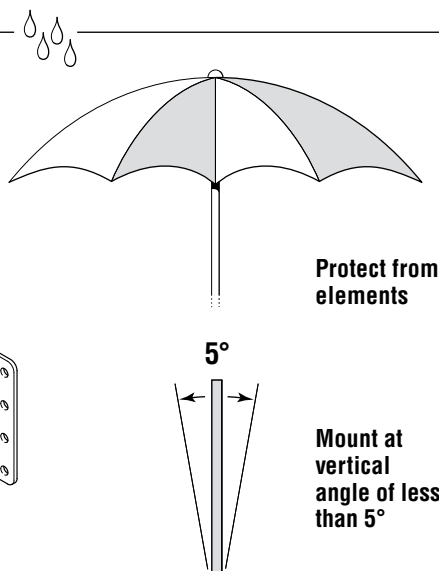
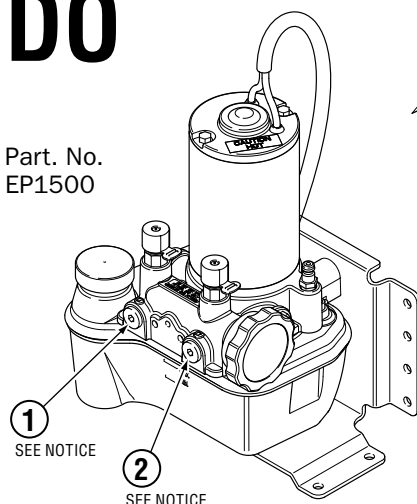

Figure 4-9.



### 4.3.5 SmartCylinders

The SmartCylinders move the engines and supply a feedback signal that tells the PCM where the engines are positioned. Each SmartCylinder connects to a power steering pump by means of two hoses, and connects to the PCM by means of an electrical harness. The SmartCylinder hoses and the electrical harness must be run in a fashion to assure they have room for complete travel. It is very important that the hydraulic hoses and harness from each SmartCylinder are installed in such a way that gives the cylinder full travel at all tilt positions without kinking or snagging on an obstruction.

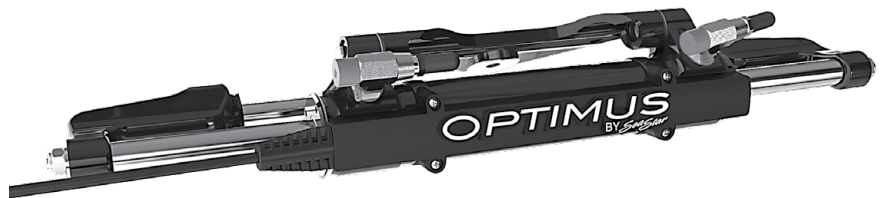

Figure 4-10.

The SmartCylinder comes with an 18 foot electrical harness which connects to the PCM. There are three lengths of extension harness available, if required. Up to two extension harnesses may be added to each SmartCylinder. Take care to locate the harness connections in dry areas (or a junction box) and provide strain relief on either side of each connection.

DESCRIPTION	LENGTH	PART NO.
SmartCylinder Harness Ext. EPS, H9	6 foot	CM20906
SmartCylinder Harness Ext. EPS, H9	12 foot	CM20912
SmartCylinder Harness Ext. EPS, H9	18 foot	CM20918

Table 4-3.

#### **⚠ CAUTION**

**Only two extension harnesses are permitted per SmartCylinder.**

#### **⚠ WARNING**

**THE SMARTCYLINDER ELECTRICAL HARNESS MUST BE ATTACHED TO THE HYDRAULIC HOSE WITH CABLE TIES. SEE SECTION 5.7.2.**

### 4.3.6 Steering Service Valves

---

The steering service valves are integrated with the power steering pumps. When open they allow the engines to be manually repositioned, and are used for maintenance or in case of emergency. The pumps must be installed so that the valves are accessible and visible to the operator. The supplied decal (figure 1-5) must be applied in a visible location near the service valve.

If you can't install the pumps in such a way that the valves are accessible, use the remote-mounted service valve kit HA5480 (one per steering cylinder). These service valves can be mounted in a convenient location.

Turn the knob fully counterclockwise (about 3 turns) to open the service valve, and clockwise to close. Turn just until you feel the valve contact the stop – do not use tools or overtighten.

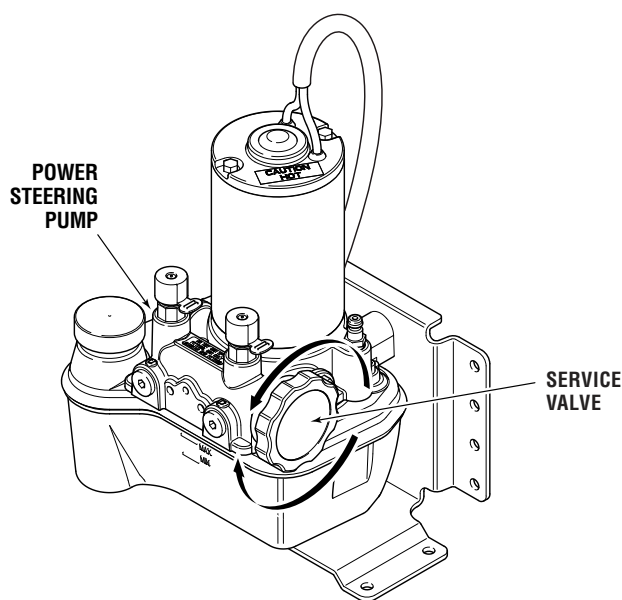

Figure 4-11. Service valve location.

### 4.3.7 Circuit Breakers

---

These must be supplied by the installer and typical mounting choices are near the batteries, near the pumps or in a circuit breaker panel. A 60 amp circuit breaker is required for each of the two PCM power feeds.

Use only circuit breakers designed for marine use, and with corrosion-resistant, stainless steel connection hardware.

Refer to ABYC wiring standards for all wiring best practices.

## 4.4 Plan Your Connections

At this point of the planning process the location of all major components should be established. Now it is time to review and plan your hydraulic and electrical connections.

### 4.4.1 Hydraulic Hoses

#### **⚠ WARNING**

**THE OPTIMUS EPS SYSTEM REQUIRES THE USE OF KEVLAR REINFORCED HOSES ONLY. DO NOT USE EXTRUDED NYLON TUBING OR STANDARD SEASTAR (1000PSI) HOSE.**

SeaStar Pro steering hoses are available in kits containing two equal length hoses. Determine the length of the required hoses from each pump to its associated SmartCylinder, and check that you have the proper hoses available.

If you are using remote-mounted service valves (HA5480) you will need two sets of hoses for each cylinder: one pair from the pump to the service valve and a second pair from the service valve to the cylinder.

Consider the following when planning your hose routing and determining the required lengths:

- The cylinder body moves as the motor or outdrive is articulated. Ensure there is sufficient hose length to allow full, uninterrupted steering motion, including trim and tilt.
- Minimum bend radius on the hose is 3.5". Never route the hoses in such a way that they can kink.
- Hoses should be secured along their routing path whenever possible, and should not be allowed to hang free in any area where they may become a safety hazard. SeaStar Solutions recommends the use of a rigging tube, PVC piping, or conduit for the safe installation and protection of the steering hoses.
- DO NOT install hoses in such a way that they may become exposed to hot engine components, such as manifolds or exhaust components.
- DO NOT install hoses where they may be exposed to corrosive acids, such as those that may be found at battery connection points, or where they may be exposed to battery fumes.

Two types of hose are offered:

1. Bulkhead hoses are used when the hose must pass through a bulkhead. They are supplied with your choice of polished stainless steel or black anodized aluminum bulkhead plates, and come with pigtail fittings to secure the hoses. See figure 4-12.
2. Standard hose kits have no bulkhead plate and are used for straight point-to-point runs.

Table 4-4 shows the available hose kits. Each kit comes with two hoses.

KIT PART No.	DESCRIPTION	BULKHEAD PLATES
H057XX	SeaStar Pro hose kit	None
H082XX	SeaStar Pro bulkhead hose kit	2 x black anodized
H087XX	SeaStar Pro bulkhead hose kit, SS	2 x polished stainless steel
H089XX	SeaStar Pro bulkhead hose kit, SS, double	1 x polished stainless steel

*XX denotes hose length in feet, with a leading zero for lengths below 10 feet. Available lengths:*

- 2 to 5 feet in 1 foot increments (e.g. for a 3 foot hose kit, order H05703)
- 6 to 30 feet in 2 foot increments

Table 4-4.

**⚠ WARNING**

**DO NOT INSTALL BULKHEAD HOSES BELOW THE WATERLINE.**

**Bulkhead Hoses**

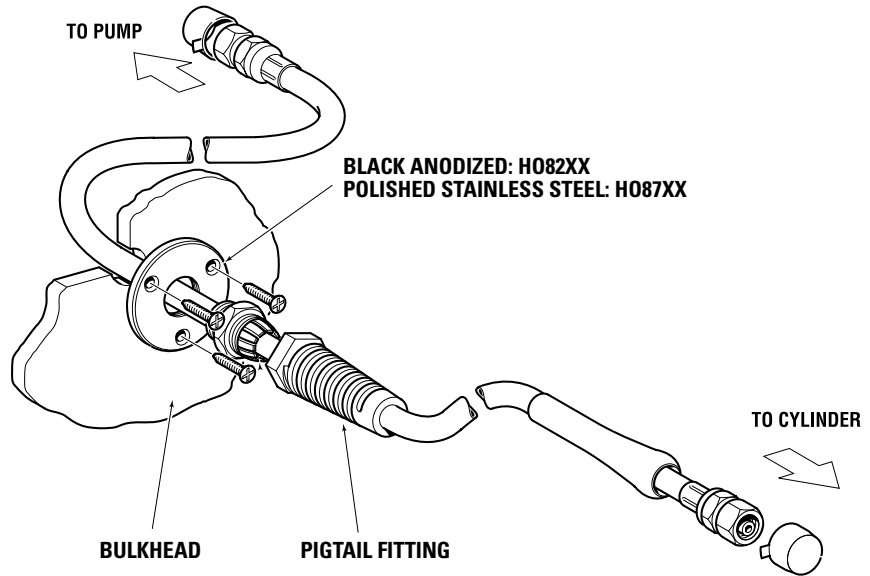

Figure 4-12. Single bulkhead plate.

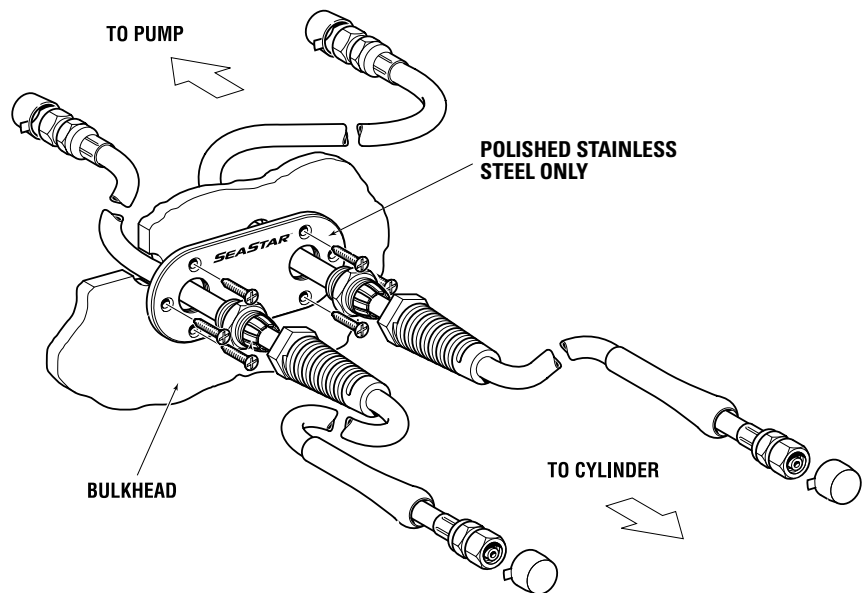

Figure 4-13. Dual bulkhead plate.

## 4.4.2 Power Connections

### ⚠ CAUTION

**The Optimus EPS system is not designed for 24 volt operation. Damage may occur.**

#### **Single Engine Applications:**

Connect power to both sides of the PCM as shown in this section. This provides redundant power to the PCM.

If the boat has only a single battery you will need to get a second.

Connect the engine battery to the port side terminals of the PCM and the house battery to the starboard side. The system will only draw power from the house battery if the engine battery is low.

#### **Triple and Quad Engine Applications:**

There are special considerations when making power connections on a triple or quad system. See page 4-17 for information.

All system wiring and power connections must be made to ABYC standards. See *ABYC E-11 AC and DC Electrical Systems on Boats*.

The Optimus EPS system requires a 12V DC power source, and can draw a peak current of approximately 40 Amps when the steering is in heavy use. It is important that the power supply wires are correctly sized for the load.

#### **Typical Source Connections**

- Direct to the batteries.
- To battery switches. *Never* switch the negative wire.
- To a bus bar or power distribution panel. Ensure that the wire size from the bus to the batteries is sufficient to handle the peak current of *all* accessories connected to the bus. Many boats have a positive and/or negative bus behind the helm or in the center console. These are typically supplied to handle light accessory loads and usually do not have sufficient wire size to supply the EPS system. In general, buses that supply power to vessel electronics such as radar and GPS are usually not acceptable power sources for the EPS system.

ABYC standards require that all wires carrying positive voltage must have a circuit protection device within 7" of the power source. The EPS system requires a 60A circuit breaker that is designed for marine use.

In some installations the 60A circuit breaker may need to be located more than 7" from the power source. In this case an additional protection device (breaker or fuse) must be located within 7" of the battery to protect the intervening wire. The device must be rated based on wire size, and is usually of a slightly higher current rating than the 60A breaker. Be sure to factor in the entire wire length from PCM to source when selecting wire size. Refer to ABYC E-11 for more details.

See figure 4-14 for source connection examples.

#### **Wire Type and Sizing**

Use wire with red insulation for the positive connections, and wire with black or yellow insulation for the negative connections.

The positive and negative power wires are frequently routed along different paths. For each wire, determine the length required to connect from the PCM to the power source or ground, then select the correct wire size from table 4-5.

WIRE LENGTH FROM PCM TO POWER SOURCE		AWG (mm <sup>2</sup> )
< 3.0 meters	< 9.8 feet	6 (13.5)
< 4.5 meters	< 14.7 feet	4 (21)
< 7.5 meters	< 24.6 feet	2 (34)

Table 4-5.

## Examples

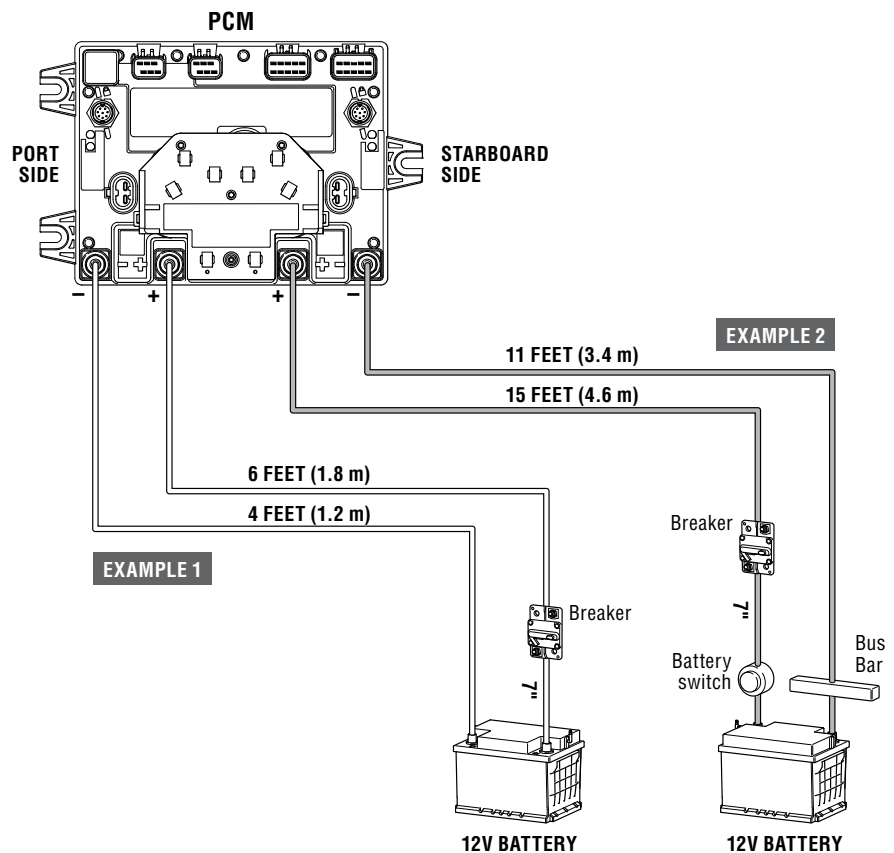

Figure 4-14. Examples.

### Example 1

The negative cable is 4' (1.2 m) and according to the table you can use 6 AWG (min 13.5 mm<sup>2</sup>) wire. The positive cable is 6' (1.8 m) and requires a circuit protection device within 7" (18 cm) of the power source. The total length is still below 9.8' (3 m) so again 6 AWG (13.5 mm<sup>2</sup>) wire can be used.

### Example 2

The negative wire is going from the PCM to a good ground bus. The negative wire is 11' (3.4 m) long and the table indicates that 4 AWG (21 mm<sup>2</sup>) wire is required. The positive wire is 15' (4.6 m) long and goes from the breaker to the PCM. The 7" (18 cm) run from the battery switch to the breaker must be added, resulting in a total length of 15' 7" (4.8 m). Checking the table results in a 2 AWG (34 mm<sup>2</sup>) wire for this connection.

### Triple and Quad Engine Applications

To prevent the Optimus EPS/360 system from draining batteries while trolling on a single motor, it is necessary to connect the batteries in such a way that the PCM is always connected to a battery being charged. Figure 4-15 illustrates a possible triple engine connection using battery switches with a combine function and an automatic charging relay (ACR). In this example, if the user is trolling on the center engine the ACR will detect that the starboard battery is being discharged and connect it to the center battery. This ensures that the steering system will not deplete the battery.

#### NOTICE

For clarity only positive wire connections are shown.

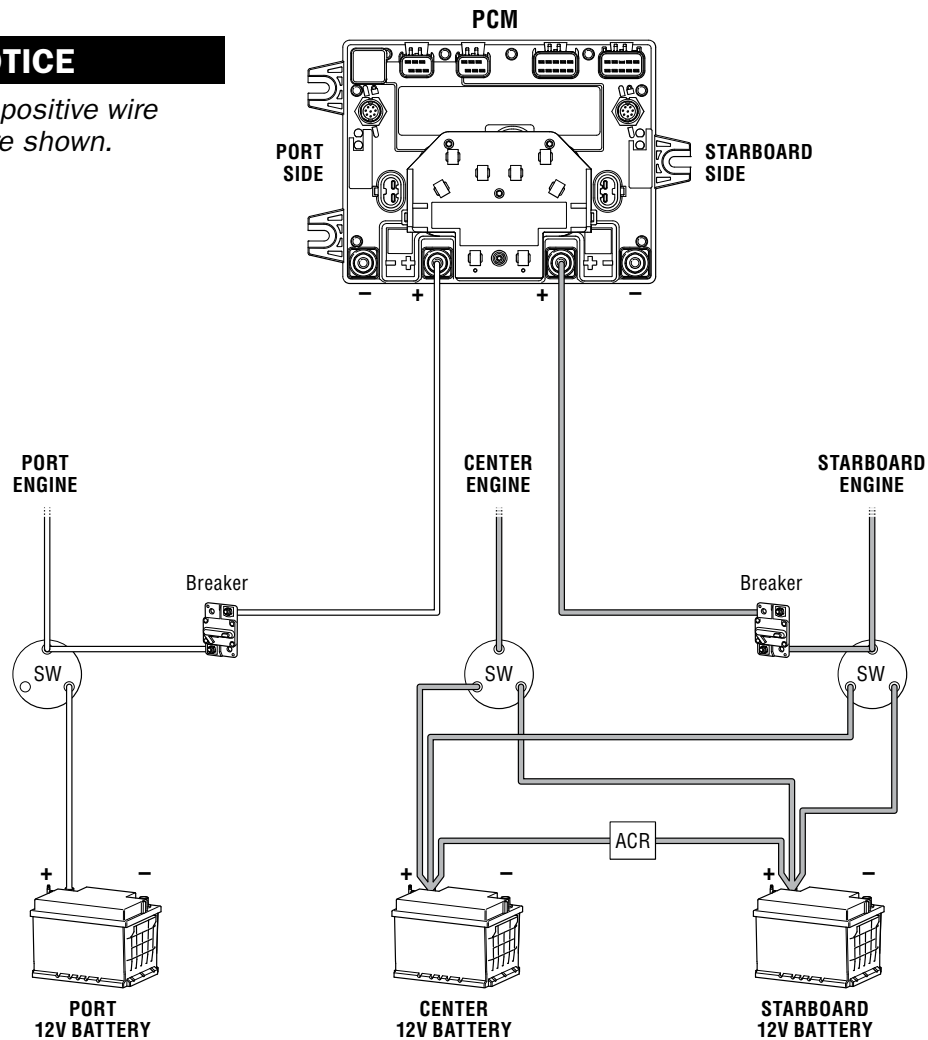

Figure 4-15. Sample triple engine connection with ACR.

Figure 4-16 shows a possible connection for a quad engine vessel, but without ACRs. In single engine trolling this connection does not guarantee that the PCM is connected to a charging battery, so the battery switch for the running engine must be set to 'Both' (or '1+2' or 'All' on some switches). If the engines are always trolled in pairs (inboard pair or outboard pair) the position of the battery switches is not important because one charging battery will always be connected to the PCM when connected as shown.

To make your system as error-proof as possible, SeaStar recommends the use of ACRs as shown in figure 4-15.

**NOTICE**

*For clarity only positive wire connections are shown.*

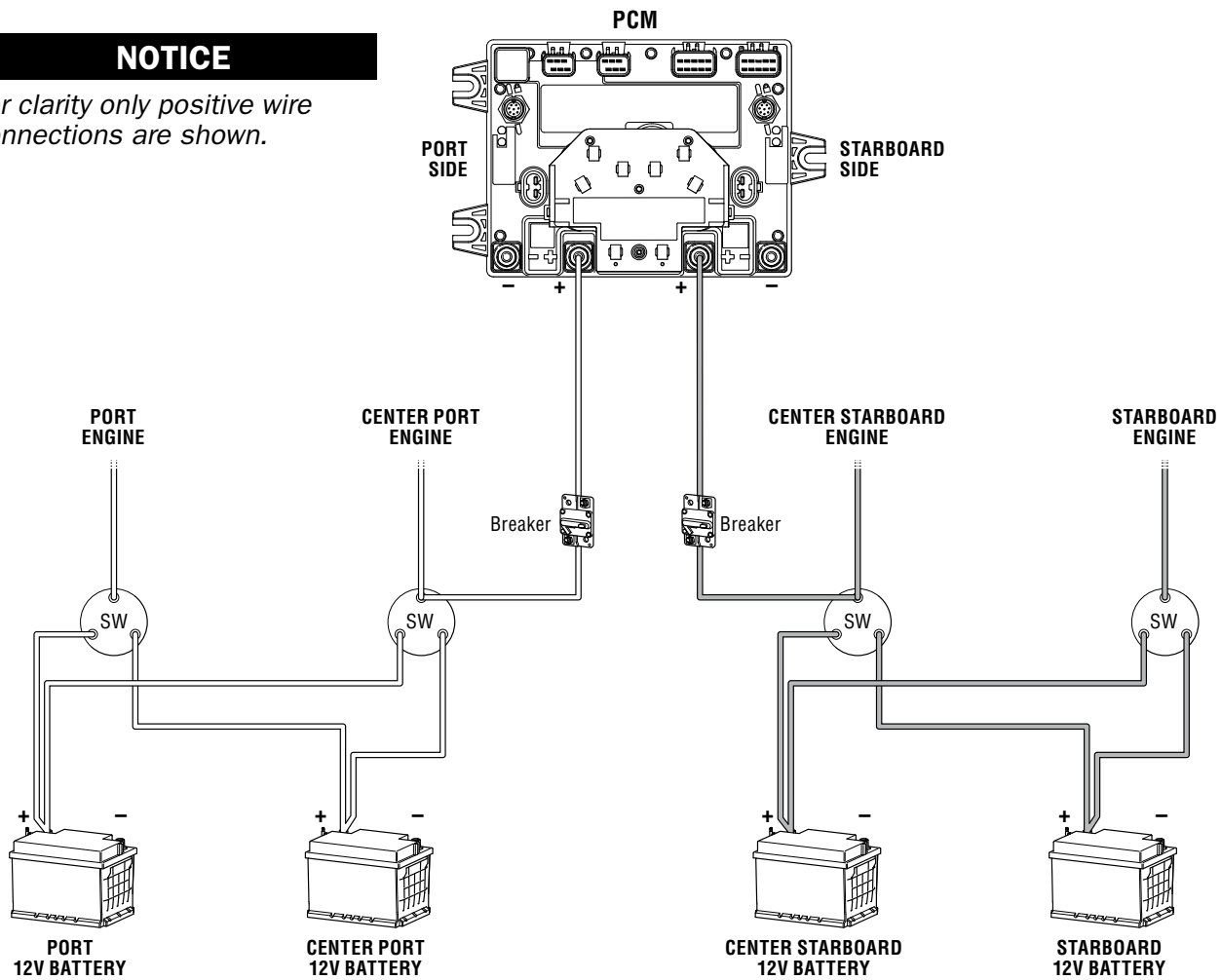

Figure 4-16. Sample quad engine connection without ACR.



### 4.4.3 Ignition & Tachometer Connections

The PCM's ignition sensing leads must be connected in such a way that an ignition-on signal is received when any of the engine ignition switches are on. On twin-engine applications you simply need to connect the two ignition-sensing leads on the CM20304 harness to the port and starboard switched ignition wires. These are usually violet or yellow wires, found on the back of the ignition switches.

Triple- and quad-engine applications may already be wired to deliver such an ignition signal. If not you may require the use of one or two Dual Ignition Kits (HA1201). The Dual Ignition Kit combines two ignition sources into a single signal. You would need one kit for a triple, and two for a quad.

The EPS system requires an engine speed input (RPM).

- The input can be an analog tachometer input and connected to the PCM through the CM20304 harness.
- The signal can be from an RPM source on the NMEA 2000® CAN Bus using the optional CM20503 NMEA 2000® interface cable. This will require PGN 127488 be on the CAN Bus.
- See Sections 6.4 through 6.5 for details.

### 4.4.4 Optional Autopilot Connection

The Optimus EPS system can take steering commands from compatible autopilot units through a simple CAN2 network connection. No additional hydraulic pumps or connections are required. Refer to [www.seastarsolutions.com](http://www.seastarsolutions.com) for compatible autopilot systems.

An additional network tee on the CAN2 network will be required (CM10060). You may also need a DeviceNet extension harness to extend either the CAN2 backbone or the autopilot harness. Extension harnesses are listed in section 4.3.2.

Refer to the autopilot installation instructions for additional information.

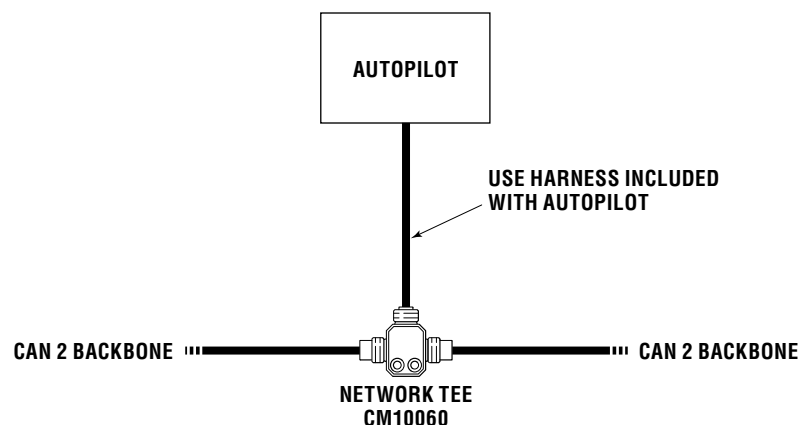

Figure 4-17. Autopilot connection to CAN 2 network.

## 4.5 Diagram

Use this page to make a complete diagram of the installation. The diagram should be similar to the one in Section 2.2, with the locations and correct harness and hose lengths indicated.

---

Helm area:

PCM/Pump area:

SmartCylinder area:

# 5.0 COMPONENT INSTALLATION

## NOTICE

*Refer to Section 4 – Planning, before proceeding with any part of the installation. This will speed the installation and avoid problems that could occur due to lack of up-front planning.*

## 5.1 Mounting the Helm(s)

Follow these guides when mounting Optimus EPS Helms:

- Mounting for all models is similar to all SeaStar Solutions hydraulic helms.
- Although some mounting hardware has been updated, installation methods are the same.

There are four Optimus EPS helms available for installation: Front Mount, Rear Mount, Classic Tilt, and Sport Plus Tilt. On multiple helm installations, any type helm may be used at either station.

See the following pages for installation diagrams.

## NOTICE

*On multiple helm installations write down the serial number of the helms and note which station they are installed at. This will simplify the configuration process (section 7.1)*

## ⚠ WARNING

**ALL HELMS MUST HAVE A GROUND CONNECTION TO THE GROUND, NEGATIVE BUS BAR, OR THE NEGATIVE SIDE OF THE BATTERY TO PREVENT DAMAGE FROM STATIC ELECTRICITY. A GROUND STRAP AND HARDWARE IS PROVIDED WITH EACH HELM.**

**FAILURE TO DO SO MAY RESULT IN LOSS OF STEERING CONTROL, POSSIBLY RESULTING IN PROPERTY DAMAGE, INJURY OR DEATH.**

## 5.1.1 EPS Front Mount Helm (EH1510)

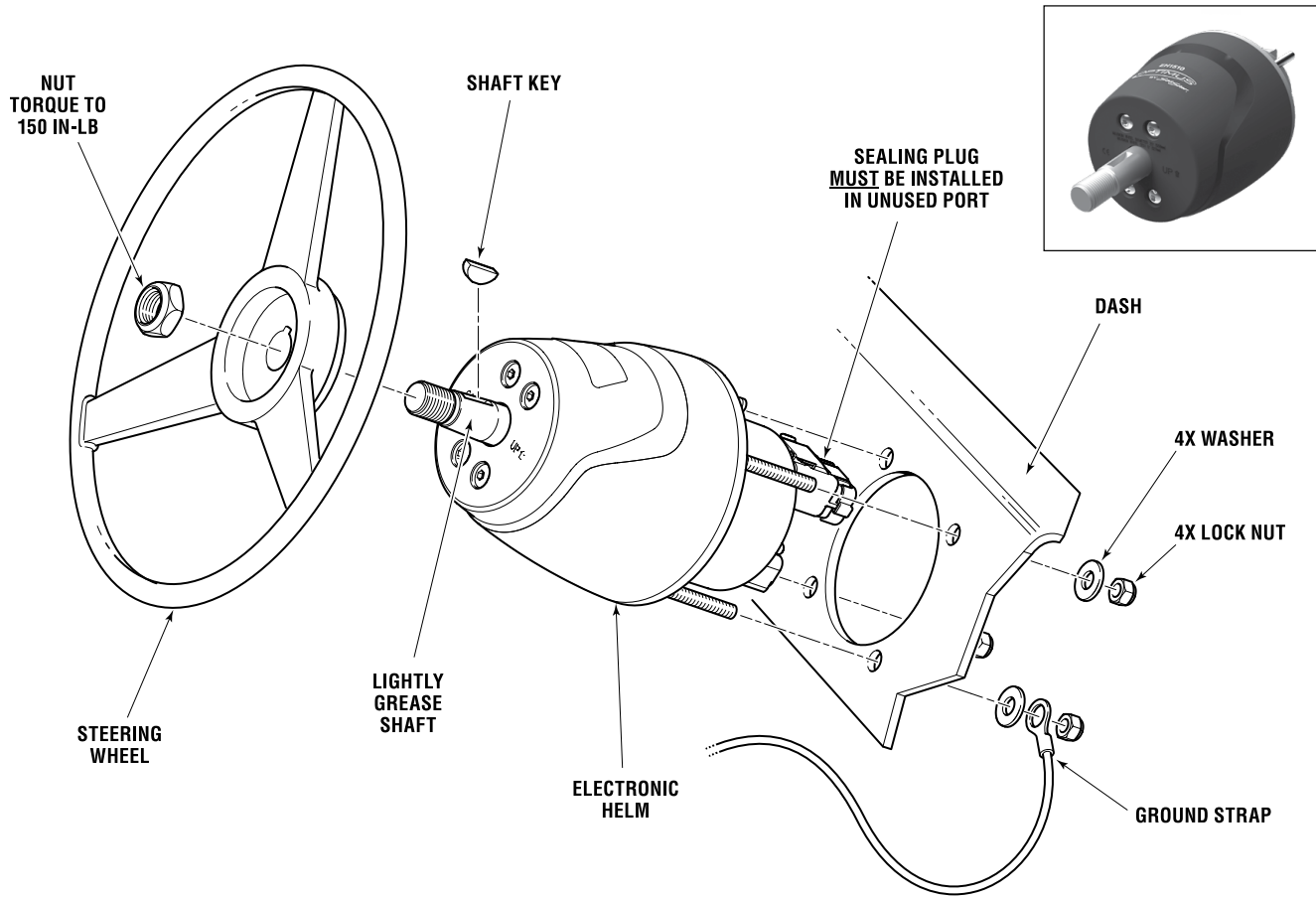

Figure 5-1.

See Appendix A for Mounting Template

**Install the ground strap** - install one end of the ground strap between the nut and washer on the helm's mounting stud. Connect the other end to ground or negative bus bar or to the battery negative terminal.

### ⚠ WARNING

**USE ONLY THE SELF-LOCKING FASTENERS PROVIDED! SUBSTITUTING NON-SELF-LOCKING FASTENERS CAN RESULT IN LOOSENING OR SEPARATION OF EQUIPMENT, CAUSING LOSS OF STEERING CONTROL, PROPERTY DAMAGE, PERSONAL INJURY AND OR DEATH. DO NOT EXCEED 110 IN-LB, (12NM) TORQUE ON HELM NUTS AND BOLTS.**

## 5.1.2 EPS Sport Plus Tilt Helm (EH1530)

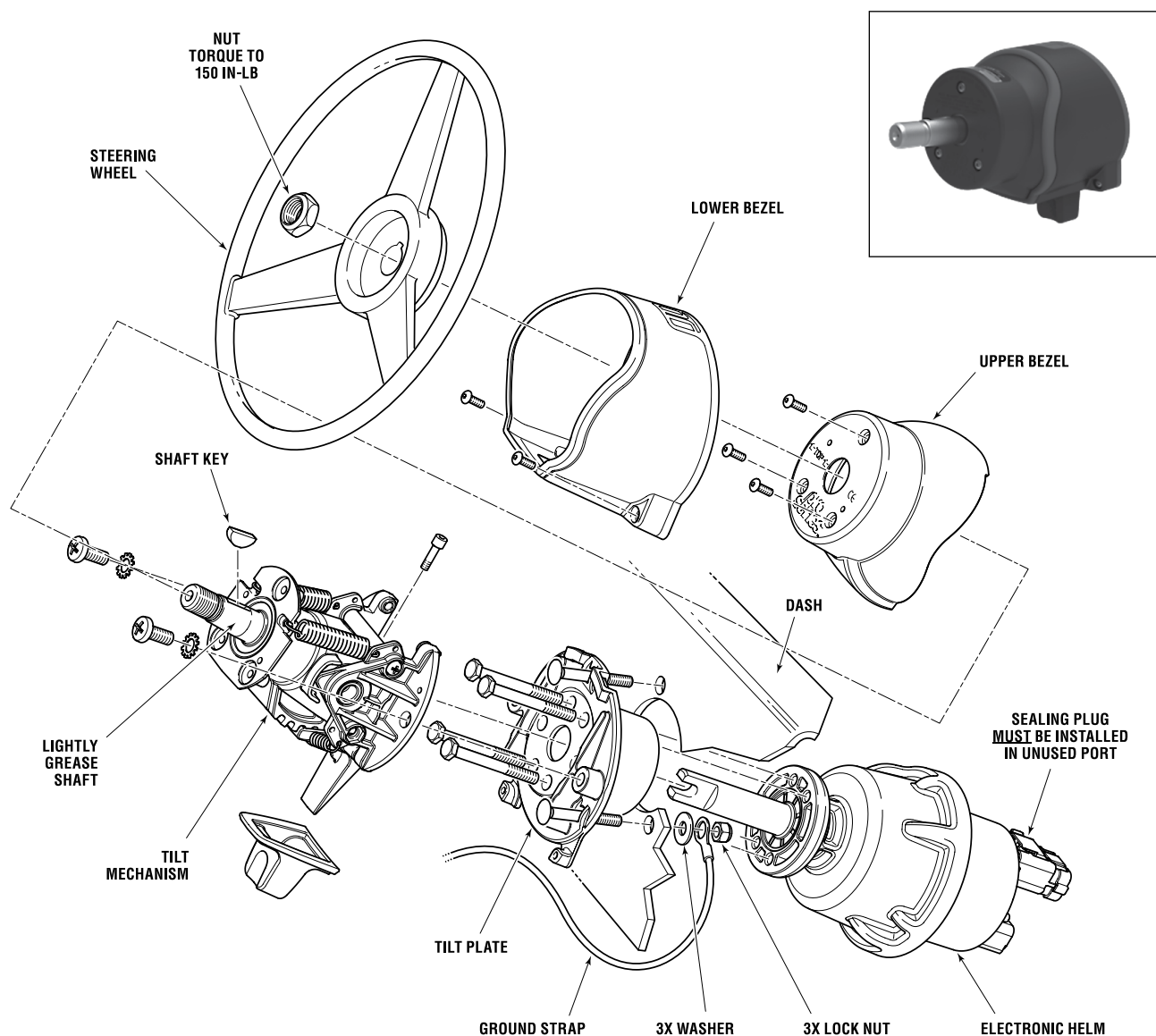

Figure 5-2.

### See Appendix A for Mounting Template

**Install the ground strap** - install one end of the ground strap between the nut and washer of one of the carriage bolts holding the adapter plate to the dash. Connect the other end to ground or negative bus bar or to the battery negative terminal.

### **⚠ WARNING**

**USE ONLY THE SELF-LOCKING FASTENERS PROVIDED! SUBSTITUTING NON-SELF-LOCKING FASTENERS CAN RESULT IN LOOSENING OR SEPARATION OF EQUIPMENT, CAUSING LOSS OF STEERING CONTROL, PROPERTY DAMAGE, PERSONAL INJURY AND OR DEATH. DO NOT EXCEED 110 IN-LB, (12NM) TORQUE ON HELM NUTS AND BOLTS.**

### 5.1.3 EPS Classic Tilt Helm (EH1550)

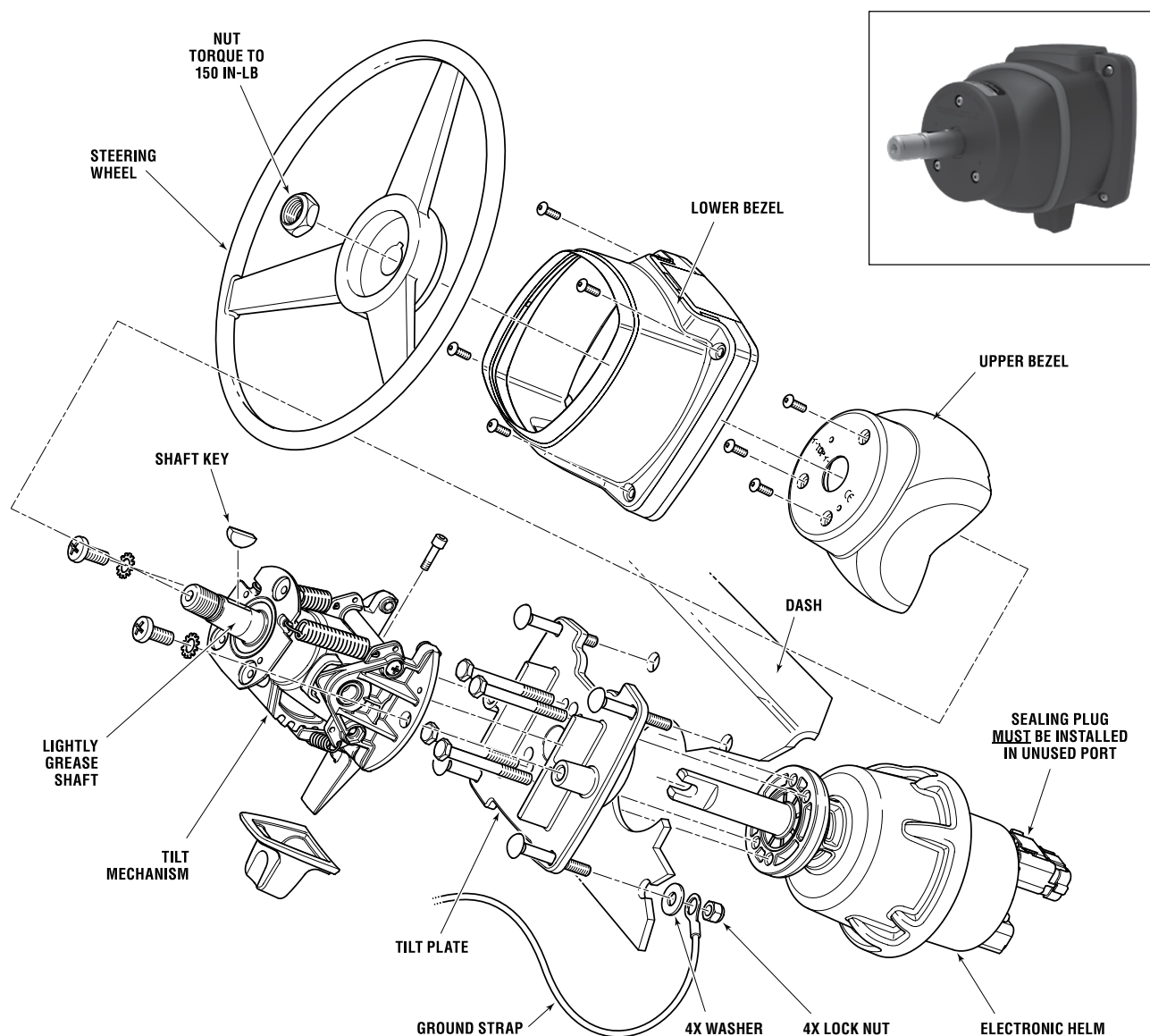

Figure 5-3.

#### See Appendix A for Mounting Template

**Install the ground strap** - install one end of the ground strap between the nut and washer of one of the carriage bolts holding the adapter plate to the dash. Connect the other end to ground or negative bus bar or to the battery negative terminal.

#### **⚠ WARNING**

**USE ONLY THE SELF-LOCKING FASTENERS PROVIDED! SUBSTITUTING NON-SELF-LOCKING FASTENERS CAN RESULT IN LOOSENING OR SEPARATION OF EQUIPMENT, CAUSING LOSS OF STEERING CONTROL, PROPERTY DAMAGE, PERSONAL INJURY AND OR DEATH. DO NOT EXCEED 110 IN-LB, (12NM) TORQUE ON HELM NUTS AND BOLTS.**

## 5.1.4 EPS Rear Mount Helm (EH1570)

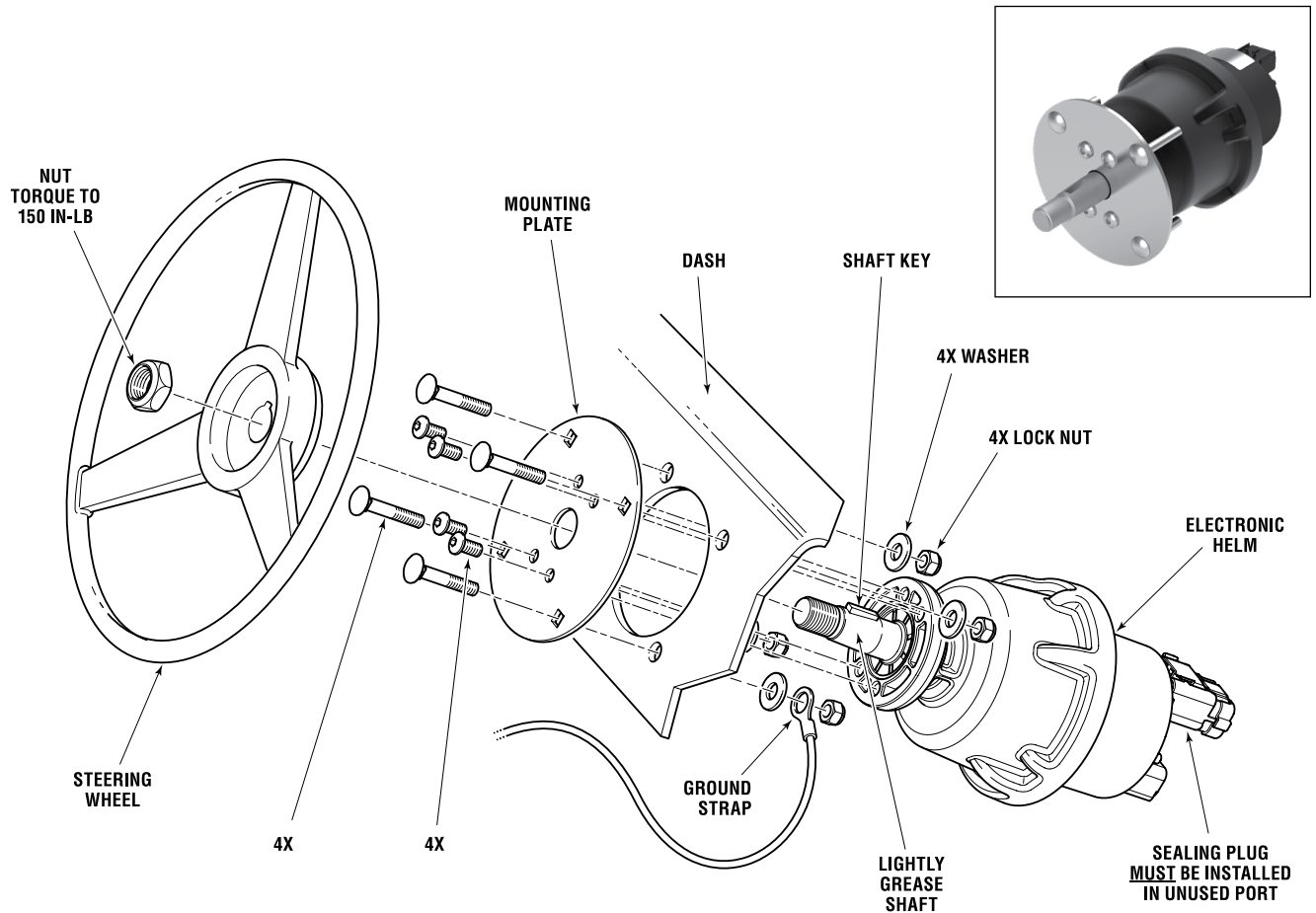

Figure 5-4.

### See Appendix A for Mounting Template

**Install the ground strap** - install one end of the ground strap between the nut and washer on one of the carriage bolts holding the polished plate to the dash. Connect the other end to ground or negative bus bar or to the battery negative terminal.

### **⚠ WARNING**

**USE ONLY THE SELF-LOCKING FASTENERS PROVIDED! SUBSTITUTING NON-SELF-LOCKING FASTENERS CAN RESULT IN LOOSENING OR SEPARATION OF EQUIPMENT, CAUSING LOSS OF STEERING CONTROL, PROPERTY DAMAGE, PERSONAL INJURY AND OR DEATH.. DO NOT EXCEED 110 IN-LB, (12NM) TORQUE ON HELM NUTS AND BOLTS.**

## 5.2 CANtrak Display

Mount the CANtrak display where it is easily visible from the helm station. A mounting template can be found in Appendix A.

### NOTICE

On a dual station vessel the CANtrak is optional at the second station. If you don't install a CANtrak at the second station you must install a buzzer kit (HA5493).

For best results:

- Mount the display vertically, or within 60 degrees of vertical.
- Ensure adequate ventilation around the unit.
- Ensure that you are able to get to the rear of the unit for harness connections.
- **DO NOT** mount parallel to the boat deck, unless the helm is in a completely enclosed wheelhouse where no water can accumulate on the face of the CANtrak.

# DO

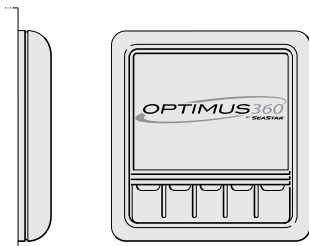

Mount vertical to hull or wall

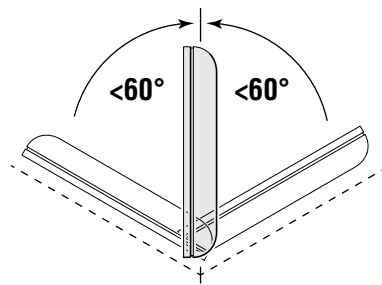

Mount at an angle less than  $60^\circ$

# DO NOT

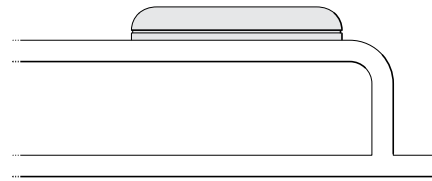

Mount parallel to boat deck

Figure 5-5.

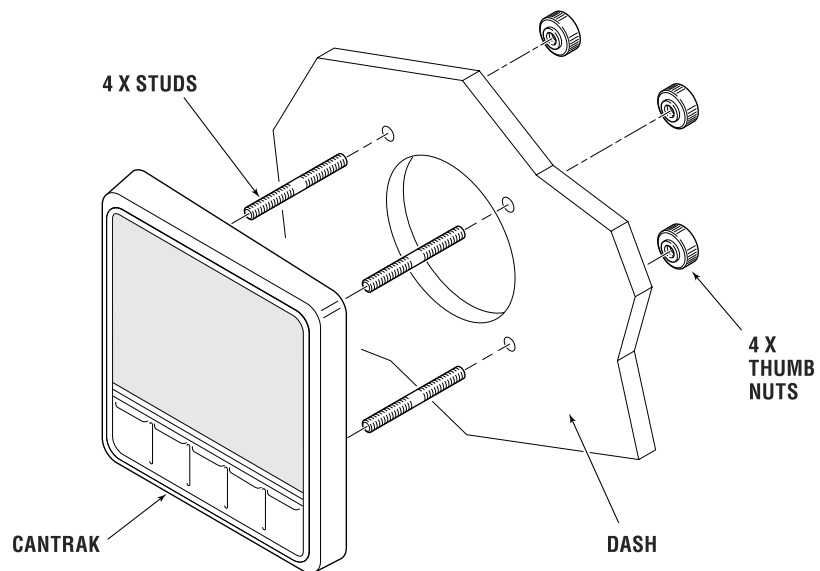

Figure 5-6.



## 5.3 PCM and Power Steering Pumps

PCM and the power steering pumps must be mounted in close proximity. The three foot harnesses on the pumps need to reach the appropriate connectors on the PCM without strain, and they cannot be extended.

**Single Engine Applications:**  
The power steering pump *must* be plugged in to the port pump connection (M1).

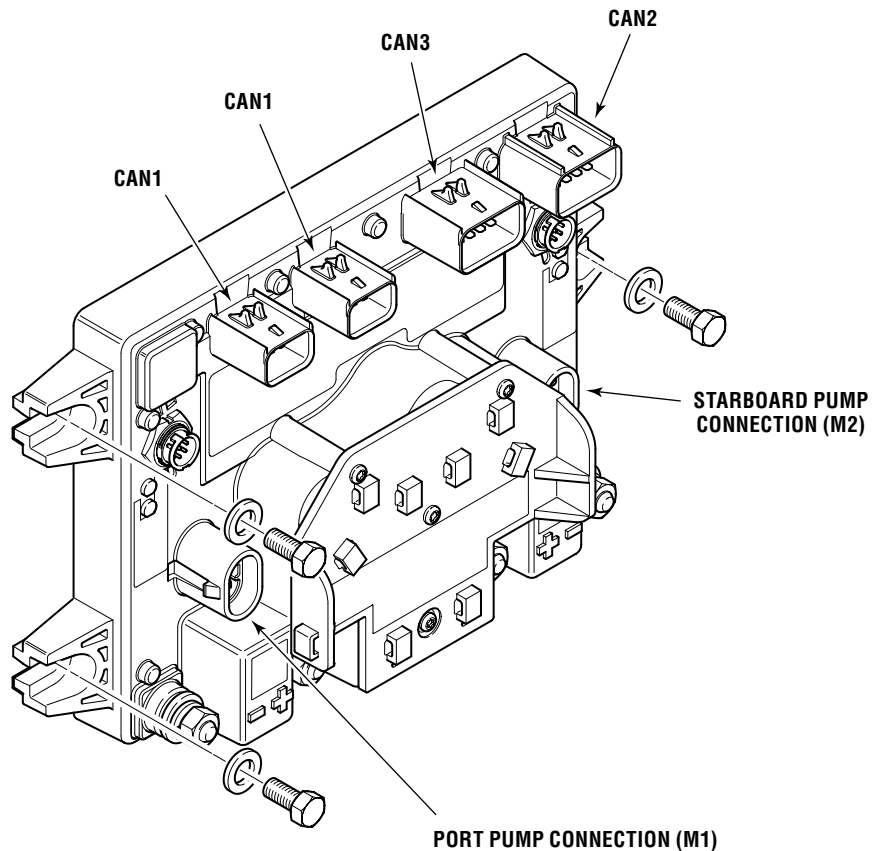

Figure 5-7.

### 5.3.1 PCM Recommended Mounting Hardware

- We recommend that you use only stainless steel mounting hardware.
- Fasten at all three mounting points.
- The PCM is designed to fit 1/4" or M6 cap screws or machine screws. Use washers between the screw head and the PCM.
- Through-bolt with nuts and washers on the back the side, or drill and tap into a metal mounting surface.
- You can also use a #14 wood screw and washer.

### 5.3.2 PCM Mounting Considerations

- Mount the PCM to a flat, vertical surface parallel to the wall or hull. It may be mounted no more than 15 degrees from vertical.
- The PCM must be mounted in a cool, dry location.
- Any unused connectors must have a sealing plug installed.

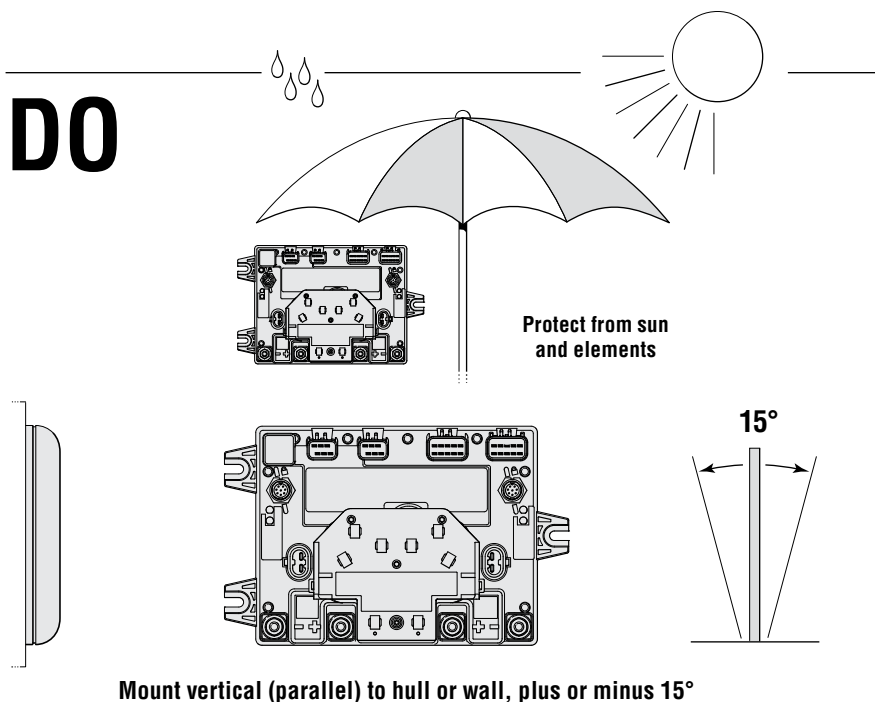

### DO NOT

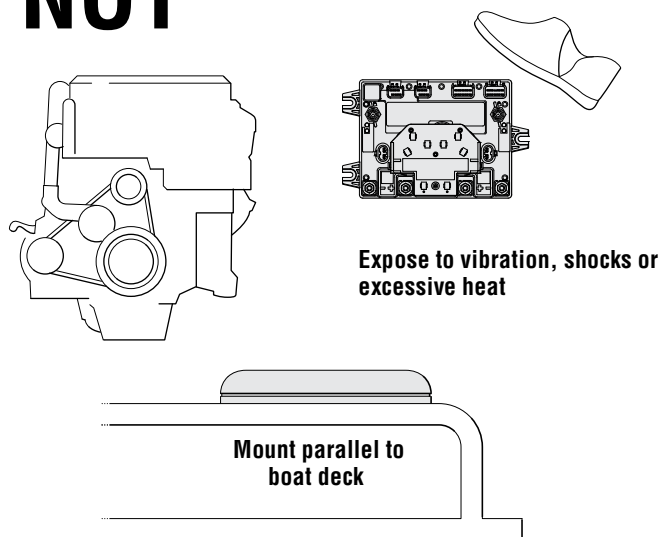

Figure 5-8.

### 5.3.3 Power Steering Pump Mounting Considerations

- Pumps should be mounted in a cool, dry, well ventilated location.
- Pump harnesses are 3' long and must NOT be extended. Choose pump and PCM mounting locations accordingly.
- Pumps can be wall or floor mounted. See Appendix A for mounting dimensions.
- Pumps must be mounted so that the oil level indicators and the well are not only visible, but available to the operator.
- The service valve knob must be easily accessible. Ensure there is room around the knob for a user to grasp it and turn it.
- Pump ports are color coded from the factory to indicate the appropriate cylinder fitting connection.
- Pump ports and corresponding cylinder ports are also marked with "U" and "D."

#### NOTICE

Hose fittings can be relocated to plugged ports if required. (See figure 4-9, item 1 and 2.) Torque hose fittings to 18 ft-lb (24 Nm) and plugs to 50 in-lb (6 Nm).

You can also install 90° fittings (Kit # HF6004) for additional hose routing flexibility.

#### NOTICE

Due to material variability, fitting installation torque differs between the power steering pump and the steering cylinder. Be sure to use the correct installation torque to avoid irreparable damage to the pump housing or cylinder body when installing an ORB fitting.

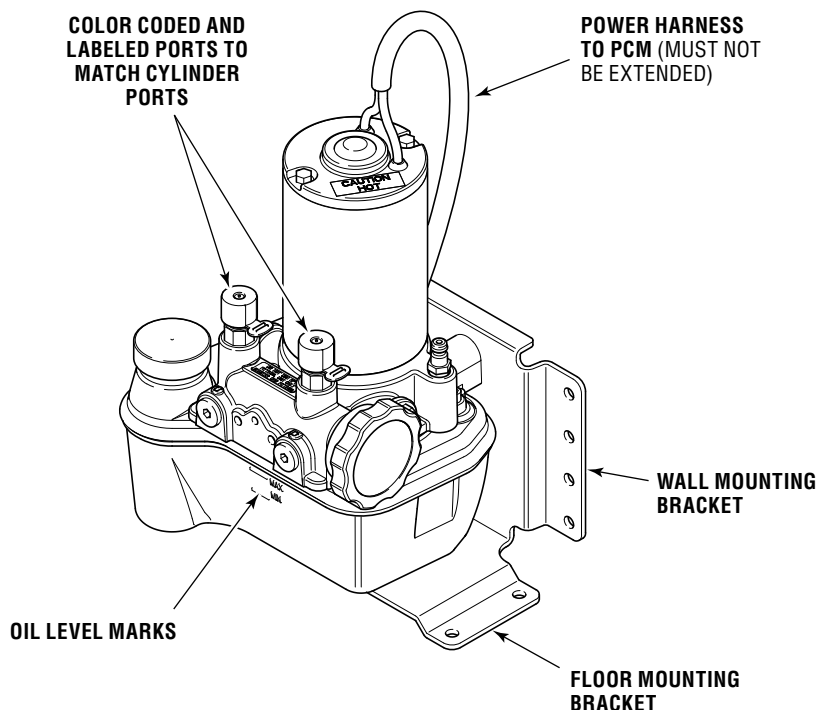

Figure 5-9.

#### ⚠ WARNING

**THE PUMP MOTOR MAY BE HOT TO THE TOUCH DURING OPERATION. DO NOT MOUNT PUMPS IN AN AREA WHERE FABRICS AND/OR OTHER FLAMMABLE MATERIAL MAY COME IN CONTACT WITH THE PUMP MOTOR. DO NOT COVER.**

**DO**

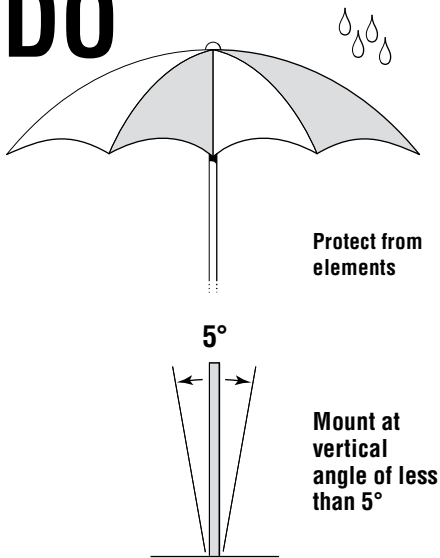

Figure 5-10.

**Note: if wall-mounting the power steering pump:**

- Pumps must be mounted upright to facilitate oil fill and purge.
- If mounting to an angled wall, use shims to mount the pump upright. If you are mounting to a 12° transom, use wedge kit HA5485.

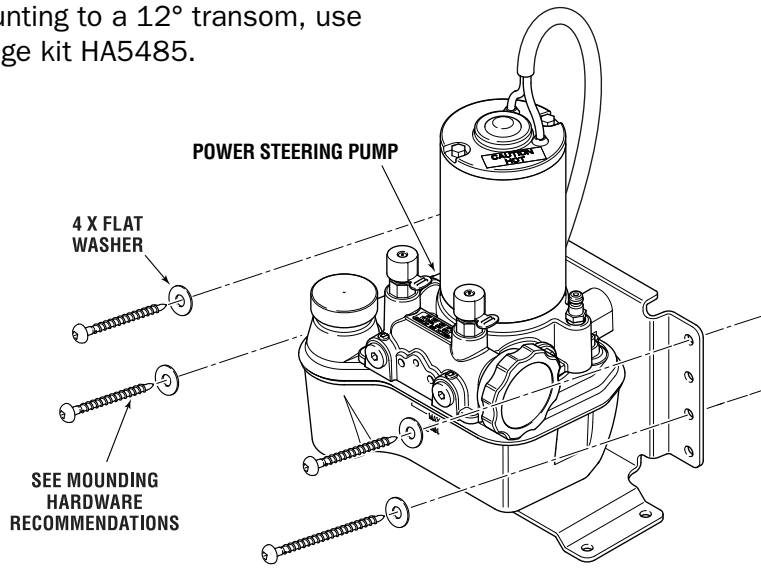

Figure 5-11.

**Note: if floor-mounting the power steering pump:**

- Pumps must be mounted upright to facilitate oil fill and purge.

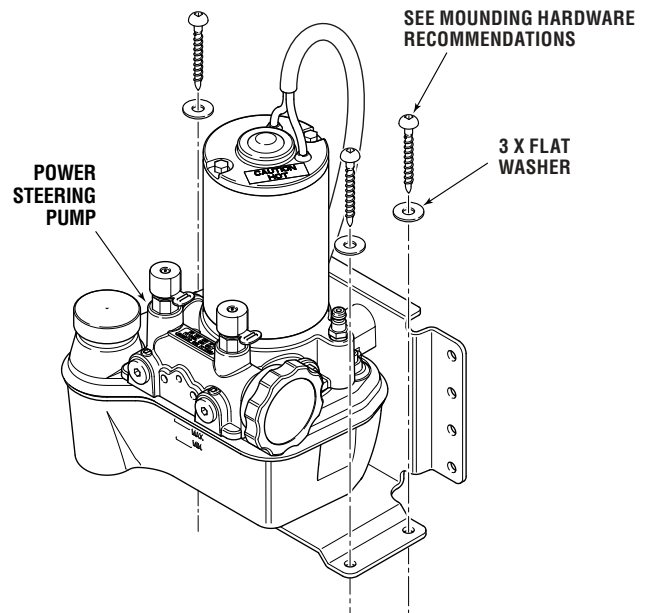

Figure 5-12.

### 5.3.4 Integrated Steering Service Valve

---

The power steering pump has an integrated service valve for maintenance and emergency use. It must be accessible to the operator. If it isn't accessible, you will need to use the remote-mount service valve kit, HA5480.

There is an instruction label on the pump motor. If it is not visible, you must install the label shown in figure 5-13 in a visible location.

**This decal MUST be visible!**



*Figure 5-13.*

### 5.3.5 Power Steering Pump Mounting Hardware

---

Recommended Mounting Hardware:

- M6 cap or machine screw and washer
- 1/4" cap or machine screw and washer
- #14 wood screw and washer (flat bearing surface under screw head only)

## 5.4 SmartCylinder Mounting

### NOTICE

Before beginning installation make sure that all mounting hardware is available and the tiller arm and the tilt tube bolt holes are clean and free from rust or burrs.

Assembly drawings for specific engine applications can be found on page 5-14 through page 5-17 of this manual.

### NOTICE

If your engine application is such that interference will occur if the SmartCylinder is moved throughout its full stroke, leave the SmartCylinder support brackets off for purge and calibration.

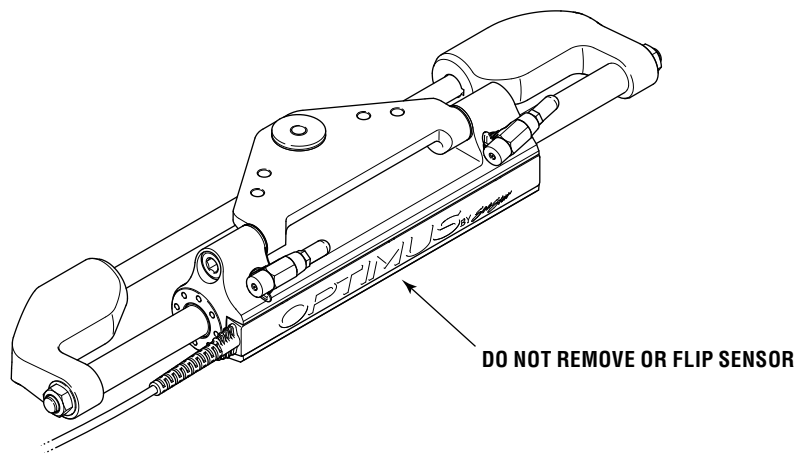

Figure 5-14.

Sensor harness MUST be properly secured to hoses (see Section 5.7).

### ⚠ WARNING

**IF THE ENGINE MANUFACTURER HAS INSTALLED CAPS, PLUGS AND/OR SCREWS INTO THE TILLER ARM, THESE CAPS, PLUGS AND/OR SCREWS MUST BE REMOVED PRIOR TO CONTINUING ON WITH INSTALLATION.**

1. Using an approved quality marine grease (such as Johnson/Evinrude triple guard, Quicksilver anti-corrosion, Yamaha marine grease or equivalent), liberally lubricate the tilt tube and support rod (Item 9) and slide the support rod through the engine tilt tube.
2. Lightly grease the tiller bolt (Item 2) & partially screw into appropriate hole in the tiller arm to assure a proper fit. Then remove the tiller bolt and go to Step 3.
3. Select appropriate insert diagram from page 5-14 through page 5-17 to determine proper orientation of the SmartCylinder assembly, the tiller bolt and self locking nut (Items 13, 2 and 1). Grease tiller bolt as indicated and fully thread tiller bolt (Item 2) into the steering arm. While holding the head of the tiller bolt with a wrench, tighten the tiller nut (Item 1) to the specified torque.

**⚠ WARNING**

**IT IS HIGHLY RECOMMENDED THAT THE TILLER BOLT HEAD IS HELD IN PLACE WITH A WRENCH WHILE THE TILLER NUT IS TORQUED TO THE PROPER SPECIFICATION. FAILURE TO DO SO MAY RESULT IN LOSS OF STEERING CONTROL CAUSING PROPERTY DAMAGE, PERSONAL INJURY AND/OR DEATH.**

4. a) Screw the adjusting nut (Item 10) onto tilt tube. b) Place the stainless washers (Item 11) and the plastic spacers (Items 7 & 8) on the support rod.

**⚠ WARNING**

**REFER TO THE SPECIFIC APPLICATION FIGURE FOR PROPER ORIENTATION OF SPACERS ON BOTH SIDES OF THE ENGINE TILT TUBE.**

5. Attach and secure the support brackets (Item 12) to the support rod and the cylinder shaft. Tighten using the nuts, bolts and washers (Items 3, 4, 5 & 6) as illustrated in application figures.
6. Eliminate the free play in the support rod by turning the adjusting nut (Item 10) counter clockwise until snug. Never use a wrench on the adjusting nut. Always hand tighten. Lock the adjusting nut in place by tightening the Hexagon set screw.

**⚠ WARNING**

**REFER TO PAGE 5-14 THROUGH PAGE 5-17 FOR THE CORRECT TORQUE SPECIFICATIONS FOR THE APPROPRIATE INSTALLATION. FAILURE TO CORRECTLY INSTALL THE SMARTCYLINDER AND TORQUE ALL SCREWS MAY RESULT IN STEERING FAILURE, WHICH COULD RESULT IN PROPERTY DAMAGE, PERSONAL INJURY AND/OR DEATH.**

ENGINE MANUFACTURER	YEAR	MODEL	CYLINDER*	NOTE
<b>MERCURY</b>	1990 TO DATE	75-250 HP	EC5310 or EC6810	
	2002 TO DATE	250SX & 300XS	EC5310 or EC6810	
	2002 TO DATE	90-225 HP Optimax	EC5310 or EC6810	
	2002 TO DATE	90-200 HP Verado	EC5310 or EC6810	

**CAUTION**

Use plastic spacer to ensure there is no metal to metal contact

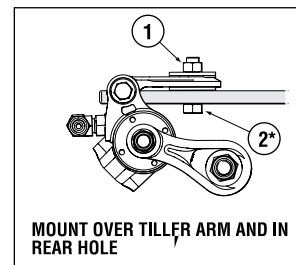

**G** = GREASE POINT

**T** = TORQUE POINT

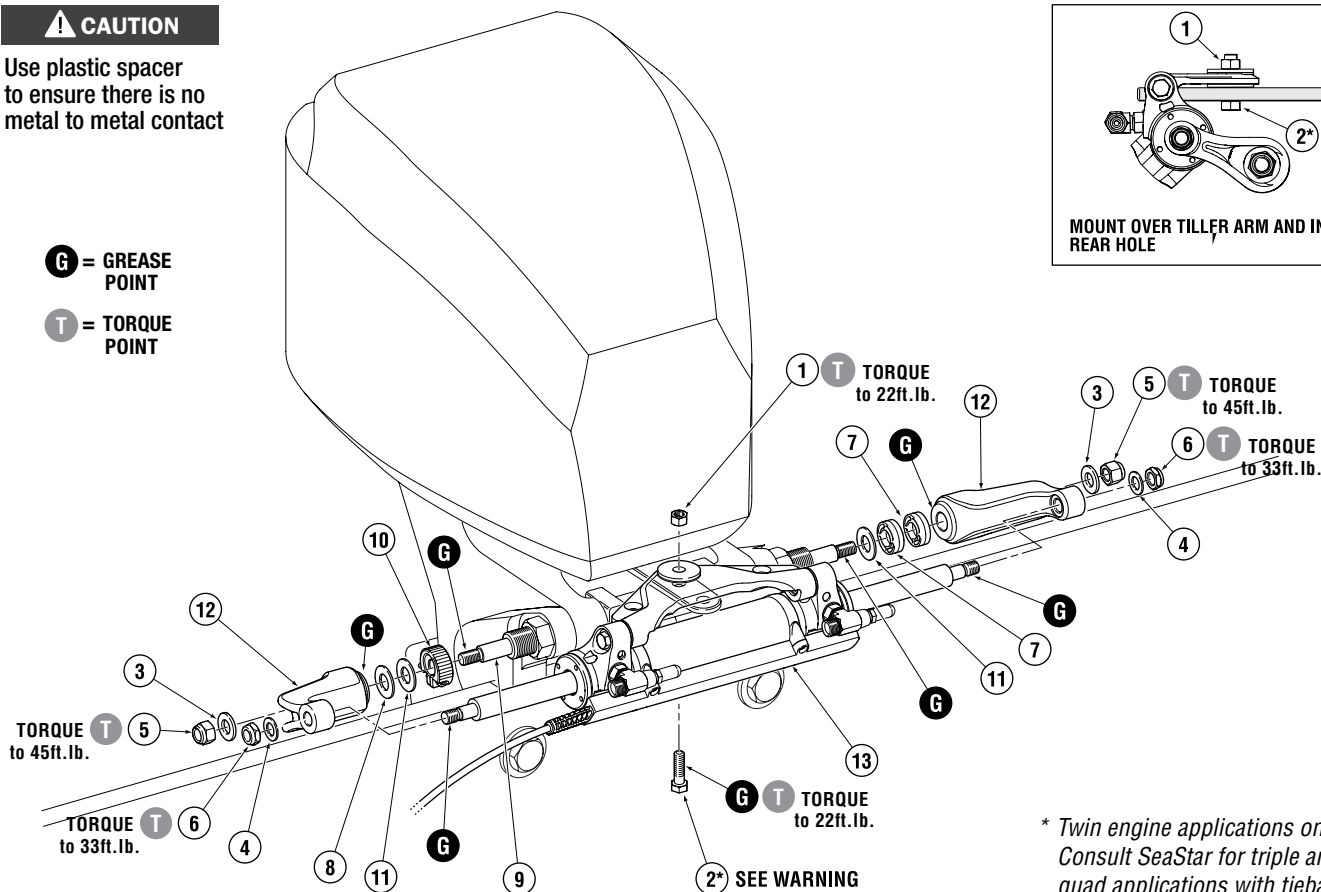

\* Twin engine applications only. Consult SeaStar for triple and quad applications with tiebars.

Figure 5-15.

ITEM	PART #	QTY	DESCRIPTION
*1	113529	1	Nut, 3/8" NF Nylok® SS
*2	113225	1	HHCS 3/8" UNJF x 1.35" HSS
3	731625	2	Washer Flat, 7/16" SS
*4	731720	2	Nut, 7/16" NF Nylok® SS
5	202027	2	Washer, Flat 1/2" SS
*6	192126	2	Nut 1/2" NF Nylok® NI Plate Br
7	995876	2	Spacer, Thick
8	996689	1	Spacer, Thin

ITEM	PART #	QTY	DESCRIPTION
9	730229	1	Support Rod
10	828085	1	Adjusting Nut & Screw SS, Teflon Coated
11	202300	2	Washer, Flat 5/8" SS
12	839120	2	Support Brackets
13	907099	1	Pivot Mount Cylinder
14	728994	1	Space, Medium (Not Used)
15	113350	1	HHCS 3/8" NF x 1-1/2" SS



ENGINE MANUFACTURER	YEAR	MODEL	CYLINDER*	NOTE
JOHNSON/EVINRUDE	2007 TO DATE	3.3L V6 200-250 HP 3.4L V6 250H.O-300 HP	EC5340 or EC6810 EC5340 or EC6810	

**CAUTION**

Use plastic spacer to ensure there is no metal to metal contact

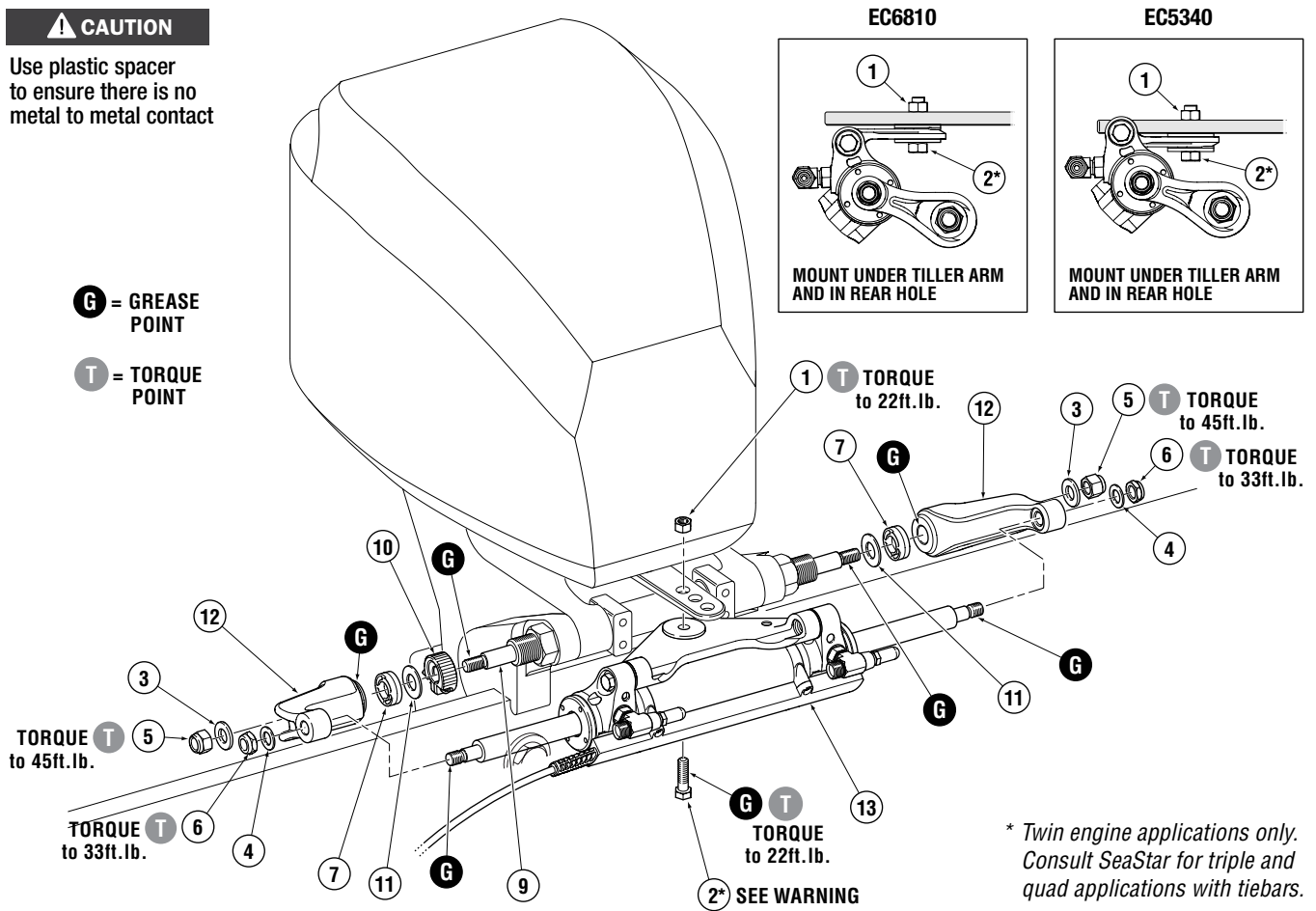

Figure 5-16.

ITEM	PART #	QTY	DESCRIPTION
*1	113529	1	Nut, 3/8" NF Nylok® SS
*2	113225	1	HHCS 3/8" UNJF x 1.35" HSS
3	731625	2	Washer Flat, 7/16" SS
*4	731720	2	7/16" NF Nylok® SS
5	202027	2	Washer, Flat 1/2" SS
*6	192126	2	Nut 1/2" NF Nylok® NI Plate Br
7	995876	2	Spacer, Thick, Plastic
8	996689	1	Spacer, Thin, Plastic

ITEM	PART #	QTY	DESCRIPTION
9	730229	1	Support Rod
10	828085	1	Adjusting Nut & Screw SS, Teflon Coated
11	202300	2	Washer, Flat 5/8" SS
12	839120	2	Support Brackets
13	907099	1	Pivot Mount Cylinder
14	728994	1	Spacer, Medium (Not Used)
15	113330	1	HHCS, 3/8" NF x 1-3/8" SS

ENGINE MANUFACTURER	YEAR	MODEL	CYLINDER*	NOTE
<b>YAMAHA</b>	2007 TO DATE	F300-350 HP 5.3 V8	EC5310 or EC6810	(SEE BELOW)
	2007 TO DATE	350 HP (see note below)	EC5310 or EC6810	(SEE BELOW)
<b>HONDA</b>	2001 TO 2009	150-225 HP 4 STROKE	EC5310 or EC6810	(SEE BELOW)
	2010 TO DATE	115 HP	EC5310 or EC6810	(SEE BELOW)
<b>SUZUKI</b>	1986 TO DATE	150-300 HP	EC5340 or EC6840	(SEE BELOW)

**CAUTION**

Use plastic spacer to ensure there is no metal to metal contact

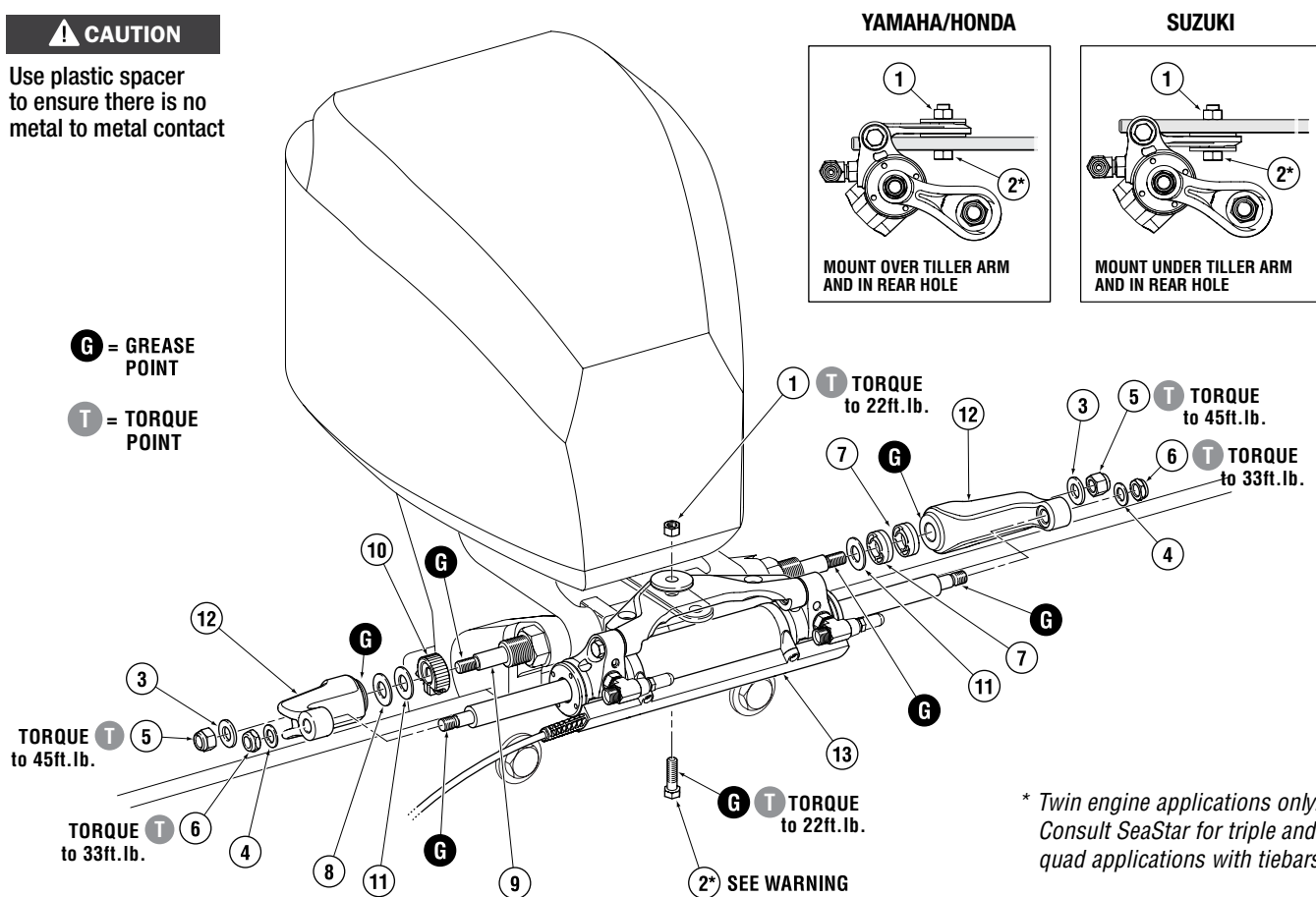

Figure 5-17.

ITEM	PART #	QTY	DESCRIPTION
*1	113529	1	Nut, 3/8" NF Nylok® SS
*2	113225	1	HHCS 3/8" UNJFX 1.35 HSS
3	731625	2	Washer, Flat, 7/16" SS
*4	731720	2	Nut, 7/16" NF Nylok® SS
5	202027	2	Washer, Flat, 1/2" SS
*6	192126	2	Nut, 1/2" NF Nylok® NI Plate Br
7	995876	2	Spacer, Thick
8	996689	1	Spacer, Thin

ITEM	PART #	QTY	DESCRIPTION
9	730229	1	Support Rod
10	828085	1	Adjusting Nut & Screw, SS, Teflon Coated
11	202300	2	Washer, Flat, 5/8" SS
12	839120	2	Support Brackets
13	907099	1	SmartCylinder (EC5310) or
	907033	1	SmartCylinder (EC5340)
14	728994	1	Spacer, Medium (some 1996 to 1998)
15	113350	1	HHCS 3/8" NF x 1-1/2" SS

## 5.4.1 Ground Strap Installation

### NOTICE

FOR SALT WATER APPLICATIONS

SeaStar Solutions strongly recommends use of a ground strap on any outboard hydraulic steering cylinder with an exposed shaft where the vessel will be used in salt water. This ground strap will provide added protection against corrosion caused by stray current.

- Install ground strap to cylinder on **opposite** side from Rudder Reference Unit cable exit as per Figure 5-18.
- Install cylinder and support rod nuts, torque to the following
  - i) cylinder shaft nut = 33 ft.lb.
  - ii) support rod shaft nut = 45 ft.lb.
- Route ground strap UNDER the tilt tube and attach loose end of strap to the port side lower midsection steering bracket bolts using the correct fasteners.
- Ensure there is enough slack in the strap to allow the engine to pivot freely in ALL trim/tilt positions and throughout the entire steering range of the engine.

### CAUTION

Ensure ground strap is routed 'under' the tilt tube. Installation of the strap 'above' the tilt tube may lead to a hang up, or restriction.

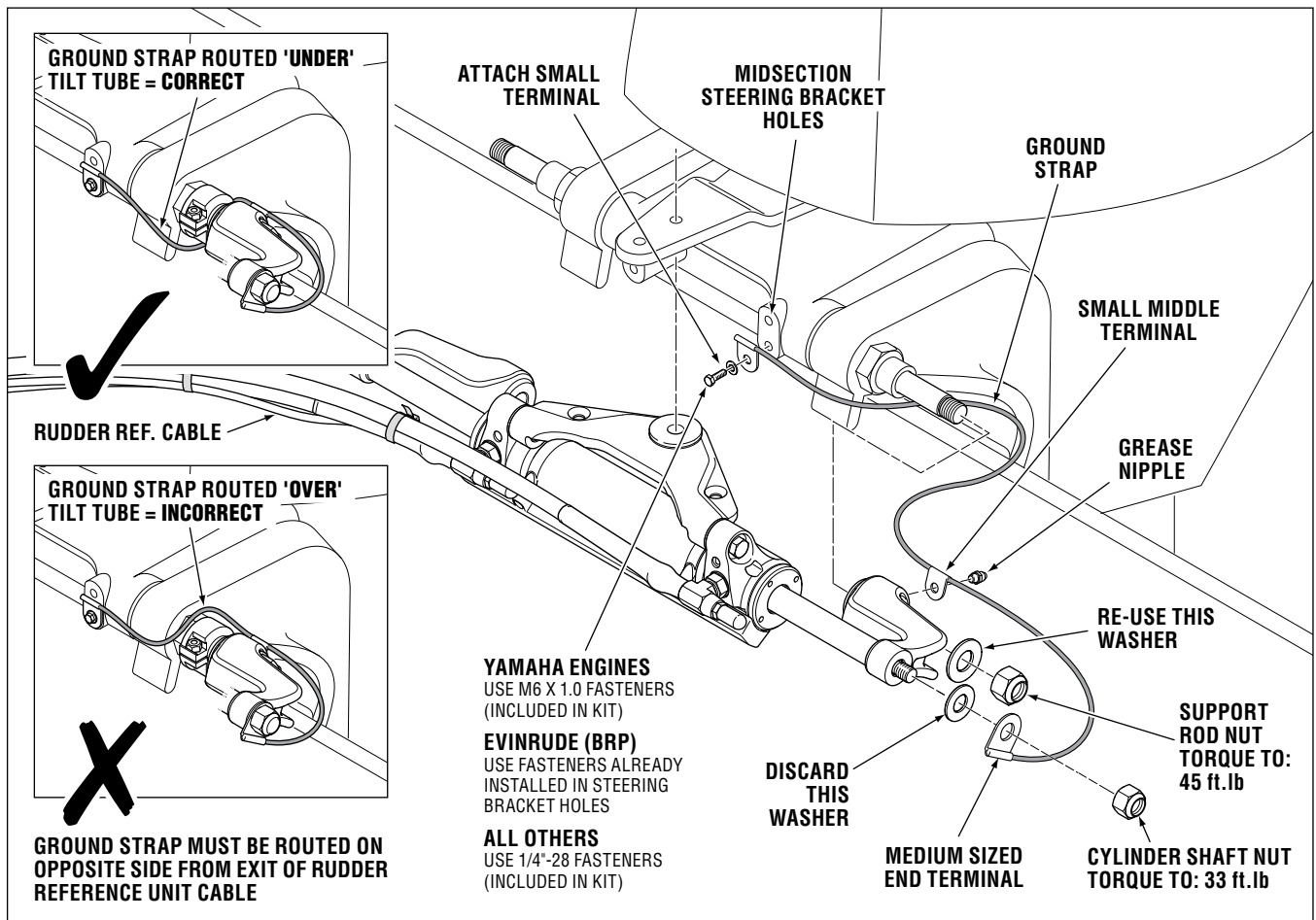

Figure 5-18.

## 5.5 Plumbing the System

### ⚠ WARNING

**THE OPTIMUS EPS SYSTEM REQUIRES THE USE OF SEASTAR PRO (1500 PSI) KEVLAR REINFORCED HOSES ONLY.**

### ⚠ WARNING

**DO NOT CUT SEASTAR PRO STEERING HOSE. THERE IS NO MEANS IN THE FIELD TO INSTALL A SWAGE FITTING TO THE HOSE END.**

### ⚠ CAUTION

**Substituting brass fittings into the steering cylinder may result in galvanic corrosion and irreparable damage to the cylinder as well as affect system integrity.**

### NOTICE

*Individual items (i.e. swage fitting, bulkhead plate, hose, etc.) cannot be ordered as a single part. If replacement parts are required an entire new length of hose will need to be purchased.*

Before continuing with the installation of the steering hoses, please ensure that you read and understand the important points listed below:

- **DO NOT** install any pipe sealant onto the “hose” side of a fitting.
- **DO NOT** remove protective end covers until the hoses have been routed and are ready to be connected to the pump or steering cylinder(s).
- Before, during and after installation the hoses **MUST** be protected from chafing, rubbing, and contact or interference with assembly screws or sharp edges of any type.
- **DO NOT** install hoses in an area where they will be exposed to high heat, such as engine manifolds, engine compartments or highly corrosive areas such as battery fumes or electrical connections.
- If possible, route hoses through a protective PVC cover.
- Secure hoses in 1ft. (31 cm) or smaller increments.
- **DO NOT** bend hoses tighter than a 3-1/2” (89 mm) radius.
- Provide sufficient hose lengths to allow for cylinder movement throughout the turning arc and UP/DOWN trim/tilt settings of the engine(s).
- **DO NOT** allow hoses to hang free in an area where they could become a safety hazard.
- **DO NOT** use extruded nylon tubing for plumbing an Optimus EPS Steering system.
- Where possible, route hoses in an area where they can be easily inspected for wear on a regular basis.

## **⚠ WARNING**

**CONTINUOUS KINKING, RUBBING, CHAFING OR TWISTING OF A STEERING HOSE MAY EVENTUALLY WEAKEN THE HOSE(S) TO A POINT WHERE IT COULD RUPTURE, CAUSING LOSS OF STEERING CONTROL, PROPERTY DAMAGE, PERSONAL INJURY AND OR DEATH.**

### **5.5.1 Hose Labels**

When plumbing the Optimus EPS system it is extremely important to get all of the connections in the correct place. When the hoses are being pulled through the boat it is easy to lose track of which hoses are which. To assure proper connections each kit is supplied with a sheet of labels that **MUST** be used to identify each hose end. Attach the labels to the hoses **BEFORE** routing the hoses in the boat.

The sheet also contains labels to identify the port and starboard power steering pumps, service valves (if remote valves are used), and SmartCylinder cables. Place all labels so they can be easily read after the installation is complete as they are a great help when servicing the system. See illustration below.

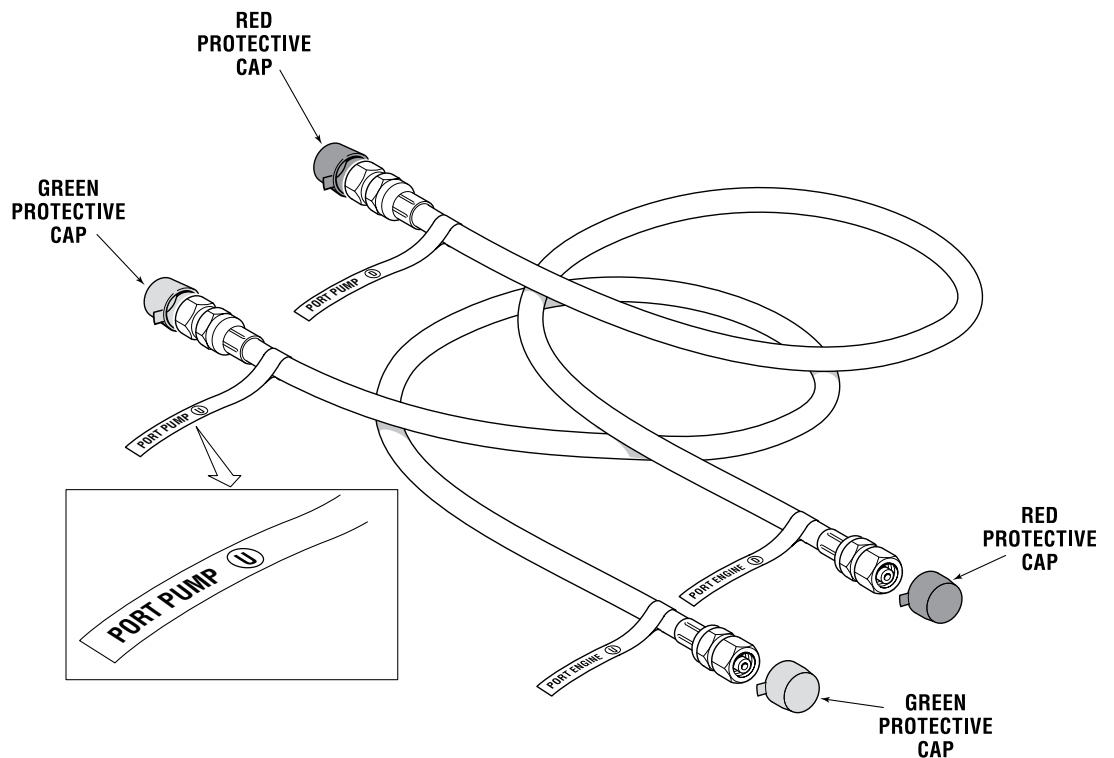

Figure 5-19.

## 5.5.2 Hose Installation

Figure 5-20 shows the general plumbing diagram for the Optimus EPS system. It is critical that the connections are made correctly, so be sure to pay attention to the port identifiers and the color coded protective caps. Standard hoses are shown for clarity, but the connections are the same for bulkhead hoses.

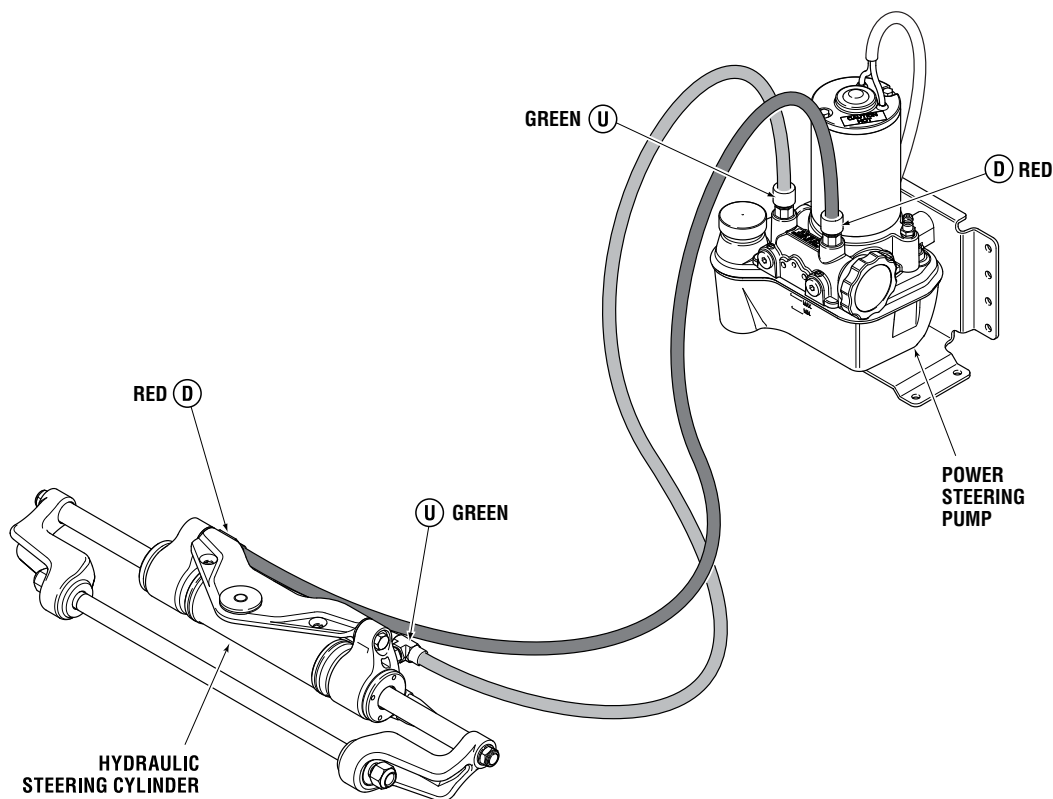

Figure 5-20. Hydraulic connections.

### ⚠ WARNING

**ENSURE THE STARBOARD CYLINDER IS CONNECTED TO THE STARBOARD PUMP, AND THE PORT CYLINDER IS CONNECTED TO THE PORT PUMP. INCORRECT PLUMBING MAY LEAD TO PROPERTY DAMAGE, PERSONAL INJURY AND/OR DEATH.**

### ⚠ CAUTION

**DO NOT** remove the protective end caps until connections are ready to be made.

### NOTICE

- Be sure to mark all hoses using the supplied labels to insure correct installation.
- We recommend you plumb and connect hoses for each engine separately to avoid confusion.

### 5.5.2.1 Bulkhead Hoses

1. Apply hose labels as instructed in Section 5.5.1
2. Determine desired area where the hoses will exit the transom. **DO NOT** mount below the waterline of the boat as this is *not* a fluid tight fitting.
3. Drill two 1" holes in desired location through the bulkhead or splashwell. Clean hole after drilling to ensure it is free of any burrs that may puncture or chafe the steering hose(s).
4. Feed the hoses from the outside of the boat through the splashwell/bulkhead. Note that the bend restrictor (see figure 5-22) must be at the cylinder end of the hose.
5. Secure each bulkhead plate using #10 screws (customer supplied).
6. Attach the hydraulic hoses to the SmartCylinder and slide the bend restrictor over the fitting as shown in figure 5-22. Torque fitting to 15 ft-lb. (20 Nm). If necessary, you can reposition the fitting on the cylinder. See section 5.5.3.
7. Once you are satisfied with the hose routing from the bulkhead plate to the cylinders, thread the pigtail fitting onto the bulkhead mounting plate and torque to 20 in-lb (2.31 Nm).

## ⚠ WARNING

**DO NOT INSTALL BULKHEAD HOSES BELOW THE WATERLINE.**

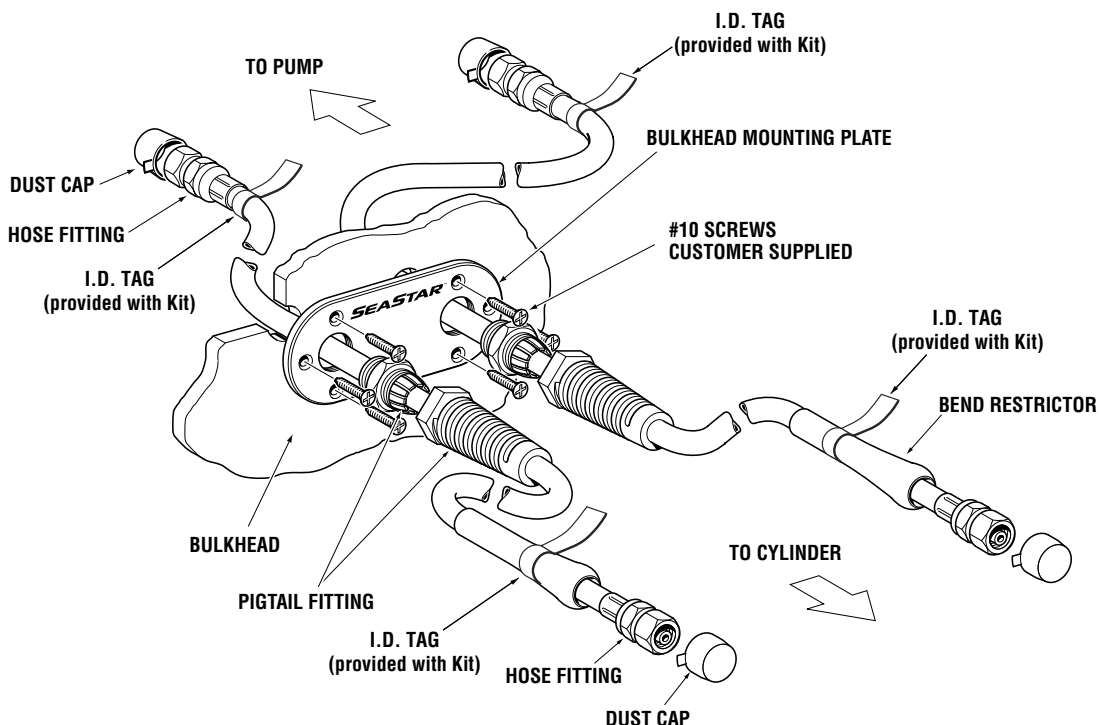

Figure 5-21.

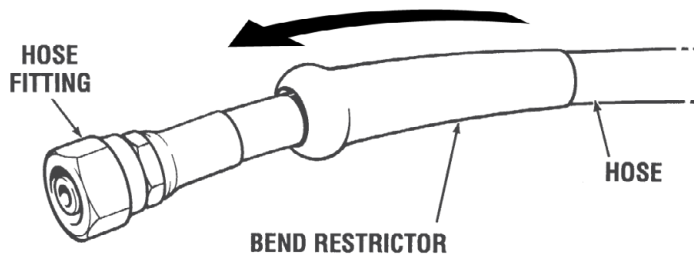

Figure 5-22.

8. Inside the vessel, route the hoses along the gunwale or inside a protective PVC pipe to the power steering pumps. Connect the hoses to the appropriate pump ports and tighten to 15 ft-lb. (20 Nm) The cylinder 'U' and 'D' ports must be connected to the corresponding pump 'U' and 'D' ports.

### 5.5.2.2 Standard Hoses

1. Apply hose labels as instructed in section 5.5.1
2. Feed the hoses from the outside of the boat through the splashwell/bulkhead. Note that the bend restrictor (see figure 5-22) must be at the cylinder end of the hose.
3. Attach the hydraulic hoses to the SmartCylinder and slide the bend restrictor over the fitting as shown in figure 5-22. Torque fitting to 15 ft-lb. (20 Nm). If necessary, you can reposition the fitting on the cylinder. See section 5.5.3.
4. Inside the vessel, route the hoses along the gunwale or inside a protective PVC pipe to the power steering pumps. Connect the hoses to the appropriate pump ports and tighten to 15 ft-lb. (20 Nm) The cylinder 'U' and 'D' ports must be connected to the corresponding pump 'U' and 'D' ports.

### 5.5.3 Hose Fitting Reorientation (if required)

1. Back off lock nut (item 1 in figure 5-23) counter-clockwise, until it stops.
2. Thread fitting into the cylinder port until the fitting washer (item 2) contacts the face of the cylinder port. Tighten hand tight. DO NOT USE A WRENCH.
3. Re-position fitting to desired orientation by turning it counter-clockwise to a MAXIMUM of 1 full turn.
4. While holding the fitting body securely with a wrench, torque the locknut to 40–43ft-lb.



**⚠ WARNING**

**FAILURE TO PROPERLY TIGHTEN THE LOCKNUT MAY LEAD TO LOSS OF STEERING CONTROL. LOSS OF STEERING CONTROL MAY RESULT IN UNPREDICTABLE BOAT BEHAVIOR, COLLISION WITH AN OBSTACLE AND/OR EJECTION FROM VESSEL, LEADING TO PROPERTY DAMAGE, PERSONAL INJURY AND/OR DEATH.**

**NOTICE**

*Due to material variability, fitting installation torque differs between the power steering pump and the steering cylinder. Be sure to use the correct installation torque to avoid irreparable damage to the pump housing or cylinder body when installing an ORB fitting.*

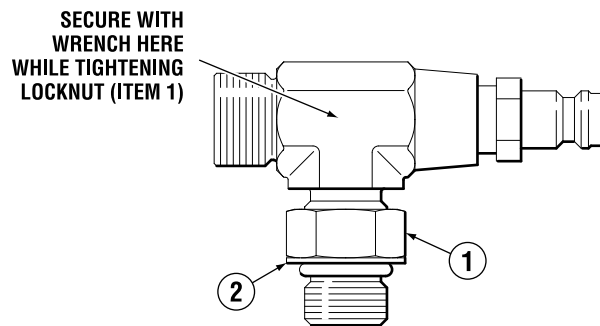

Figure 5-23. Re-orientable hose fitting.

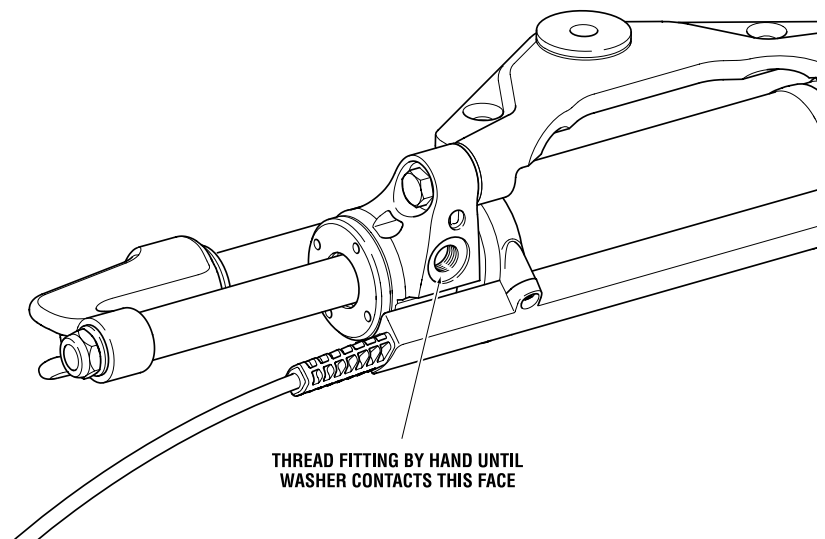

Figure 5-24.

## 5.7 Connecting the SmartCylinder

### NOTICE

Be sure to mark all hoses using the supplied labels to insure correct installation. See Section 5.5.1.

Each SmartCylinder is supplied with and 18 foot (5.5 m) harness. Route the harness for each SmartCylinder as shown below. A Starboard exit harness is preferred, but a Port harness is acceptable if there is a smooth harness bend which is securely tied back to the fitting. Sensor harness MUST be secured to the hydraulic hoses every six inches (15 cm). Harness ends MUST be marked PORT or STARBOARD (on single engine applications mark the harness PORT, as you will be connecting it to the port side of the PCM). **DO NOT** mix up sensor harness connections at PCM. Identification labels are provided with the kit.

### Starboard Cable Installation (preferred method)

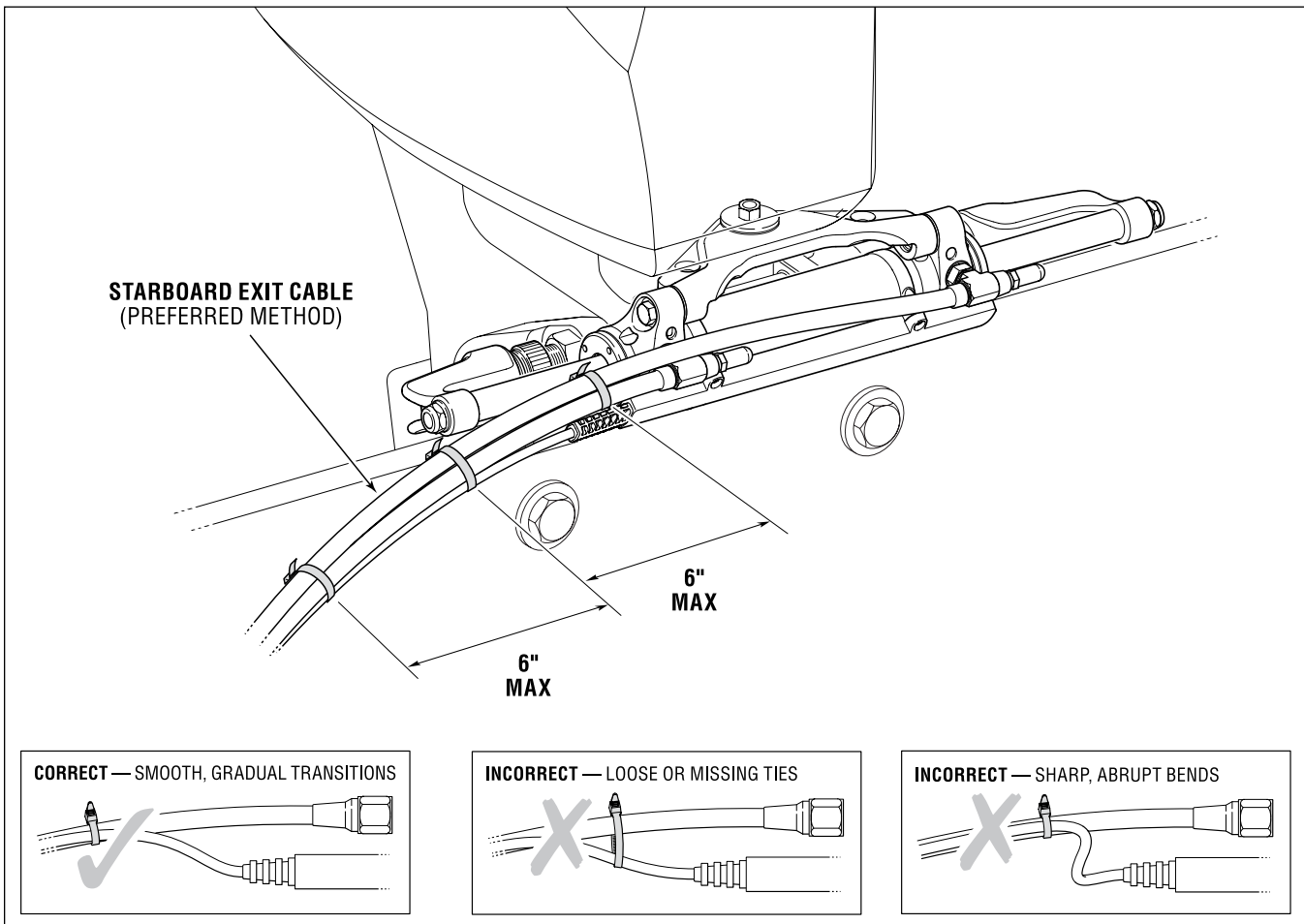

Figure 5-25.

## Port Cable Installation (alternate method)

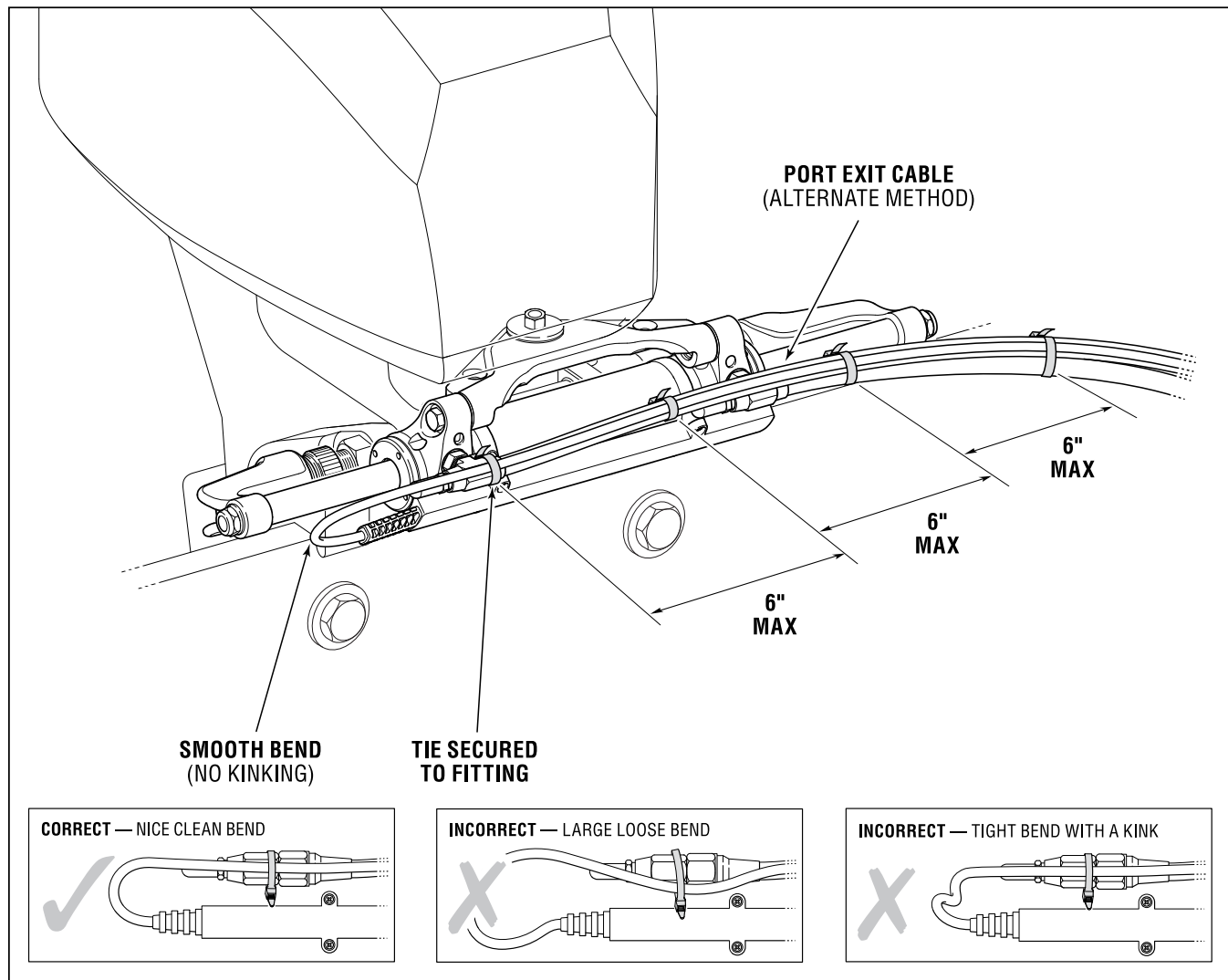

Figure 5-26.

### **⚠ WARNING**

**FAILURE TO SECURE HARNESS MAY RESULT IN HARNESS WEAR, CAUSING LOSS OF STEERING CONTROL, PROPERTY DAMAGE, PERSONAL INJURY AND OR DEATH.**

If additional harness length is required to reach the SmartCylinder, extension harness are available (see Section 4.3.5).

Connect the SmartCylinder harness to the PCM (as shown on page 5-27).

---

### SmartCylinder Harness Bulkhead Installation

If a bulkhead connector is used for a cylinder harness, run the SmartCylinder harness close to the hoses and secure to hoses with cable ties.

The SmartCylinder Harness is supplied with a bulkhead plate pre-installed. The cable end requires a one inch through hole. Position the bulkhead plate close to the hydraulic hose bulkhead plate(s) so that the SmartCylinder harness can be secured to the hoses.

---

### **⚠ WARNING**

**DO NOT INSTALL BULKHEAD HOSES BELOW THE WATERLINE.**

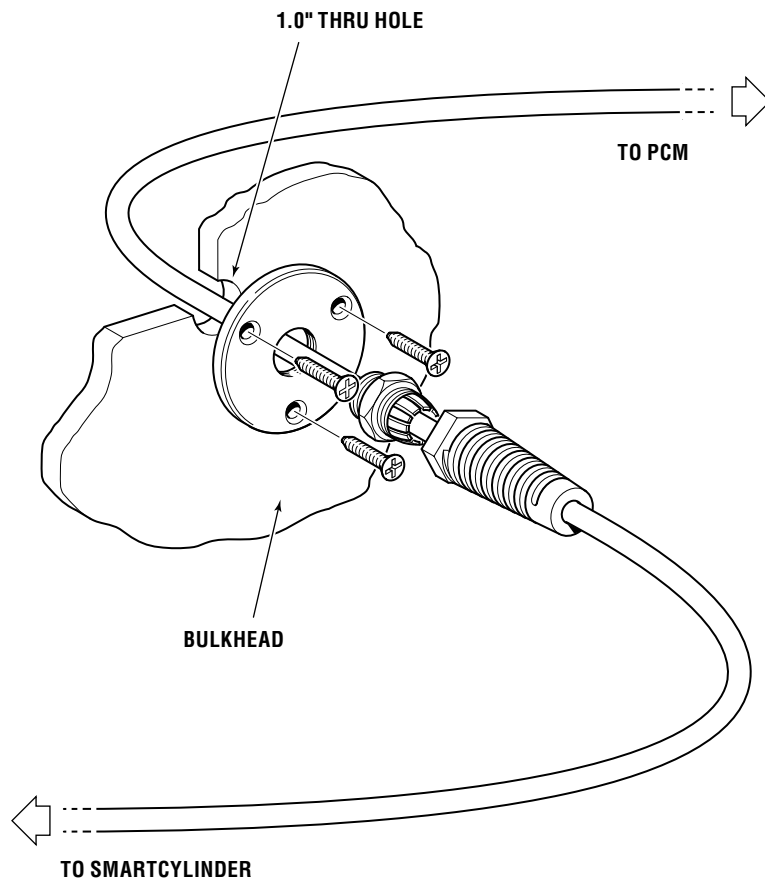

Figure 5-27.

**NOTICE**

SmartCylinder Sensor Harness must be properly locked into the PCM by aligning the alignment marks on the SmartCylinder harness end and the PCM (see detailed view below).

**Single Engine Applications:**  
The sensor harness must be plugged in to the port SmartCylinder connection (RFU1).

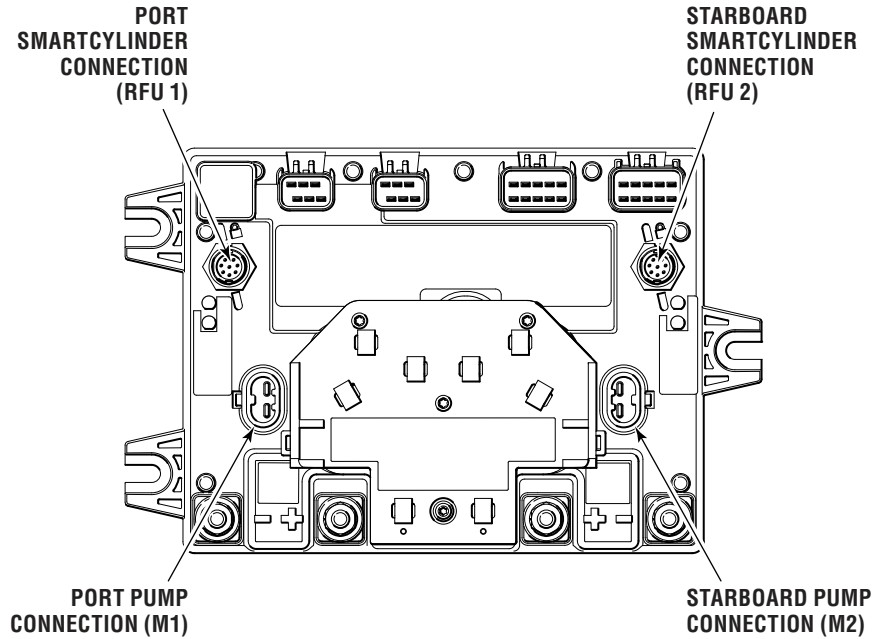

Figure 5-28.

**CAUTION**

**DO NOT** force past the marks shown below.

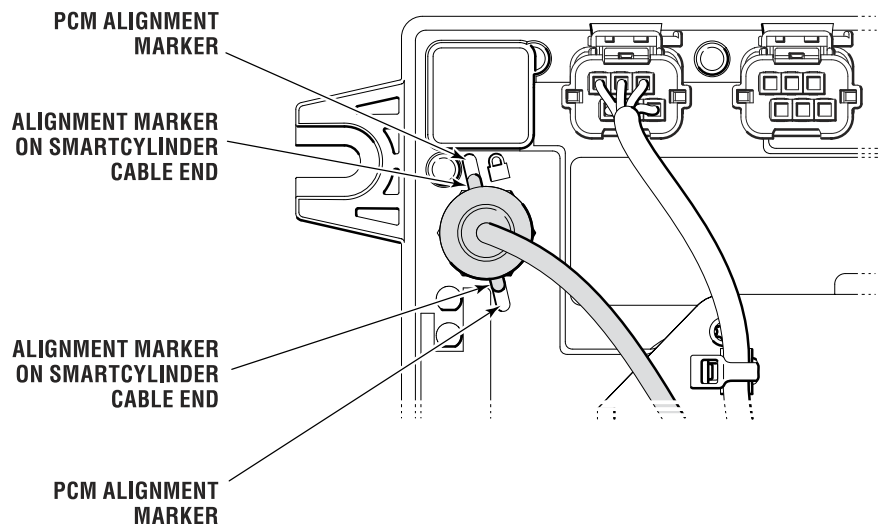

Figure 5-29.

*This page left intentionally blank.*

# 6.0 NETWORKS AND WIRING

## 6.1 Network Diagrams

The following schematics illustrate the CAN1 and CAN2 network connections for single and dual station installations. Connections are made with simple harness connections, as shown in section 6.2.

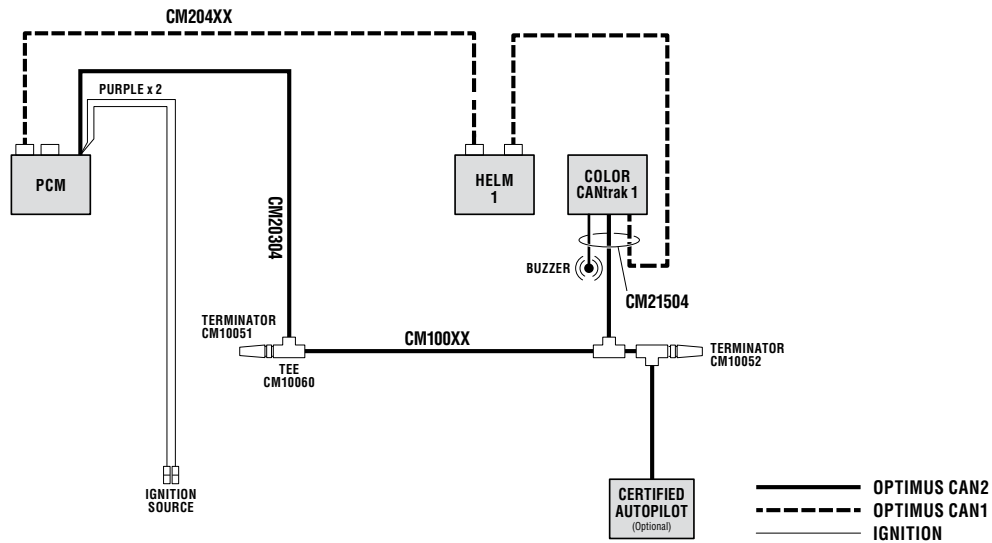

Figure 6-1. Network diagram — single station, multi-engine.

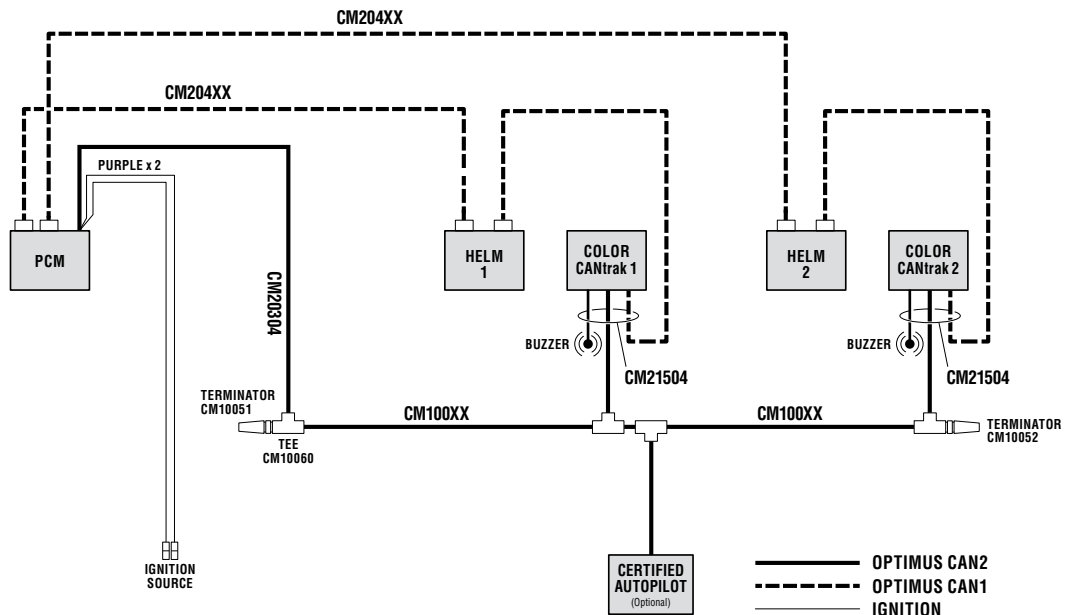

Figure 6-2. Network diagram — dual station, multi-engine.

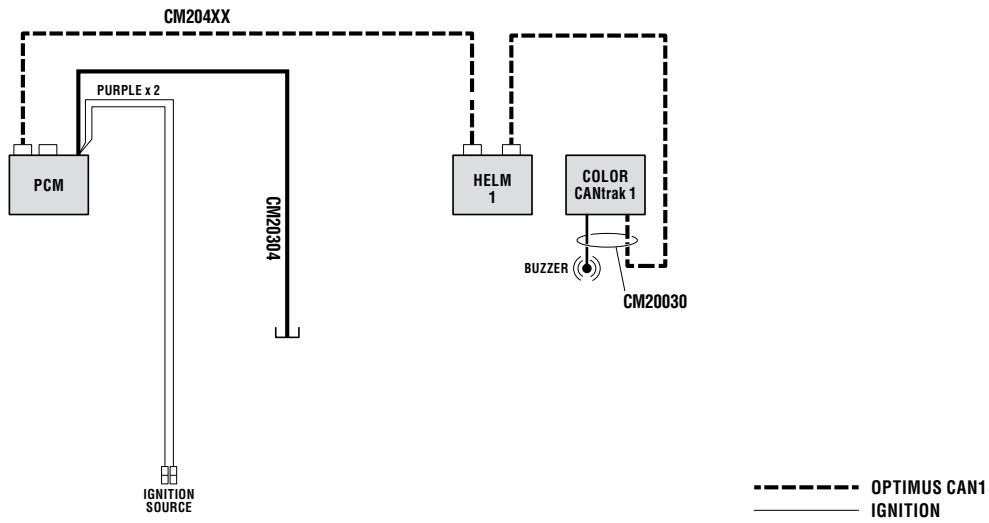

Figure 6-3. Network diagram — single station, single engine.

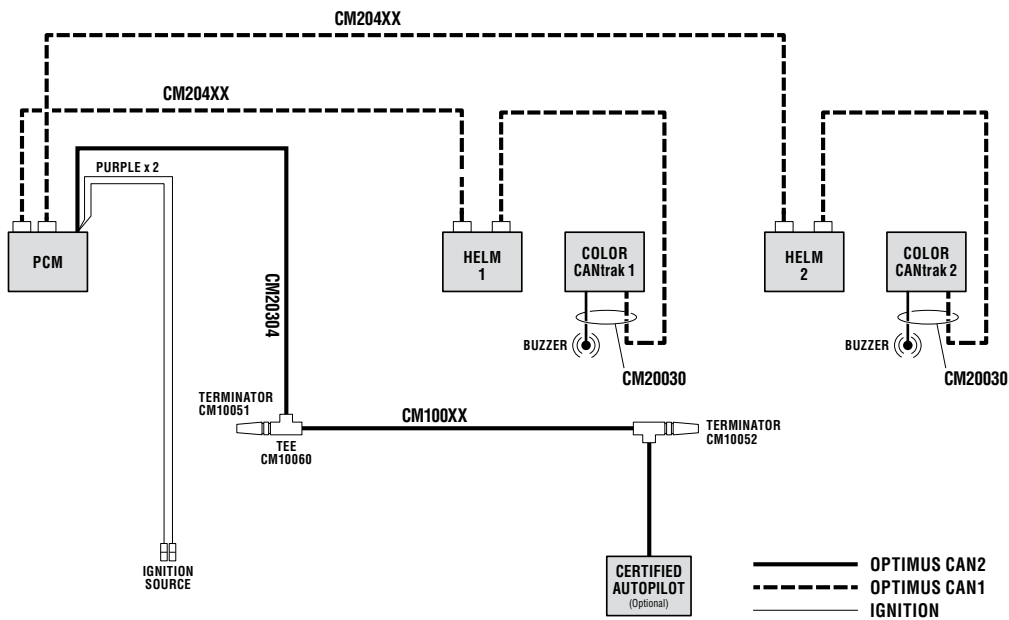

Figure 6-4. Network diagram — dual station, single engine, with optional CAN2 for autopilot.



## 6.2 Harness Connections

### 6.2.1 Connecting the Helm

Connect the Helm to the PCM CAN1, Port 1, using harness CM204XX. For available harness lengths, see Section 4.3.1. Ensure that the cable is strain relieved as shown below.

Note: See the figure on the next page for proper installation of the helm connector.

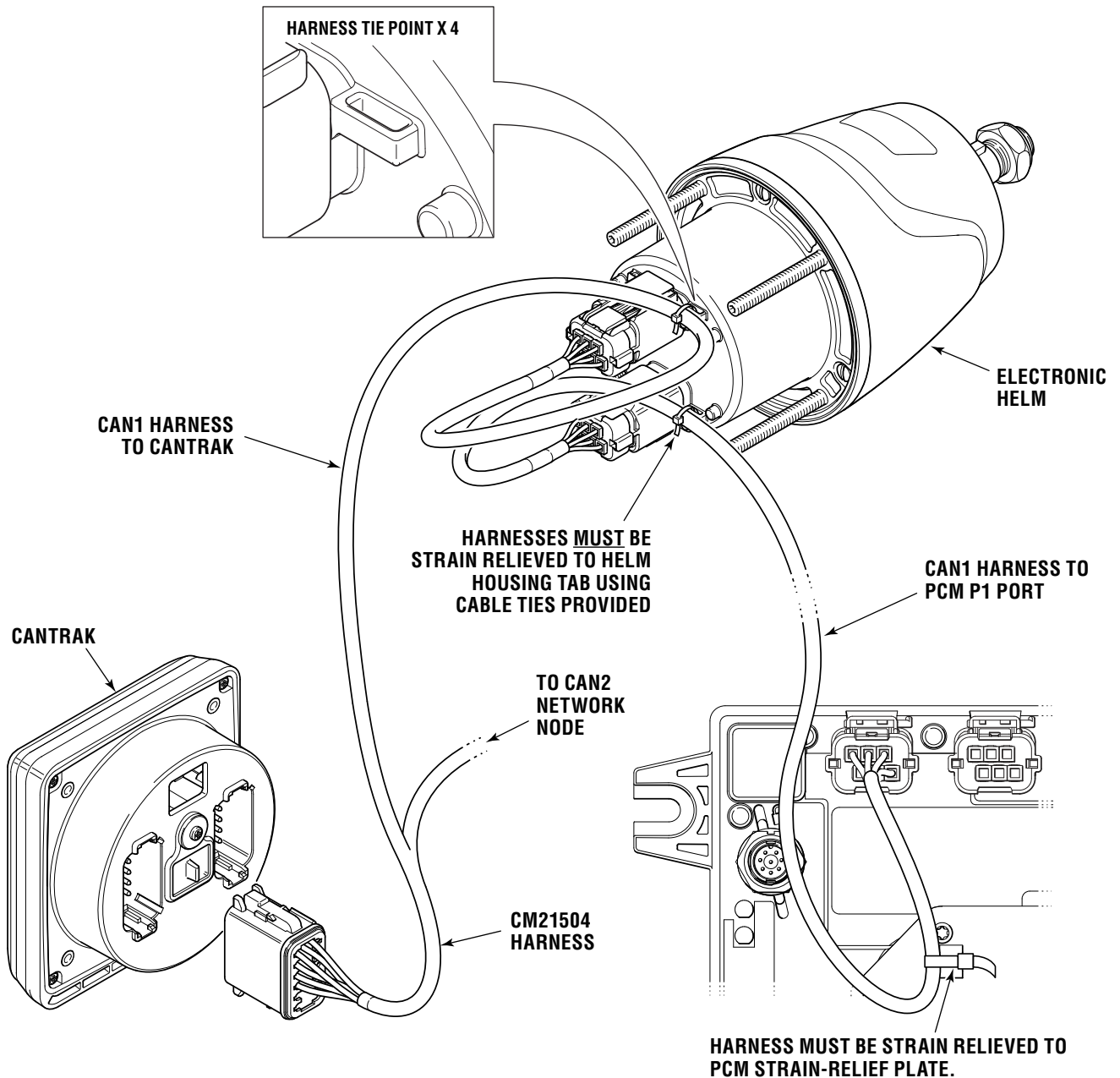

Figure 6-3.

**⚠ WARNING**

**A SEALING PLUG MUST BE INSTALLED IN ANY UNUSED PORTS.**

**⚠ WARNING**

**FAILURE TO SECURE HARNESS MAY RESULT IN HARNESS WEAR, CAUSING LOSS OF STEERING CONTROL, PROPERTY DAMAGE, PERSONAL INJURY AND/OR DEATH.**

To properly install connector, push into the socket, listen for it to click, then push the lock over, as shown below.

**TO LOCK:**

- 1. PRESS THE CONNECTOR FIRMLY ONTO THE RECEPTACLE**
- 2. LISTEN FOR THE "CLICK" AS THE CONNECTOR LOCKS**
- 3. PUSH TO ENGAGE THE SECONDARY LOCK**

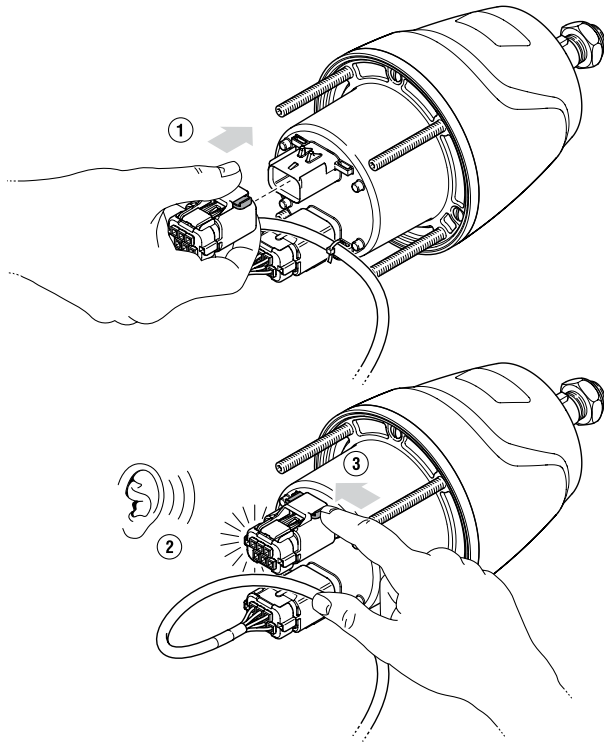

**TO UNLOCK:**

- 1. PUSH TO DISENGAGE THE SECONDARY LOCK**
- 2. SQUEEZE TO UNLATCH THE CONNECTOR**
- 3. PULL TO REMOVE**

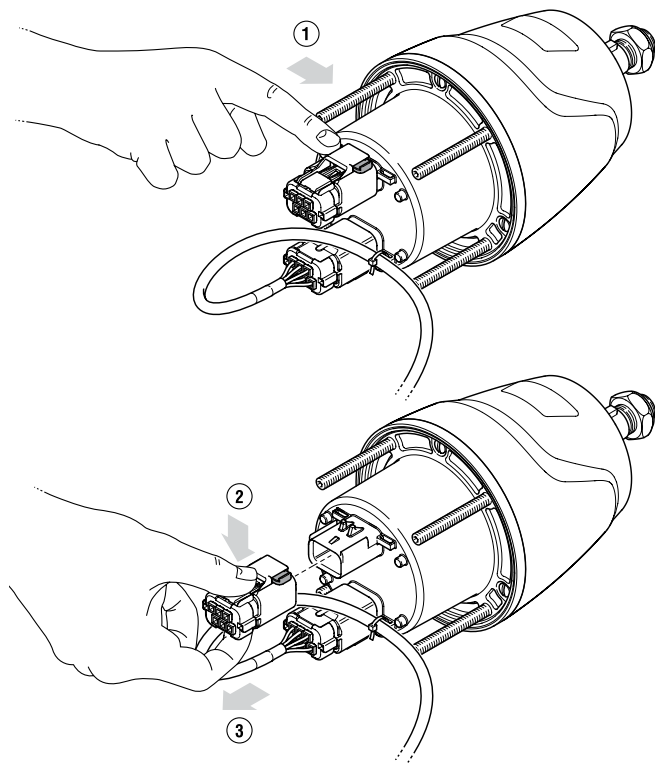

Figure 6-4.

## 6.2.2 Connecting a Second Station

Figure 6-5 shows the acceptable CAN1 connections when adding a second station. If harness lengths allow (see Section 4.3.1), connect the second helm to the second CAN1 port as shown in a). This parallel configuration makes it less likely that both helms would be lost if a wiring harness is damaged.

In some cases the control station layout will require a series connection as shown in b). This is allowable provided the total harness length does not exceed 36 feet. This configuration requires a wye harness (CM21702) in order to have enough CAN1 ports available at the main station.

If more than two helms are required then a combination of these connections will be required. In all cases the total harness length to any component may not exceed 36 feet.

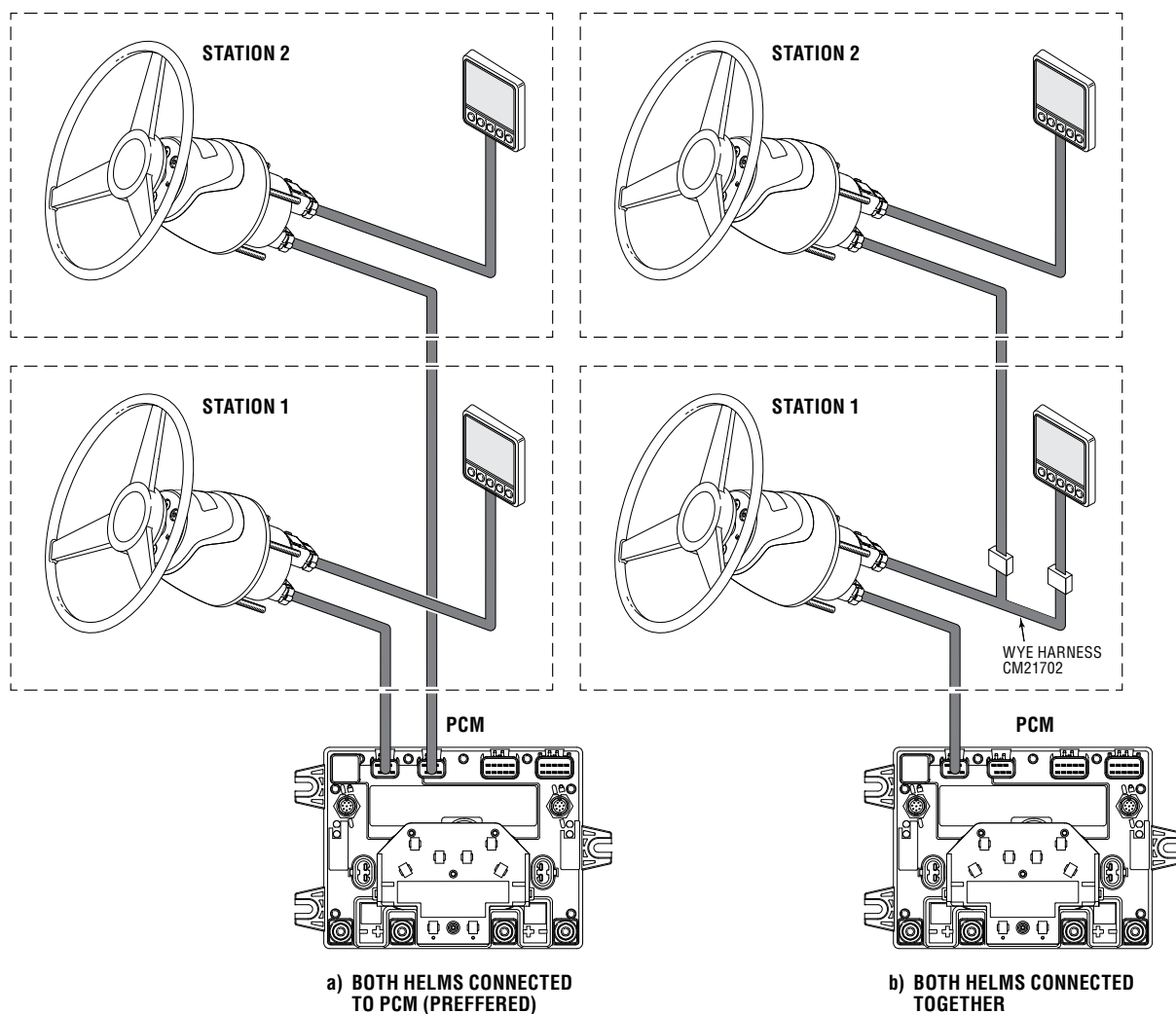

Figure 6-5. Alternate helm connections in dual-station applications.

## 6.2.3 Connecting the CANtrak

Plug harness CM21504 (CM20030 for single-engine applications) into the back of the CANtrak. The connector is keyed so that it will only go one way. Plug the rectangular CAN1 connector into the helm port and the round DeviceNet connector (multi-engine vessels only) into a CAN2 tee. Hand tighten all DeviceNet connections. Do not use tools.

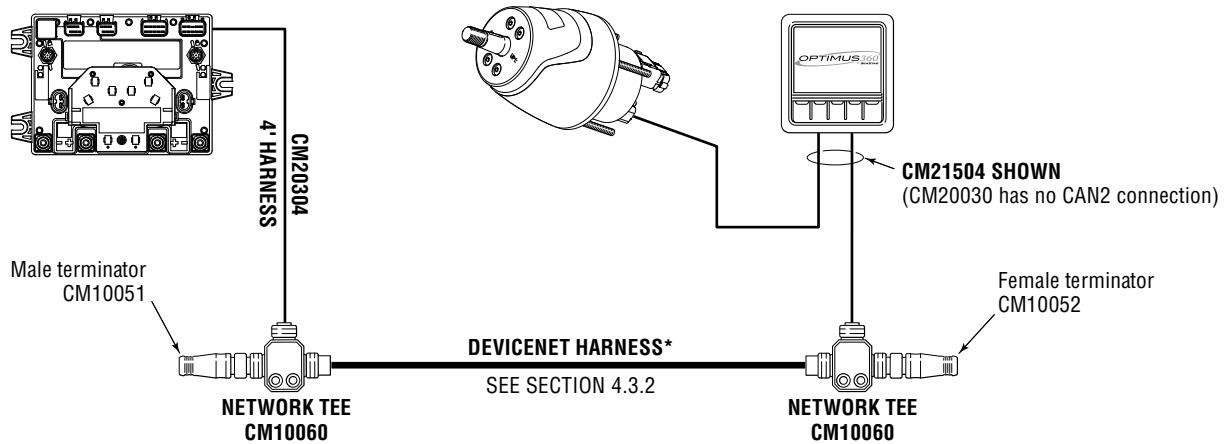

Figure 6-6. CANtrak connections. Multi-engine application shown.

### ⚠ CAUTION

All network Tees **MUST** be mounted securely using screws through both mounting holes.

### ⚠ CAUTION

Do not connect anything other than SeaStar Optimus components, or SeaStar approved autopilots, to the CAN2 network.

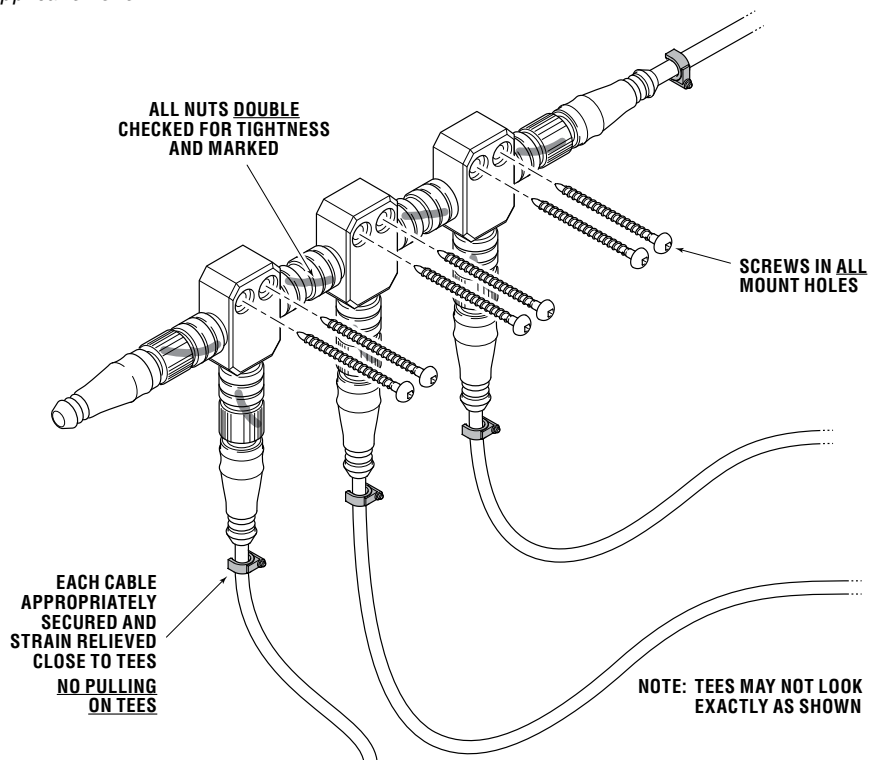

Figure 6-7.

When the installation is complete, Use a permanent marker to draw a line across all of the DeviceNet connections. If one of the connections becomes loose, it will be evident.

## 6.3 Power Wiring

### **⚠ WARNING**

**ALL ELECTRICAL CONNECTIONS AND HARNESS MUST COMPLY WITH ABYC WIRING STANDARDS, BE RATED FOR 105° C (221° F), AND COMPLIANT WITH SAEJ1128.**

### **6.3.1 PCM Wiring**

The proper wire gauge must be used. See Section 4.4.2 for proper AWG selection.

Use wire with red insulation for the positive connections and wire with black or yellow insulation for the negative connections.

1. Mount two 60 amp breakers, one for the port and one for the starboard power feed to each PCM within 7 inches from the power source. Use only circuit breakers designed for marine use, and with corrosion-resistant, stainless steel connection hardware.

ABYC Standards require the breakers be placed close to the batteries to protect the wires in case they are shorted. See the Standard for complete details about the allowable wire length and placement of the breakers as they vary depending on how the batteries are located and protected.

### **⚠ CAUTION**

**Crimped and soldered connector lugs must be used on all PCM power connections.**

### **⚠ CAUTION**

**DO NOT use Automatic Power Selectors (APS) or selector diodes of any kind on the PCM power or ignition wires. This functionality is already built into the PCM.**

### **⚠ WARNING**

**NO ADDITIONAL DEVICES OR LOADS SHOULD BE CONNECTED TO THE PCM POWER AND GROUND POSTS. THE 60 AMP FUSE COULD BE BLOWN, WHICH COULD RESULT IN LOSS OF STEERING CONTROL, PROPERTY DAMAGE, PERSONAL INJURY AND/OR DEATH.**

2. Run a wire from the negative terminal of the port battery to the negative terminal of the PCM port side. Run a separate wire from the negative terminal of the starboard battery to the negative terminal of the PCM starboard side.
3. Run the positive wires as shown in the diagram.

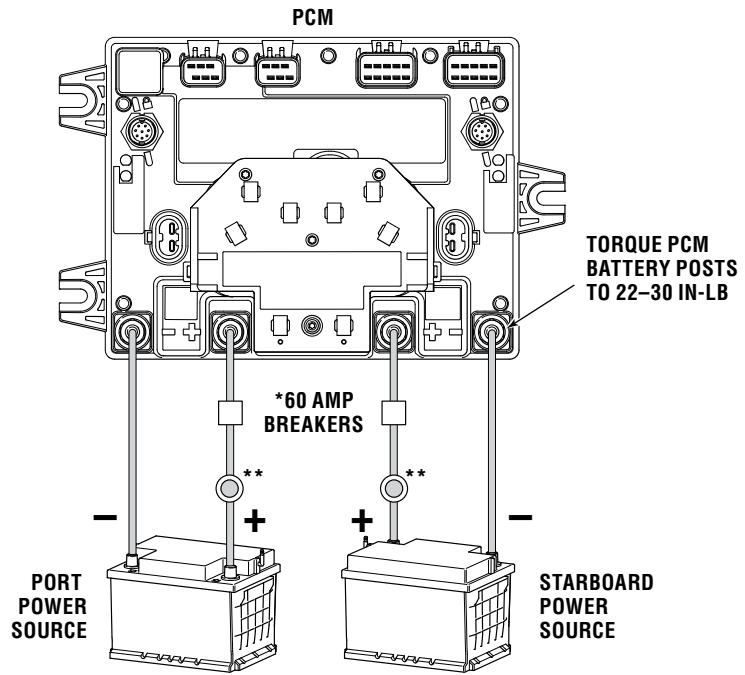

Figure 6-8.

- \*Breakers are not supplied as part of the SeaStar Solutions Kit.
- \*\* Battery Switch (PCM power may be connected directly to the battery or to the battery switch).

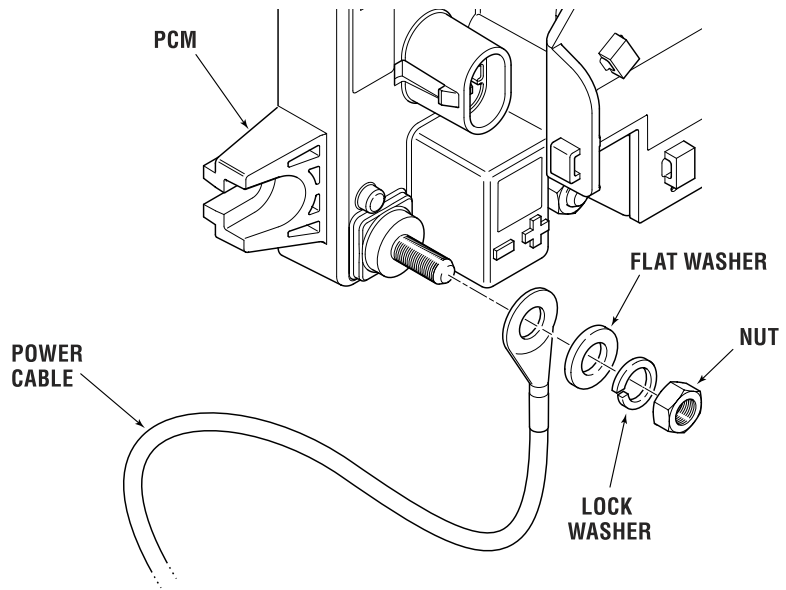

Figure 6-9.

## 6.3.2 PCM Wiring Strain Relief

- When all connections are made, strain relieve the wires as shown below. Be sure to properly strain relieve the wires at the power source as well.
- All unused ports must have sealing caps.

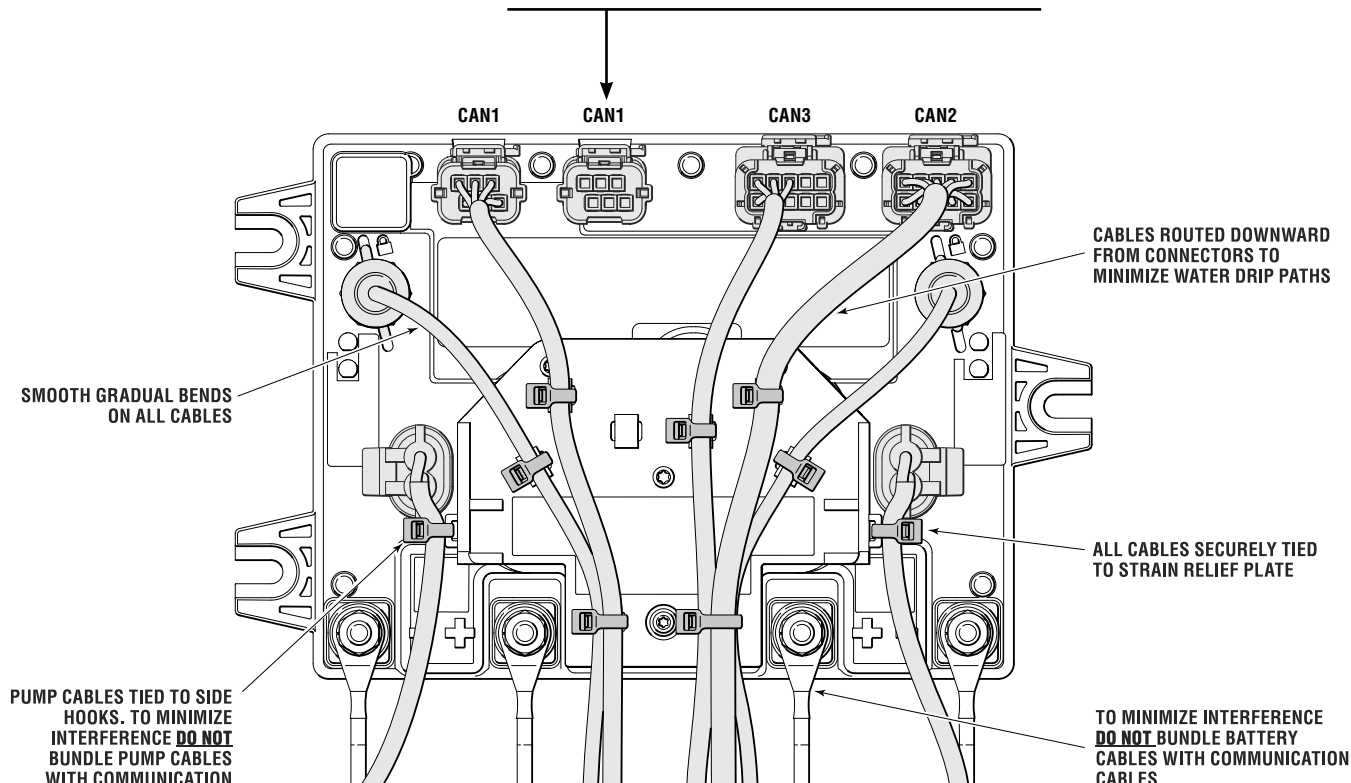

Figure 6-10.

### **⚠ WARNING**

**FAILURE TO SECURE HARNESS, AS SHOWN, MAY RESULT IN HARNESS WEAR, CAUSING LOSS OF STEERING CONTROL, PROPERTY DAMAGE, PERSONAL INJURY AND/OR DEATH.**

### **⚠ WARNING**

**ALL UNUSED CONNECTORS REQUIRE SEALING PLUGS. THEY WILL LIKELY BE REQUIRED ON PCM AND THE HELM.**

## 6.4 Ignition Sensing

The CM20304 harness connects through the CAN2 port on the PCM. It has two violet ignition sensing wires that must be connected to an ignition source (has 12V when ignition is on). See section 6.4.1 for important ignition splicing instructions.

### **⚠ DANGER**

**THE INTEGRITY OF THE IGNITION SENSING CIRCUIT IS CRITICAL TO THE SAFE OPERATION OF THE STEERING SYSTEM. ALWAYS CONNECT BOTH SENSING LEADS AND ENSURE THAT WIRING AND SPLICES ARE PROPERLY STRAIN-RELIEVED AND PROTECTED FROM DAMAGE, WATER, OR OTHER HAZARDS.**

Twin-engine applications: Connect one sensing wire to the starboard ignition and the other to the port ignition.

Triple- and quad-engine applications: The ignition sensing wires must be connected in such a way that an ignition-on signal is received when any of the engine ignition switches are on. Some vessels may already be wired to deliver such an ignition signal, but you may require one or two Dual Ignition Kits (HA1201) to appropriately combine the ignition sources into a pair of signals for connection to the sensing wires.

Single engine applications: Connect one sensing wire to the engine ignition. Connect the second sensing wire to either a separately switched 12V source (preferred) or the same source. NEVER leave the second sensing wire unconnected. These connection options are illustrated in figure 2-3.

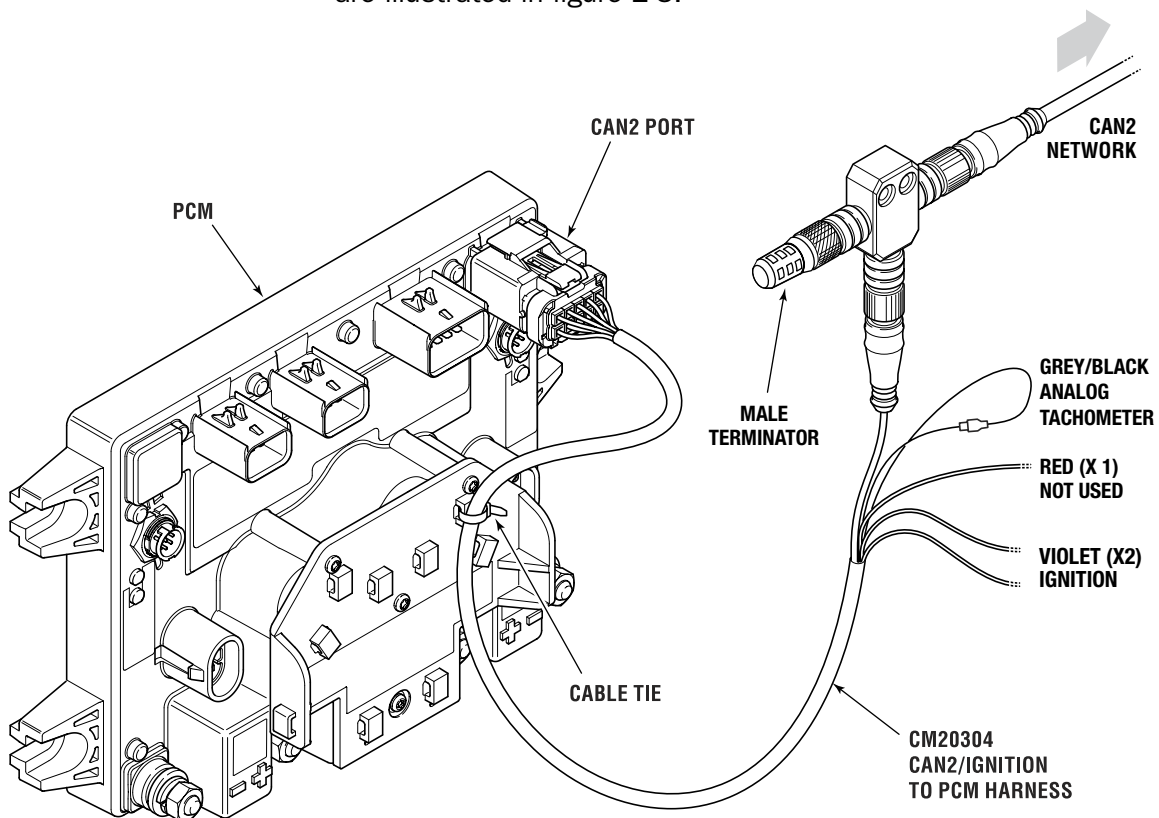

Figure 6-11.



## 6.4.1 Ignition Splicing

The integrity of the ignition connection is critical to the safe operation of the Optimus EPS steering system. Please note the following:

- Whenever possible, make your splice connections in dry areas of the vessel. If you must splice in a potentially wet area, always secure the wires in a way that keeps the splice out of pooling water.
- Use sealed, heat-shrink butt splices, such as Molex Perma-Seal, or a soldered connection with heat-shrink tubing. Always follow the manufacturer's installation instructions.
- Secure the wiring on both sides of the splice so that there is no strain on the splice connection.
- Choose a route for the wires that minimizes exposure to water, high temperatures, and mechanical damage.

On most vessels you will have one of two options for an ignition source: a single ignition source wire, or you will have to splice into an existing ignition wire.

### Option 1 – single ignition source

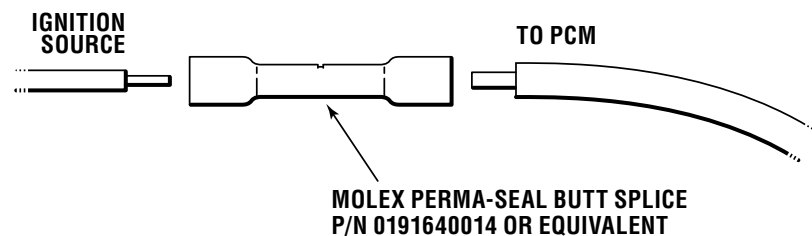

Figure 6-12

### Option 2 – splice into an existing engine ignition wire

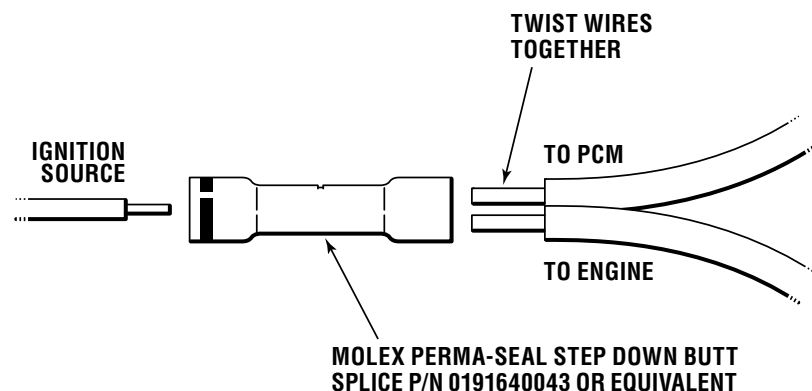

Figure 6-13.

## 6.5 Engine RPM Source

### 6.5.1 NMEA 2000 CAN Bus

There are two options for getting your engine speed source from an NMEA 2000 network.

Option 1 – Use existing bus: If an RPM signal is present on the NMEA 2000 bus you can connect the optional NMEA 2000 harness CM20503 to an available DeviceNet tee on the bus. If no tee is available, you will need to add one (CM10060). You may also require an extension harness to extend CM20503 to reach the tee.

Option 2 – Create new bus: You can create a basic NMEA2000 bus using kit HA5492. In addition to the kit you will need a gateway device that connects between the engine bus and the NMEA2000 bus, supplied by the engine manufacturer.

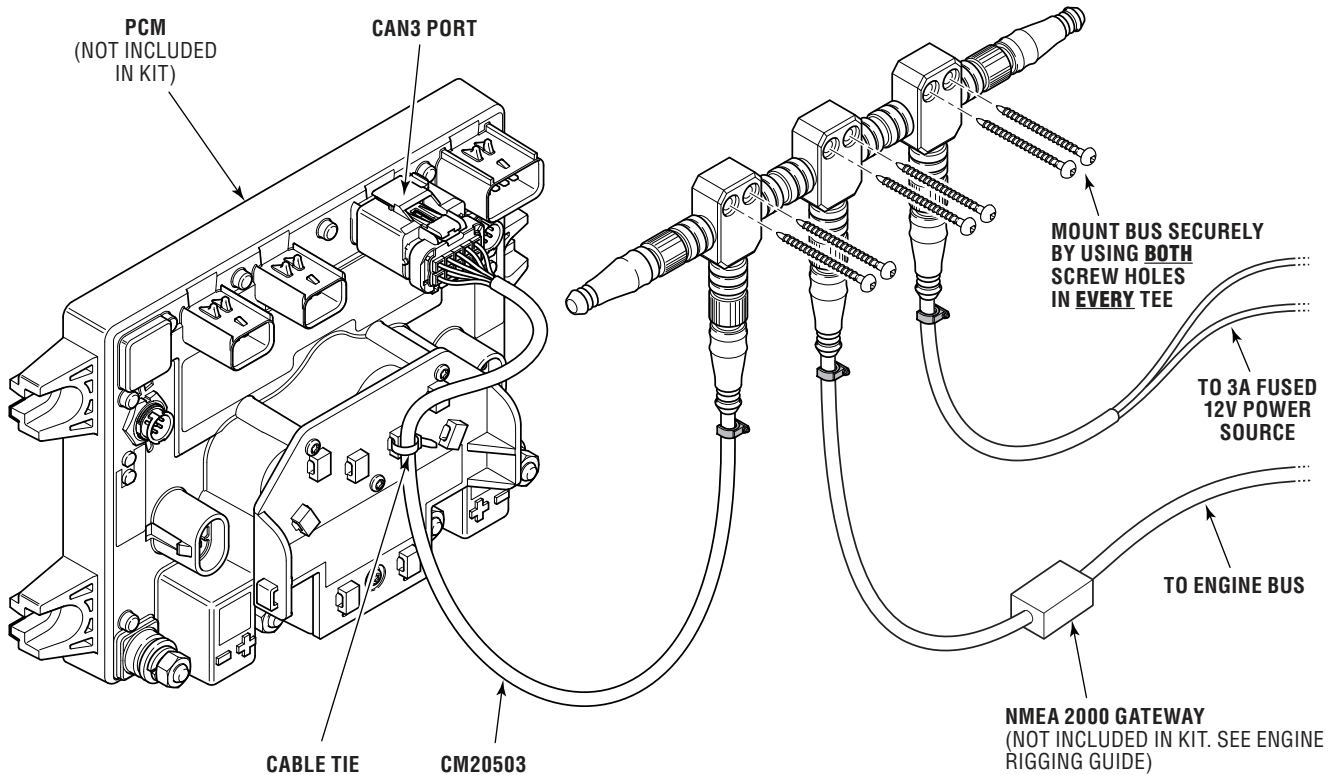

Figure 6-14. Creating an NMEA 2000 network with kit HA5492.

#### NOTICE

When using NMEA 2000 CAN Bus for engine RPMs ensure that the black and gray analog tachometer inputs from the CM20304 CAN2 Harness are connected together

## 6.5.2 Analog Tachometer

---

If you are using analog tachometers as your engine speed source, you will need to connect the gray and black tachometer leads on harness CM20304 (see figure 6-11). Connect the gray wire to the port engine analog tach input, and the black (with gray stripe) wire to the starboard analog tach input. The analog tachometer connection is not recommended for triple or quad engine applications.

The leads are fitted with Molex Perma-Seal bullet connectors. The male connector is Molex P/N 191640040 and the female connector is 191640054. Crimp and seal the mating connectors (not supplied by SeaStar) onto your tachometer leads, per the manufacturer's instructions, and push together to connect.

If you are getting your input source from an NMEA 2000 network (section 6.5.1) then you need to leave the gray and black wires connected to each other as shown in figure 6-11.

## 6.6 Autopilot Connection (Optional)

---

Autopilots certified by SeaStar as compliant with the EPS system will simply connect to an available CAN2 network tee. The connection harness is supplied by the autopilot manufacturer. Refer to the manufacturer's instructions for additional information.

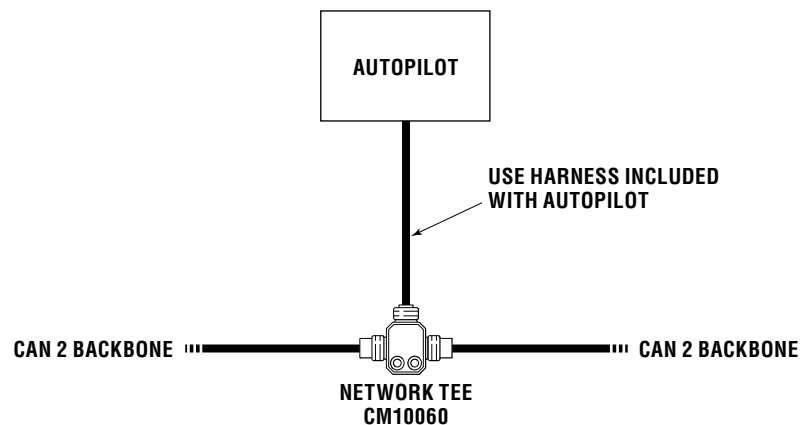

Figure 6-15. Autopilot connection to CAN 2 network.

## 6.7 Buzzer Kit (Optional)

Dual station boats do not require a CANtrak display at the second station. However, you must install a buzzer kit to notify the operator that the steering system has a fault and needs attention.

Locate the buzzer under the second station dash, near the helm. A warning label is included in the buzzer kit and **MUST** be applied to the dash in a visible location near the helm.

Connect the positive (yellow) and negative (pink) leads of the buzzer to the positive (yellow) and negative (pink) flying leads on the CANtrak harness at the main station.

Secure the wires adjacent to the splice for strain relief.

### Crimp connections as follows:

- Strip the wires 7.6 mm (.3") from the end and insert into the barrel of the butt splices provided (Molex 0191640043) observing the correct orientation shown below:

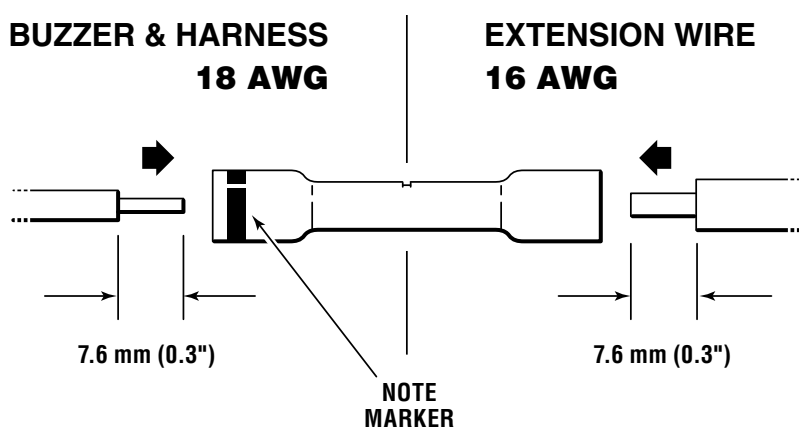

Figure 6-16.

- Making sure the wire end is properly seated, make the crimp connection using the recommended tool (Molex 0640014500, not included).
- Apply heat directly to the splice, working from the center out to the edges, using a hot air gun or other heat source, until the tubing shrinks and the adhesive flows.
- Allow to cool before inspecting splice and checking the integrity.

### ⚠ CAUTION

**Reversing the polarity of the buzzer may result in damage to the CANtrak harness and/or CANtrak display. 16AWG wire has been included in the kit to power the buzzer and comply with ABYC E-11. Refer to the ABYC E-11 for required gauge if longer wire runs are required.**

# 7.0 SETUP, PURGING, AND CALIBRATION

At this point you should have all your system components installed, network harnesses connected, and your power source connected. You will set up, purge, and calibrate the system using the color CANtrak display. Refer to Appendix D for display navigation and instructions for accessing dealer menus.

## 7.1 Initial System Setup

### NOTICE

*It is important to perform these system setup steps in the order listed on the display.*

The system setup is performed easily with the color CANtrak display. It is designed to walk you through the following tasks:

- Configure the system type
- Choose the number of helms and displays in your system
- Select device locations
- Choose your RPM source and tachometer PPR (if applicable)

**You will need access to the CANtrak Dealer Menu for all setup tasks.** See Appendix D for instructions.

#### Procedure:

1. On the display, navigate to **Dealer Menu > Initial Setup > System** to access the System Setup menu.

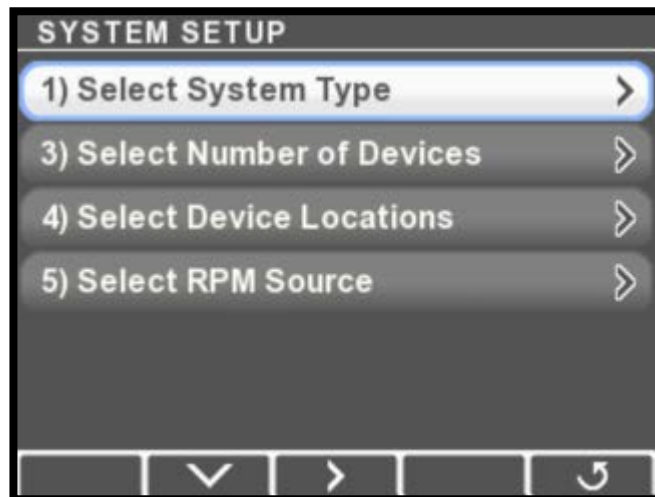

Figure 7-1.

2. Press **>** to enter the System Type menu.

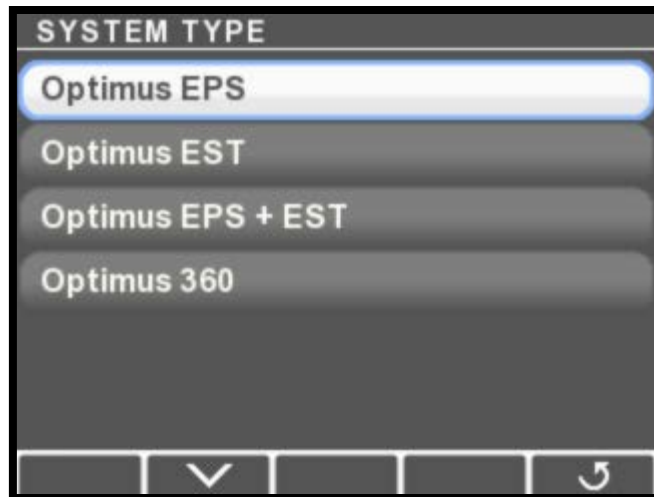

Figure 7-2.

3. Select **Optimus EPS** then press **Save** or **↵** to return to the System Setup menu. When you set the system type the CANtrak automatically configures the menus to show only items that relate to your system.
4. Choose **Select Number of Devices** and press **>**.

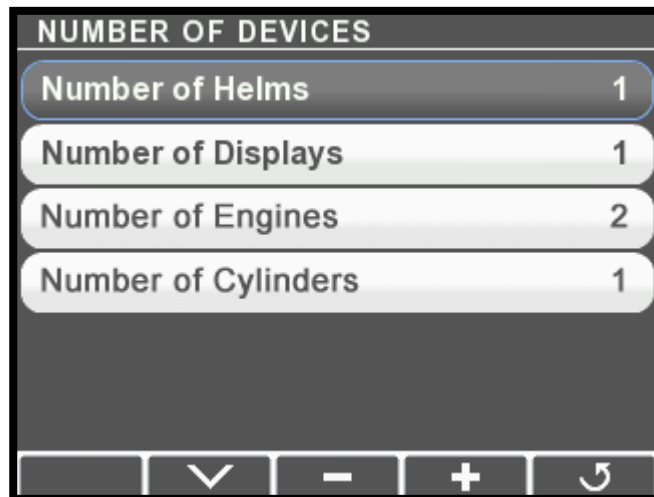

Figure 7-3.

5. Use the **+** and **-** buttons to change the number of devices to match your system. Press **Save** or **↵** when finished to return to the System Setup menu.

6. Multiple helm stations only: choose **Select Device Locations** from the System Setup menu and press **>**. The display will list the installed components along with their serial numbers. Check the serial numbers and use the **+** and **-** buttons to toggle the components between Main and Second station. Press **Save** to return to the System Setup menu.
7. Choose **Select RPM Source** from the System Setup menu and press **>**.

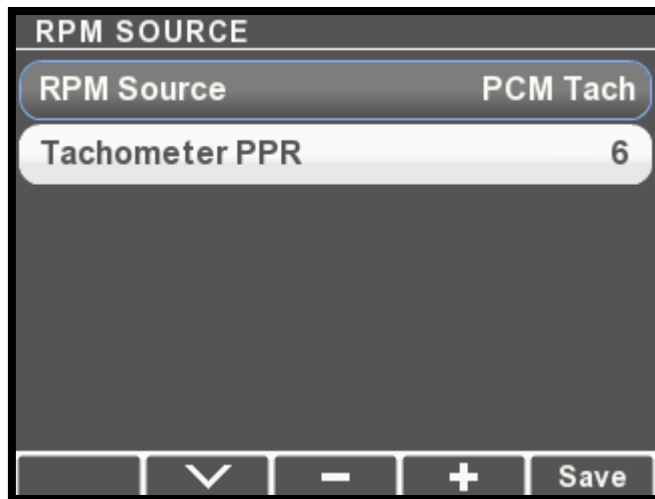

Figure 7-4.

**For Datalink users:** the number of devices and RPM source parameters are found on the Configuration tab of the Color Display interface. Helm instance is found on the Configuration tab of the Helm interface.

8. Press **+** and **-** to scroll through the available options: PCM Tach, NMEA2000, i7700 Tach, and Electronic Engines. Press **Save** when you've selected your source.
9. If you chose PCM Tach as the source, you may need to adjust the Tachometer PPR parameter. Select **Tachometer PPR** and use the **+** and **-** buttons to adjust. Press **Save** to return.
10. Update your system software. See Appendix E.

You are now ready purge your steering system. Proceed to section 7.2.

## 7.2 Purging the Steering System

To purge the EPS system you will require the following supplies and equipment:

- Optimus EPS Steering Fluid, HA5482. A typical new installation will require about one US gallon (3.8l) of fluid, supplied with your core component kit.
- Purge hose kit HA5486 (15ft [4.5m]) or HA5487 (30ft [9m]).
- A 1/2" (13 mm) and 5/8" (16 mm) open end wrench.

### 7.2.1 Preparation

#### **CAUTION**

The system is bled one engine at a time. Since the engine being bled will move over its full steering range, it may hit the inactive (not being bled) engine. Move the engine not being bled as far outboard as possible to assure the engines do not collide. If the inactive engine will not move manually open the service valve for that engine.

On the engine being purged, remove the two black caps on the SmartCylinder bleed fittings, and the black cap on the corresponding power steering pump bleed fitting. Connect the purge hose as shown. Open all three bleeders 1-1/2 to 2 turns.

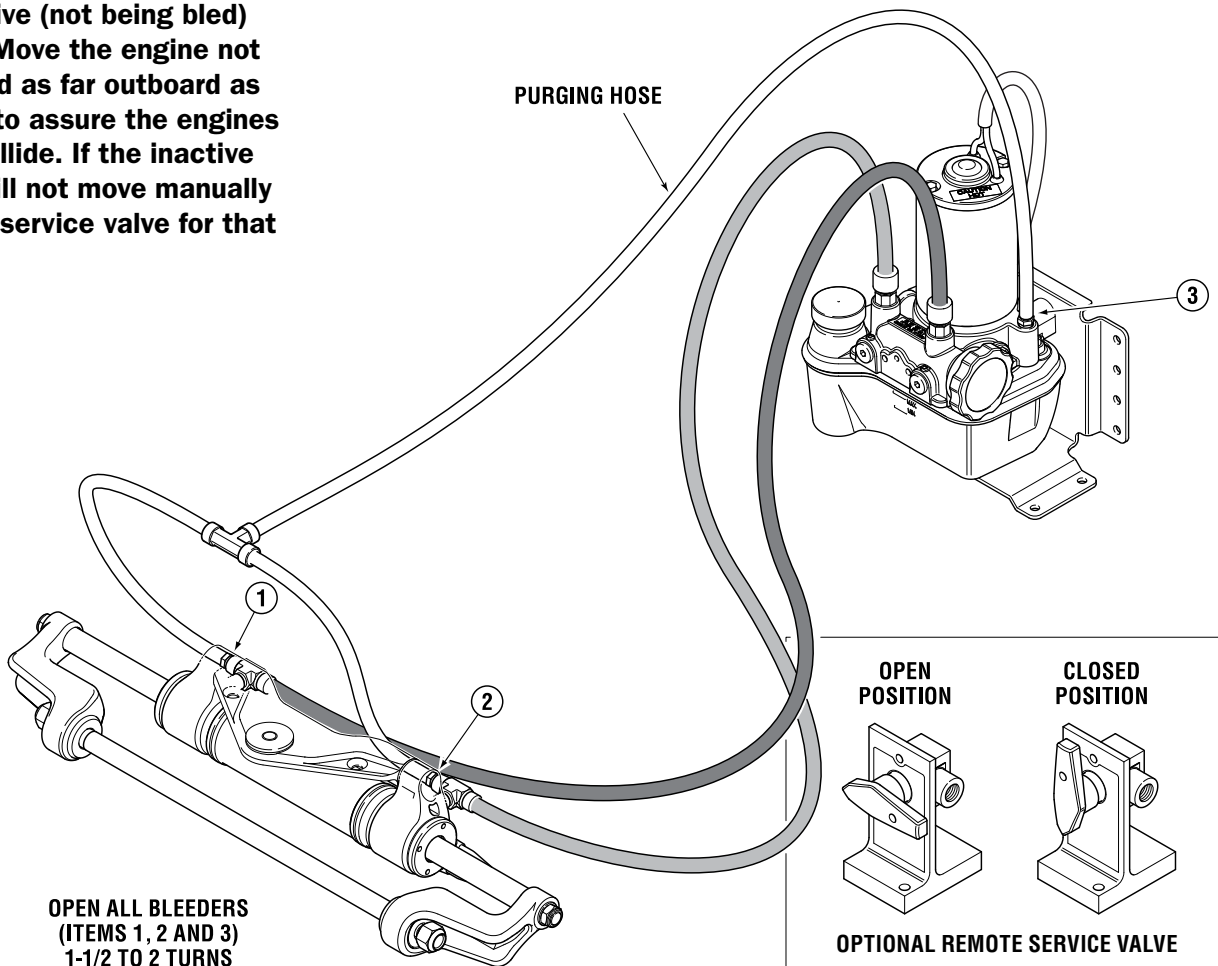

Figure 7-5.



## 7.2.2 The Purging Process

### NOTICE

**Note: For Service Valve Operation, see page 7-4.**

#### **Single Engine Applications:**

Disregard references to additional engines/cylinders. The cylinder is treated as the Port cylinder on the CANtrak display and in Datalink.

If the engine being purged requires the cylinder steering angle to be limited – such as to avoid interference – the cylinder must be purged, calibrated, and the stroke setting changed with the cylinder support brackets removed. See Section 5.4 for brackets. See Section 7.2 for limiting cylinder travel.

1. Move the engine(s) not being bled as far outboard as possible. This may require opening the service valve for that engine.
2. Center the engine being bled and close the service valve for that engine.
3. Fill the reservoir on the Hydraulic pump being bled to the MAX level. DO NOT OVERFILL as air coming back during purge may cause the fluid to overflow.

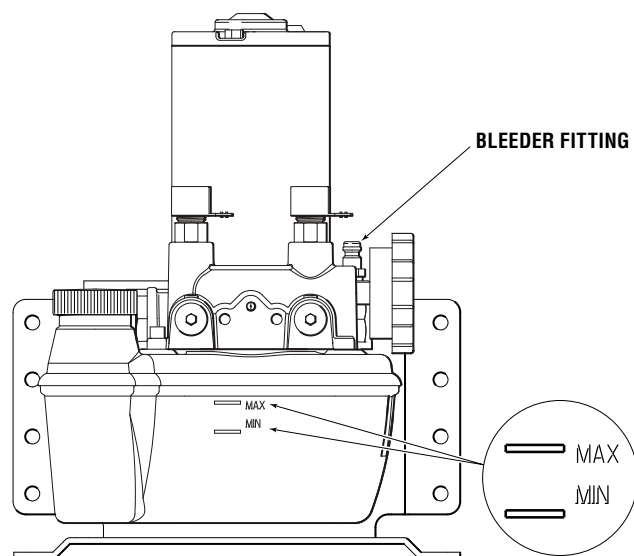

Figure 7-6.

4. Double check that the purge hose is connected to the CORRECT pump and cylinder for the engine being bled. Failure to do so may damage the bleed hose.
5. Verify that all three bleed fittings are open 1 ½ to 2 turns.
6. Power on the Optimus system.

### ⚠ CAUTION

**DO NOT turn the helm at this time or the hydraulic pump will run. Should this accidentally occur power off the system for 3 seconds then power back on. This will stop the pump.**

**For Datalink users:** the purge commands are found on the Configuration tab of the PCM interface.

7. On the CANtrak display, navigate to **Dealer Menu > Initial Setup > Steering > Purge Cylinders** to access the Purge Cylinders menu.

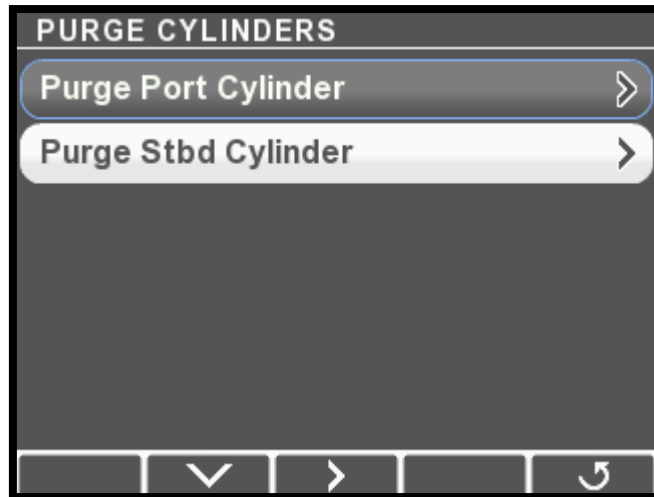

Figure 7-7.

## NOTICE

*If the helm has been steered since the ignition was turned on the system will not enter purge mode. You will need to cycle power again.*

8. Select the cylinder you wish to purge and press > to enter Purge Mode.

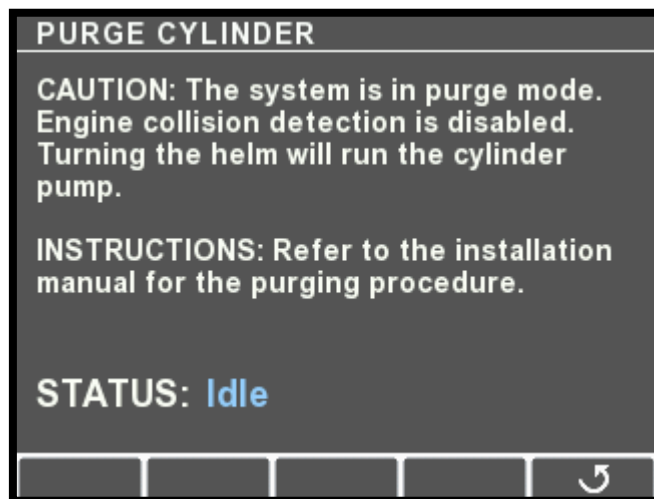

Figure 7-8.

## NOTICE

*When purging you will be required to turn the helm AND maintain fluid level in the pump reservoir. The pump can empty the reservoir quickly while purging. When the fluid level in the reservoir drops to the MIN mark, stop turning the steering wheel and refill the reservoir to the MAX mark. DO NOT ALLOW THE FLUID LEVEL TO GO BELOW THE MIN MARK.*

- 9.** Turn the helm one direction to start the purging process. The pump will run as the wheel is being turned. Continue turning the wheel until the cylinder reaches the end of travel. Verify the pump oil level frequently.
- 10.** Turn the wheel in the opposite direction until the cylinder reaches the end of travel. Verify the pump oil level frequently.
- 11.** Repeat steps 9 & 10 until no more air bubbles appear in the purge hose. Verify pump oil level frequently
- 12.** Close both cylinder bleeders. DO NOT close the pump bleeder yet.
- 13.** Open the service valve for the engine being purged and move the engine by hand so that the cylinder moves about 3 inches.
- 14.** Close the service valve.
- 15.** Re-open the cylinder bleeders 1 ½ to 2 turns.
- 16.** Repeat steps 9 & 10 until no more air bubbles appear in the purge hose. Verify pump oil level frequently.
- 17.** Close all three bleed fittings, remove the purge hose and replace the bleeder protective caps.
- 18.** Press **J** to return to the Purge Cylinders menu. If this is a single engine application skip to step 21.
- 19.** Move the purge hose to the next cylinder and pump to be purged.
- 20.** Repeat steps 7 to 18 for the other cylinder.
- 21.** If you need to calibrate the SmartCylinders, proceed to section 7.3 now. Otherwise, press **J** repeatedly to exit. You will be prompted to perform a key cycle in order to exit the steering setup.

**TIP:** When purging is complete the cylinder should have 3/8" or less of movement when physically trying to shake the engine back and forth.

## 7.3 Calibrating the SmartCylinders

### ⚠ WARNING

**DURING THE CALIBRATION PROCEDURE THE ENGINES WILL MOVE THE FULL TRAVEL OF THE STEERING RANGE. CONFIRM THERE ARE NO OBSTRUCTIONS IN THE PATH OF THE ENGINES. IF THERE IS AN OBSTRUCTION REQUIRING STROKE REDUCTION, THE CYLINDER MUST FIRST BE CALIBRATED WITH THE SUPPORT BRACKETS REMOVED.**

### ⚠ CAUTION

**The Optimus EPS system must be fully purged of air before calibration is attempted. Any air in the system will prohibit calibration and will cause the system to exhibit faults.**

#### **Single Engine Applications:**

*Disregard references to additional engines/cylinders. The cylinder is treated as the Port cylinder on the CANtrak display and in Datalink.*

1. Open the starboard service valve, move the starboard engine as far outboard as possible, then close the service valve again. This will prevent collision when the port engine moves during calibration.
2. On the CANtrak display, navigate to **Dealer Menu > Initial Setup > Steering > Calibrate Cylinders** to access the Calibrate Cylinders menu.

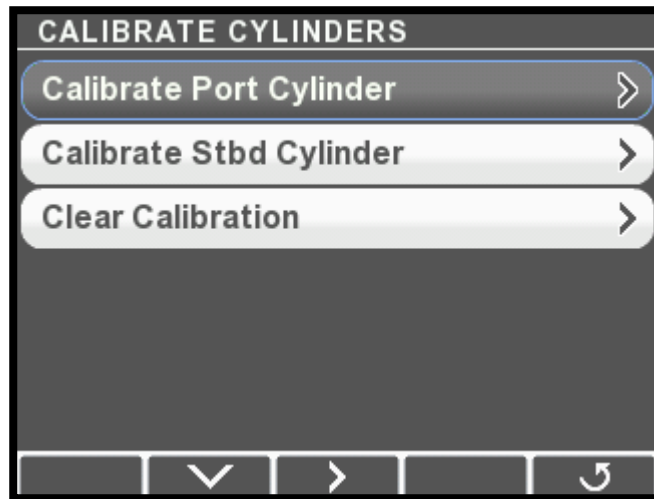

Figure 7-9.

3. Select **Calibrate Port Cylinder** and press > to enter Calibration Mode.

## NOTICE

The system uses pump current to detect hardstop, and may falsely detect a hardstop if the wheel is turned too quickly. Be sure to turn the wheel slowly and smoothly.

If the calibration shows complete and you aren't certain that you hit both hardstops, repeat the procedure.

**For Datalink users:** the calibration commands and RFU feedback are found on the Configuration tab of the PCM interface.

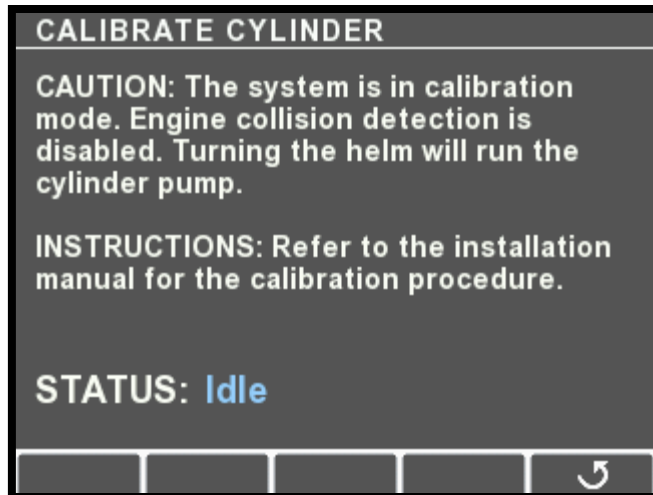



Figure 7-10.

4. Turn the helm to starboard until the status indicator reports hardstop is reached. Immediately turn the helm to port until hardstop is reported. When finished, the port engine should be turned all the way outboard. If not, turn it to the port hardstop now.
5. When calibration is complete, you will be returned to the Purge Cylinders menu. If this is a single engine application skip to step 7.
6. Repeat the calibration procedure for the starboard cylinder.
7. When calibration is complete, press  repeatedly to exit. You will be prompted to perform a key cycle in order to save the calibration and exit the steering setup.
8. Power up the system and turn the helm. The engines should align automatically, and the steering should operate normally. If the display reports a calibration error you will need to re-calibrate the indicated cylinder.

### 7.3.1 Restricting SmartCylinder Travel

Some engine mountings and transom designs require that you limit the SmartCylinder travel in order to prevent interference between engine cowlings or other parts of the vessel. The cylinder travel can be restricted by adjusting the maximum steering angle parameter.

To determine if you need to restrict the maximum steering angle:

- Slowly turn the helm from lock-to-lock while a helper visually inspects the engine cowling(s) and transom area for any interference.
- Check with the engine(s) tilted up and down.

If you find interference towards the end of the cylinder travel, you will need to adjust the maximum steering angle. Follow the instructions below.

**⚠ WARNING**

**THE OPTIMUS EPS SYSTEM MUST BE FULLY PURGED OF AIR AND THE SMARTCYLINDER MUST BE CALIBRATED BEFORE THE STEERING ANGLE IS ADJUSTED.**

**⚠ WARNING**

**CHANGING PCM PARAMETERS MAY CAUSE THE ENGINE TO MOVE AUTOMATICALLY AS SOON AS THE PARAMETERS ARE ENTERED.**

1. On the display, navigate to **Dealer Menu > Initial Setup > Steering > Set Cylinder Stroke Limits** to access the adjustment menu. There are parameters for Max Steering Angle and Max Joystick Angle. Unless you are setting up an Optimus 360 system you can ignore the Max Joystick Angle parameter.



Figure 7-11.

**For Datalink users:** the Max Steering Angle parameter is found on the Configuration tab of the PCM interface.

2. Select **Max Steering Angle** and use the **-** button to decrease the Max Steering Angle. We recommend one degree to start. Each press will reduce the steering angle by 0.1 degrees.
4. Press **Save**.
5. Check again for interference and adjust the Max Steering Angle as necessary. For the best steering performance, restrict the travel as little as possible.

## 7.4 Steering Settings

### NOTICE

*We recommend that you leave these settings at their default value and revisit this section during your sea trial.*

The Optimus EPS system provides a number of adjustable steering settings, described in section 7.4.2. You can use these settings to fine tune the vessel's steering performance and helm feel.

A key feature of Optimus EPS is the adjustable steering effort and number of turns. Both of these parameters are set for low and high speed operation, and the system smoothly transitions them as boat speed changes. Figure 7-12 shows how these parameters change with speed.

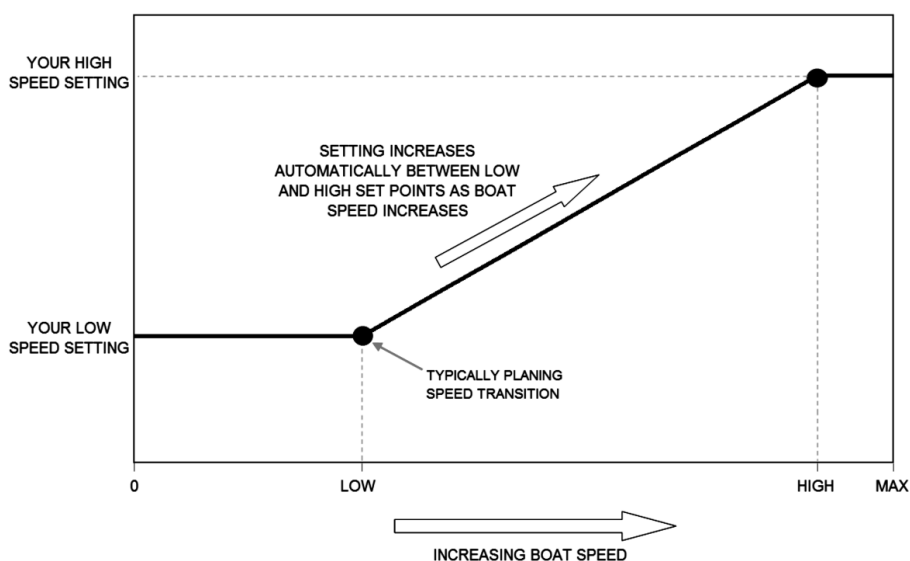

Figure 7-12.

## 7.4.1 Adjustment

Adjust the settings with the color CANtrak display. Navigate to **Dealer Menu > Settings > Steering > Steering Settings**. Figure 7-13 shows the Steering Settings menu display. You will need to scroll through to see all of the parameters.

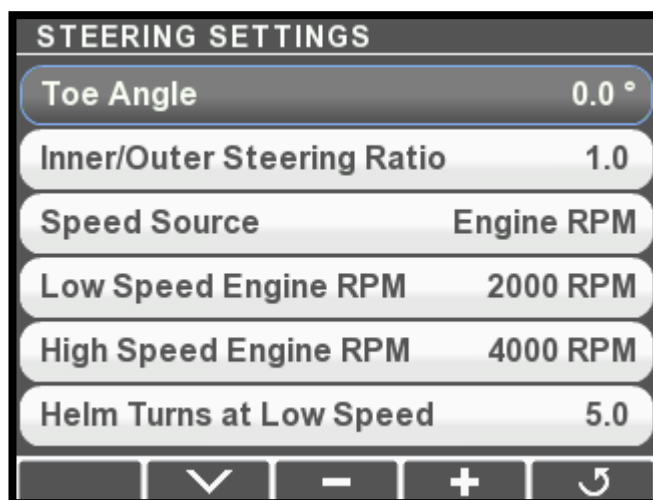

Figure 7-13.

Select the parameter to adjust, then use the **+** and **-** buttons to change the value. Changes will not take effect until you exit the Steering Settings menu and confirm that you want to save the changes.

### **⚠ CAUTION**

**Make adjustments in small increments and then trial them. Large changes may introduce unexpected steering behavior.**



## 7.4.2 Available Settings

*For Datalink users: these parameters are available in the Configuration tab of the PCM interface.*

PARAMETER NAME	DESCRIPTION	RANGE	DEFAULT VALUE
Toe Angle	Sets the static toe angle of the engines. A positive value will toe the engines out (gear cases farther apart at front edge).	-5 to 5	0
Inner/Outer Steering Ratio	Similar to Ackerman compensation on road vehicles, this parameter can make the inner engine turn more than the outer engine in a turn. The higher the value, the less the outer engine will turn. e.g. A value of 2.0 will deliver 15 degrees of steering at the outer engine when the inner engine is steered at 30 degrees.	1 to 3	1.0
Speed Source	Sets how the boat speed is determined. Except in rare cases, you should leave this as the default value.		Engine RPM
Low Speed Engine RPM	Sets the engine RPM that marks the upper boundary of low speed. Typically the RPM at which the boat begins to plane. See figure 7-12	0 to 10000	2000
High Speed Engine RPM	Sets the engine RPM that marks the lower boundary of high speed. Typically close to maximum RPM. See figure 7-12	0 to 10000	4000
Helm Turns at Low Speed	Sets the number of turns when the vessel is running at low speed.	3.5 to 8.5	5
Helm Turns at High Speed	Sets the number of turns when the vessel is running at high speed.	3.5 to 8.5	5
Helm Effort at Low Speed	Sets the helm effort when the vessel is running at low speed. The value is a percentage of maximum effort (steering locked).	1 to 100	40
Helm Effort at High Speed	Sets the helm effort when the vessel is running at high speed.	1 to 100	60
Helm Effort in Auto-Pilot	Sets the helm effort when the vessel is in autopilot. Set it high enough to prevent accidental movement of the helm.	1 to 100	90

Table 7-1. Steering Settings

### 7.4.3 User Permissions

The ability to adjust steering effort and helm turns is limited to those with access to the Dealer Menu, but they can be made available to the user.

On the display, navigate to **Dealer Menu > Settings > Display**. Press **+** to toggle the setting. You will be prompted to save the setting on exit.

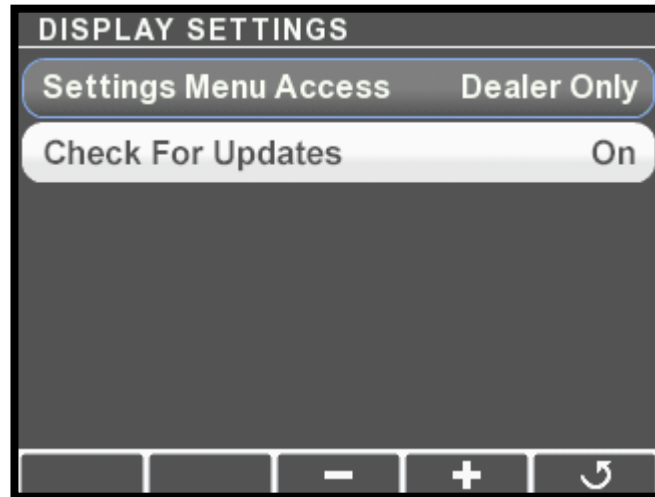

**For Datalink users:** this parameter is available in the Configuration tab of the Color Display interface.

Figure 7-14.

# 8.0 COMMISSIONING

---

At this point you have a fully functional steering system. Before handing the vessel over to the customer there are a few commissioning tasks to perform. They are described in this section.

- Check the cylinder installation for interference
- Perform pre-trip checks
- Sea trial the vessel
- Complete the warranty checklist

## 8.1 Installation Checks

---

To verify correct installation of the Optimus SmartCylinder, perform the following installation checks before sea trial and after each boat servicing. You will need someone to assist you.

### WARNING

**FAILURE TO PERFORM THESE CHECKS MAY RESULT IN DAMAGE TO THE SMARTCYLINDER SENSOR AND AFFECT THE SAFE OPERATION OF THE BOAT'S STEERING.**

**1. Interference Checks** – Confirm that there is no interference between the steering cylinder(s), splashwell, outboard engine(s), or any combination of these parts, by performing the steps below. For each step also check that the hoses and cables are moving freely with no rubbing or binding (see figure 8-1 and figure 8-2). Be sure to steer slowly while performing these checks.

a) With the engine(s) fully tilted DOWN, turn the steering wheel from hard over to hard over and confirm that no interference occurs.

b) With the engine(s) fully tilted UP, turn the steering wheel from hard over to hard over and confirm that no interference occurs.

For multi-engine vessels only:

c) Trim the port engine(s) fully DOWN and the starboard engine(s) fully UP. Turn the steering wheel from hard over to hard over and confirm that no interference occurs.

d) Trim the starboard engine(s) fully DOWN and the port engine(s) fully UP. Turn the steering wheel from hard over to hard over and confirm that no interference occurs.

**2. Sensor cable** – Confirm that the SmartCylinder Sensor Cable is tied securely to the hoses with gradual bends as shown figure 8-2.

**⚠ WARNING**

**IF ANY ISSUES ARE FOUND DURING THE INSTALLATION CHECKS, IMMEDIATELY RETURN THE BOAT TO THE SERVICE DEALER FOR THOSE ISSUES TO BE REMEDIED.**

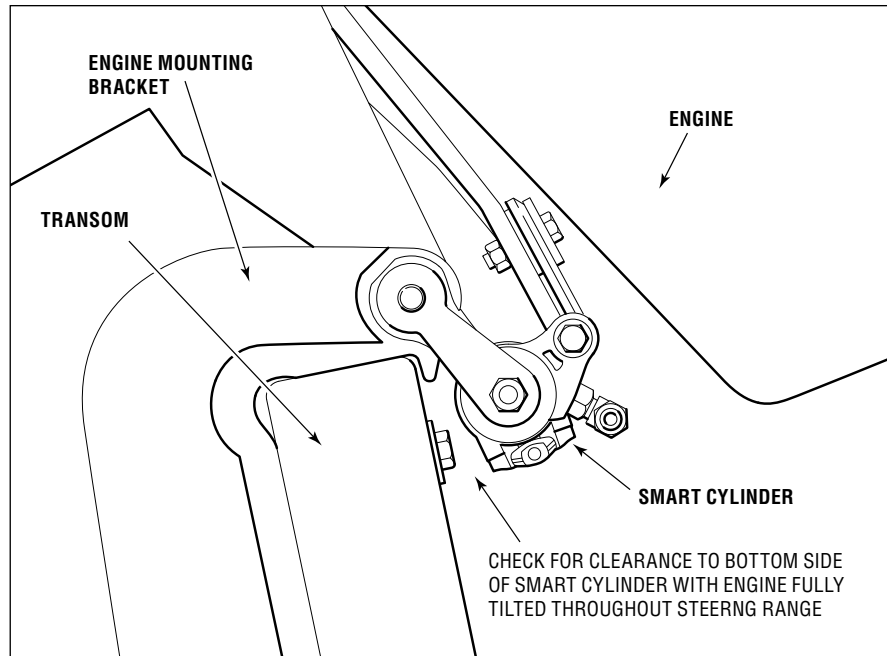

Figure 8-1. Engine side view when tilted.

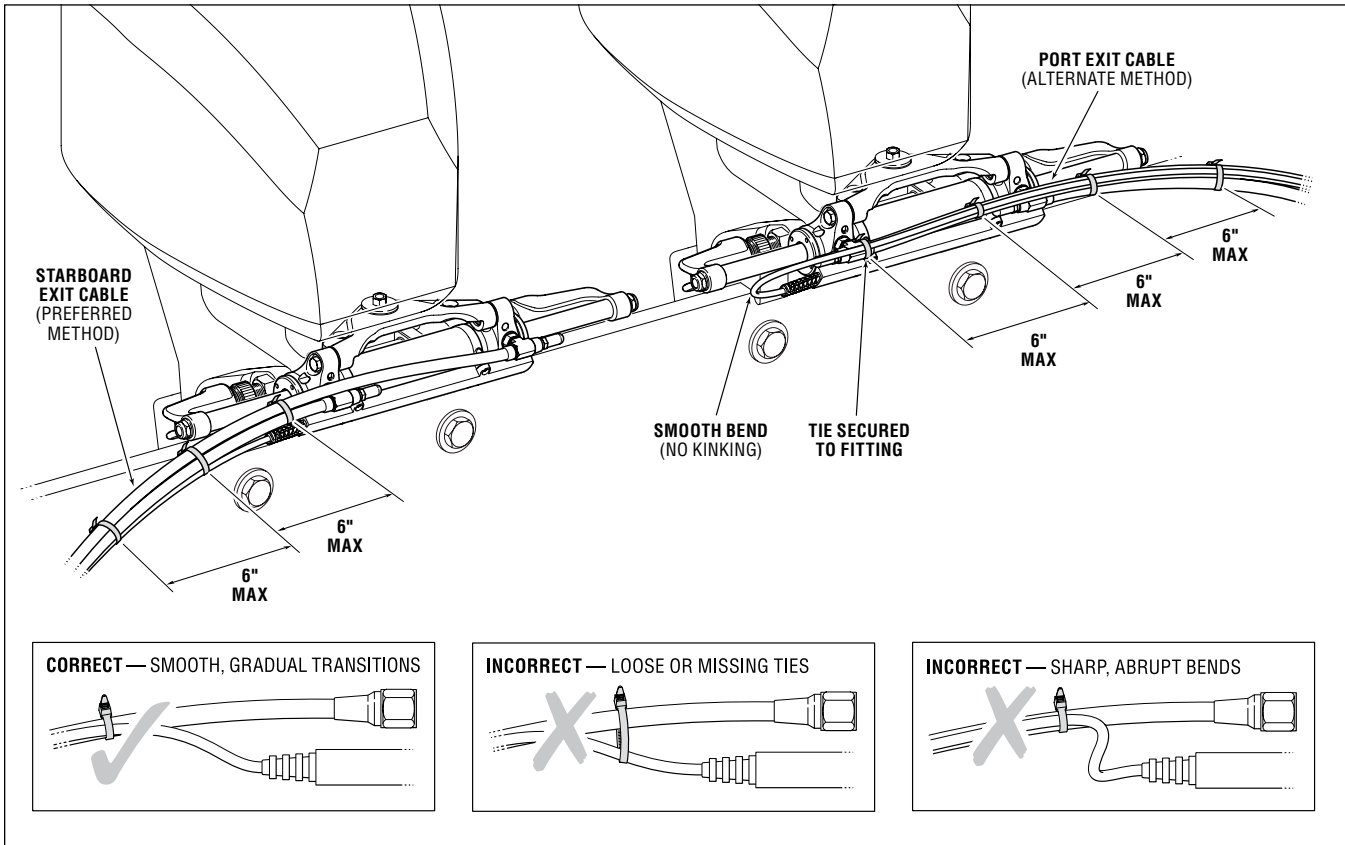

Figure 8-2. Sensor cable and hose routing checks.

## 8.2 Pre-trip Checks

### ⚠ WARNING

**FAILURE TO ADHERE TO THESE WARNINGS MAY RESULT IN LOSS OF BOAT CONTROL, LEADING TO POSSIBLE EJECTION FROM VESSEL; CAUSING PROPERTY DAMAGE, PERSONAL INJURY AND/OR DEATH.**

#### 1. Check steering fluid level in all steering pumps.

Each Optimus hydraulic pump has a steering fluid reservoir. Ensure the fluid level is between the MIN and MAX marks on the reservoir as shown in the figure below. Use only SeaStar Electronic Power Steering Fluid in the Optimus EPS System.

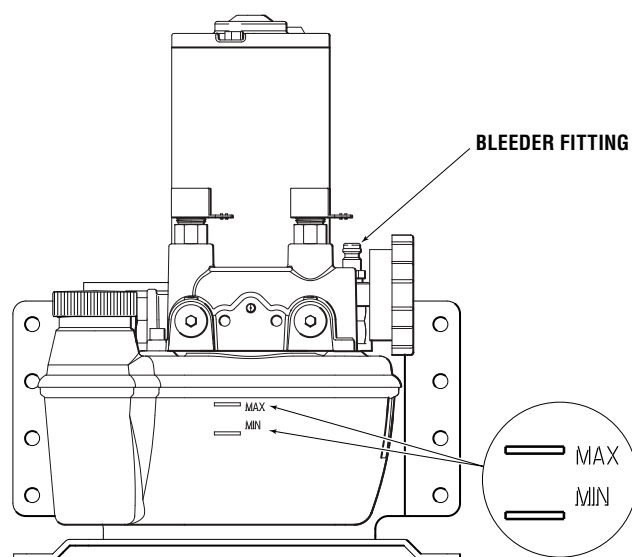

Figure 8-3.

#### 2. Verify immediate steering response when turning steering wheel(s).

Turn on the ignition and then slowly turn the steering wheel to port and to starboard and make sure the engines follow the commands. Watch that the hoses and harness move freely without any snags or hang-ups.

#### 3. Inspect all steering hoses, fittings, mechanical cables, and electrical harness for wear, kinks, or leaks.

Check all steering hoses and fittings between the pump, service valves and cylinders for any signs of leakage, kinking, wear or chafing. Check all electrical and mechanical cabling for abrasion, wear, rubbing or chafing. Check that all connections are tight.

#### 4. Check for binding, loose, worn or leaking steering or shift/throttle control components.

Check all shift and throttle harness for signs of wear, damage or chafing. Check that all linkages and harness move freely and are not binding or corroded.

**5. Verify proper shift and throttle response for all control handles.**

Check that all shift and throttle levers operate freely and cause the engines to shift accordingly. Put the engines in neutral idle mode and confirm that the throttle responds correctly and returns to idle.

**6. Verify that no alarms or warnings are shown on the CANtrak display.**

If any warnings are found, follow the instructions on the CANtrak screen before proceeding.

Read the System Inspection steps on the CANtrak display and acknowledge them by pressing the right hand most button under OK.

**7. Verify that installation checks have been performed per Section 8.1.**

## 8.3 Sea Trial

### **⚠ WARNING**

**ALWAYS WEAR A PFD AND CONNECT THE ENGINE LANYARD(S) TO THE OPERATOR DURING SEA TRIAL.**

### **⚠ WARNING**

**PROCEED CAREFULLY TO DEEP, OPEN WATER TO CONDUCT SEA TRIAL.**

### **8.3.1 Verify Tachometer Signal**

Look at the CANtrak display's main run screen and verify that both port and starboard engine RPM is displayed correctly. Check the displayed values against the engine tachometer gauges on the dash.

If the RPM is not displayed, or the reading is incorrect, check section 6.5 and section 7.1 and ensure that the RPM source was correctly installed and configured in the setup.

### **8.3.2 Check Steering Performance**

Spend some time at low speeds getting used to the steering feel. Steer from lock to lock and check that the engines steer smoothly and with no interference. Hit the hardstops and check that the helm locks solidly. Spend some time in reverse gear as well, and get used to the performance when backing up the vessel. If you have multiple helm stations, steer the boat from all helms.

### **⚠ WARNING**

**USE EXTREME CAUTION WHEN MAKING AGGRESSIVE STEERING INPUTS AT PLANING SPEEDS.**

Once you are familiar with the steering, run the boat at increasing speeds. Check that the steering effort and helm turns change with speed. Check that the steering feels safe, secure and responsive at high speed. Check steering response throughout the typical performance envelope of the vessel.

If you have made an autopilot connection, check that it functions. Set a course and verify that the boat turns and follows the heading. Check that the helm(s) steering effort is high enough to prevent accidental inputs, but low enough that an operator can still manually steer the vessel if required. (Note: it will take an effort to "break" the helm free.) The autopilot's override behavior will depend on the manufacturer; refer to the instructions supplied with the autopilot.

### 8.3.3 Steering Adjustments

---

Now that you have spent some time steering the boat and getting a feel for the steering, you may want to adjust some settings, such as the helm effort and number of turns. See section 7.4 for instructions and a description of the available parameters.

We recommend that you make adjustments in this order:

1. Helm turns at low and high speed
2. Helm effort at low and high speed
3. Low speed engine RPM and high speed engine RPM

Tips:

- In general, you want more helm turns and higher helm effort at high speeds. This reduces the steering sensitivity and increases steering control at speed.
- The recommended low speed engine RPM is the RPM at which the boat starts to plane.
- The recommended high speed engine RPM is the RPM corresponding to wide open throttle.
- On vessels with a large engine center distance (e.g. catamarans) you will find that the Inner/Outer Steering Ratio is a useful parameter to adjust.

#### NOTICE

*Change steering settings in small increments and test each change thoroughly.*

### 8.3.4 Conclusion of Sea Trial

---

Once you are satisfied with the steering settings and the steering performance, and you've verified the tachometer input and autopilot function (when required), the sea trial is complete.

After returning the vessel to port, thoroughly check all hose connections and make sure they are tight. Look for any leaks in the hydraulic portion of the steering system. Check that none of the electrical harnesses and wiring are exposed to water, excessive temperatures, or mechanical damage. Check that all wire splices are properly secured, sealed, and dry. Check that all unused CAN connectors are properly sealed with sealing plugs.

## 8.4 Complete Warranty Checklist

---

The warranty checklist (PID 214740) included with your document package should be completed at this time. It will prompt you to check several important installation points and is a valuable double-check for safety and performance.

Once you have done an orientation with the owner and handed the vessel over, return the completed checklist to SeaStar Solutions for warranty registration.



# 9.0 FAULT HANDLING

The PCM has red LED fault indicators directly under the power LED indicators. Flashing Red indicates a fault. System faults are saved and can be read with Datalink.

Note: During an installation it is common to have some “occurred” RFU related errors. These can be cleared.

1. Using Datalink navigate to the Faults tab.
2. Active and occurred faults will be listed.

## 9.1 Danger Fault Handling

A danger fault is a critical system fault which will result in limited steering performance and requires immediate action and return to the nearest port.

During a danger fault, the CANtrak display will display DANGER across the top, sound a continuous buzzer (until muted) and display fault information and handling in three zones. See the figure below.

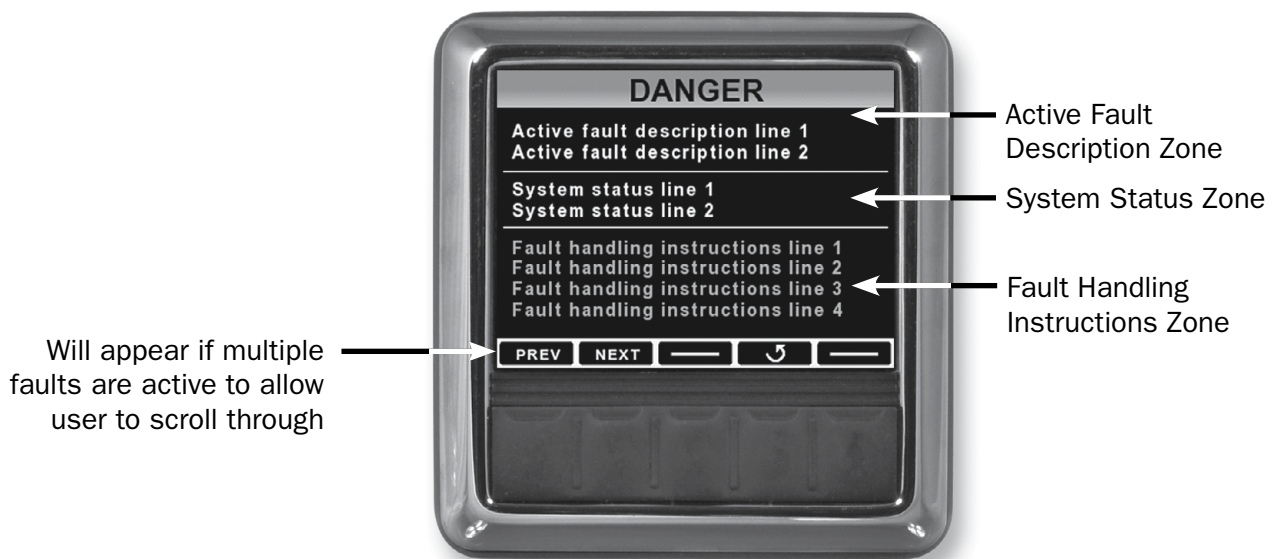

Figure 9-1. Danger Fault screen layout.

### Active Fault Description Zone

Provides details specific to the system fault. These will include a brief description of the fault and are primarily for troubleshooting purposes.

### System Status Zone

Displays information about the status of the system and if the system has automatically reacted to the fault.

### Fault Handling Instructions Zone

Provides detailed instructions on how to proceed. In the case of a danger fault, this will instruct the operator what to do and how to proceed should Limp Home mode be required.

## 9.2 Warning Fault Handling

A warning is a non-critical system fault which will either maintain full steering system operation or cause the steering speed to be reduced. During a warning fault, the CANtrak will display the same information as with a danger fault but WARNING will appear across the top of the screen and the buzzer will sound intermittently (until muted). See the figure below.

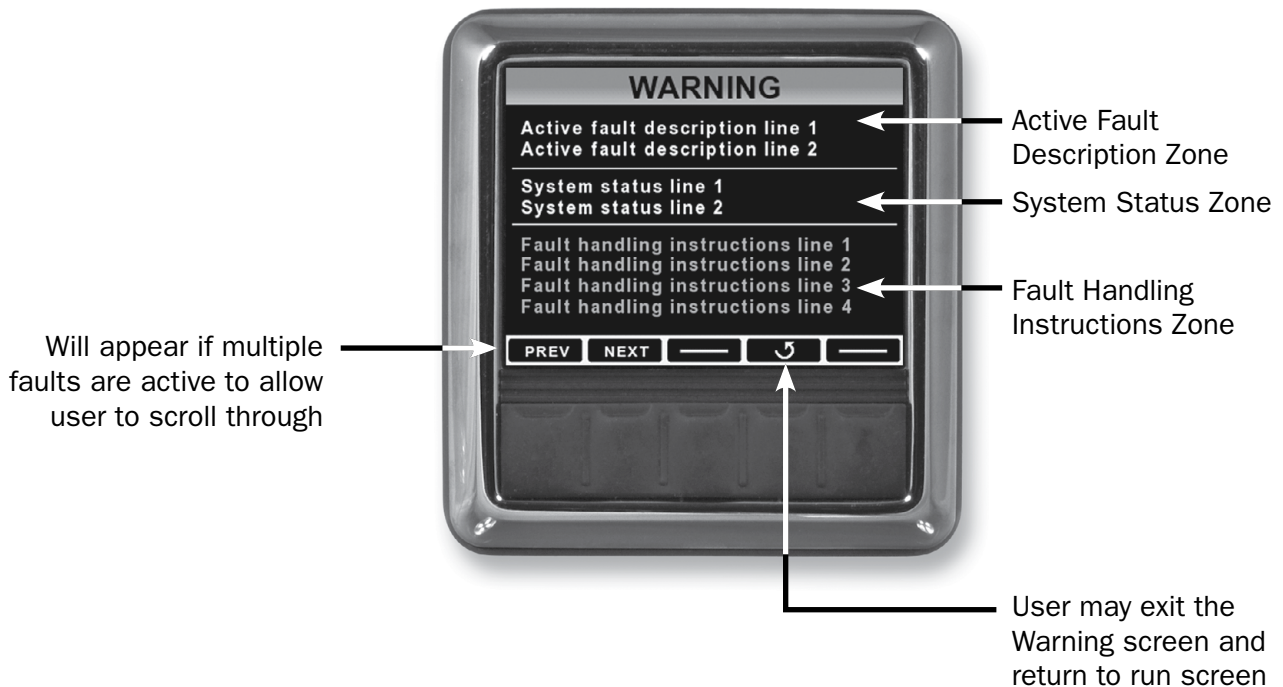

Figure 9-2.

The operator may choose to exit the Warning screen and return to the All Helms Active screen by pressing the exit button, in which case the system will flash a warning icon on the run screen as shown on the next page. This icon will remain in place until the fault is repaired. If the system recovers from the fault, for example if a battery runs low and is subsequently charged, the warning screen will disappear and the system will automatically resume normal operation.

Although the system may still operate normally under many warning faults, the vessel should still be returned to port and serviced immediately.



Figure 9-3. Run screen with system warning.

Some system faults may result in a reduced steering response warning. This means that the system will continue to steer normally but may respond slower.

**NOTICE**

Additional fault handling information is provided in the User's Manual.

*This page left intentionally blank.*

# 10.0 WARRANTY

## 10.1 Statement of Limited Warranty

We warrant to the original retail purchaser that **Marine Canada Acquisition Inc. DBA SEASTAR SOLUTIONS** (herein forward referred to as **SEASTAR SOLUTIONS**) products have been manufactured free from defects in materials and workmanship. This warranty is effective for two years from date of purchase, excepting that where **SEASTAR SOLUTIONS** products are used commercially or in any rental or income producing activity, then this warranty is limited to one year from the date of purchase.

We will provide replacement product without charge, for any **SEASTAR SOLUTIONS** product meeting this warranty, which is returned (freight prepaid) within the warranty period to the dealer from whom such product were purchased, or to us at the appropriate address. In such a case **SEASTAR SOLUTIONS** products found to be defective and covered by this warranty, will be replaced at **SEASTAR SOLUTIONS's** option, and returned to the customer.

The above quoted statement is an extract from the complete **SEASTAR SOLUTIONS** products warranty statement. A complete warranty policy is available in our **SEASTAR SOLUTIONS** products catalogue.

## 10.2 Return Goods Procedure

Prior to returning product to **SEASTAR SOLUTIONS** under warranty, please obtain a *Return Goods Authorization number* (claim number).

Be sure to label the goods with:

- a) the name and address of the sender, and
- b) the return goods authorization number (claim number)

Please address the returned goods as follows:

**From U.S.A.**

RGA # ?  
SeaStar Solutions  
c/o UPS-SCS  
19308 70th Ave S.  
Kent, WA 98032

**From Canada**

RGA # ?  
SEASTAR SOLUTIONS  
3831 No.6 Road  
Richmond, B.C.  
Canada V6V 1P6

---

### Technical Support

Phone: 604-248-3858

email: [seastar@seastarsolutions.com](mailto:seastar@seastarsolutions.com)

Hours: Monday to Friday 05:00 – 15:30 PST

Web: [www.seastarsolutions.com](http://www.seastarsolutions.com)

*This page left intentionally blank.*

# APPENDIX A MOUNTING TEMPLATES

## A.1 Helm Templates

### A.1.1 Front Mount Helm

**NOTICE**

*If this template has been downloaded electronically or copied from another document, please verify all template dimensions prior to cutting. Print/copy reproductions may be scaled differently.*

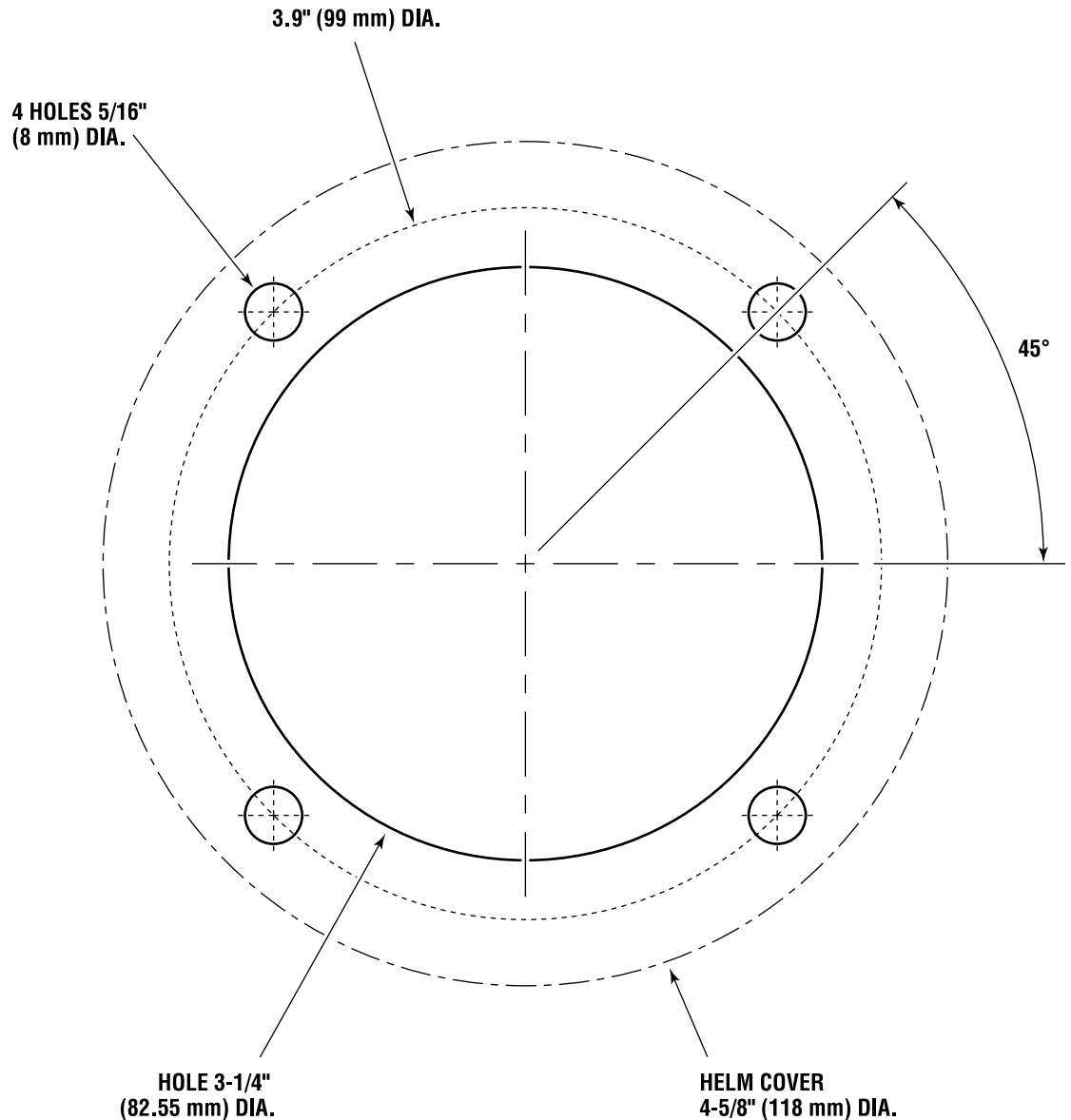

Figure A-1.

*This page left intentionally blank.*



## A.1.2 Rear Mount Helm

### NOTICE

If this template has been downloaded electronically or copied from another document, please verify all template dimensions prior to cutting. Print/copy reproductions may be scaled differently.

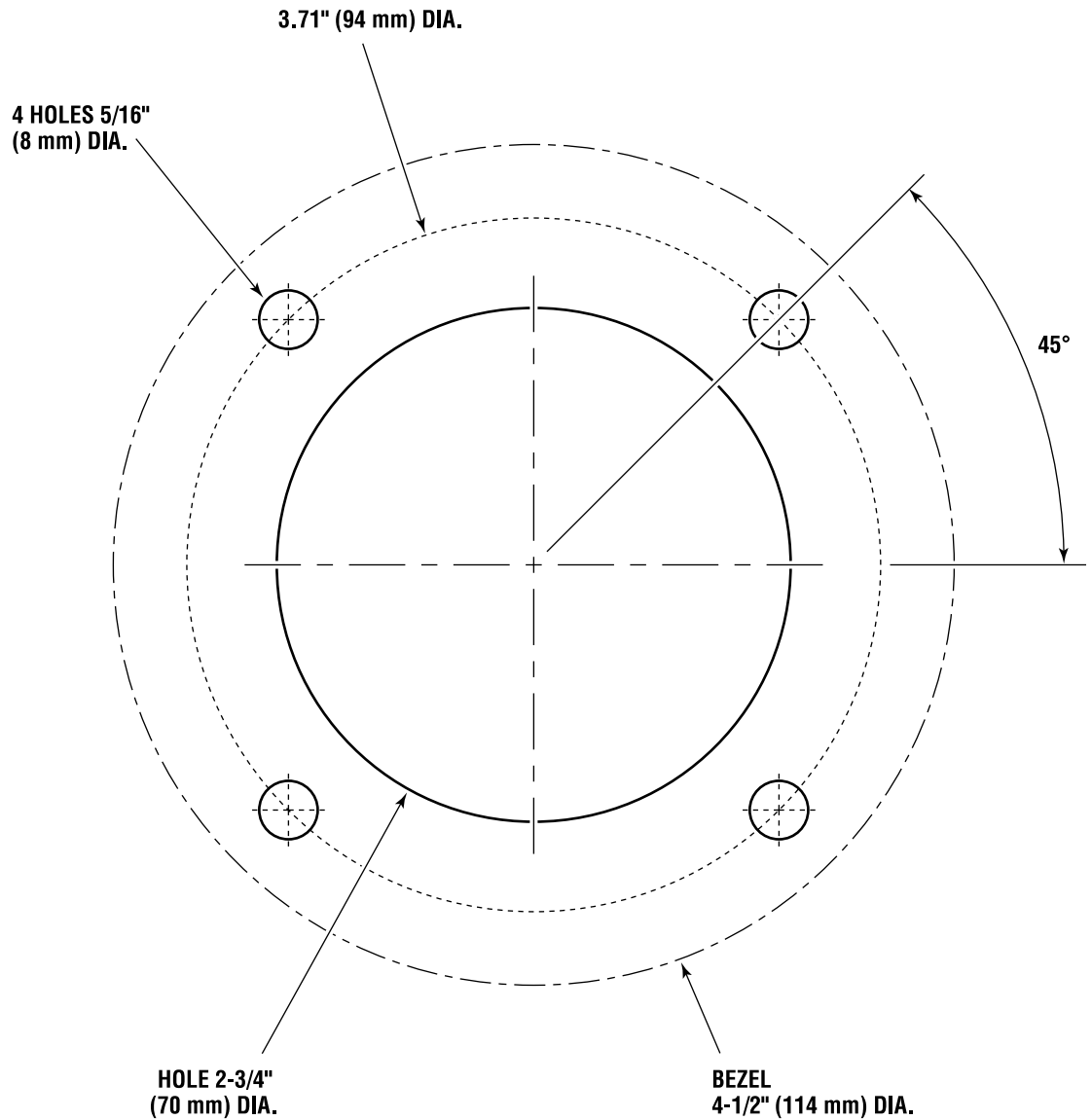

Figure A-2.

*This page left intentionally blank.*

### A.1.3 Classic Tilt Helm

#### NOTICE

If this template has been downloaded electronically or copied from another document, please verify all template dimensions prior to cutting. Print/copy reproductions may be scaled differently.

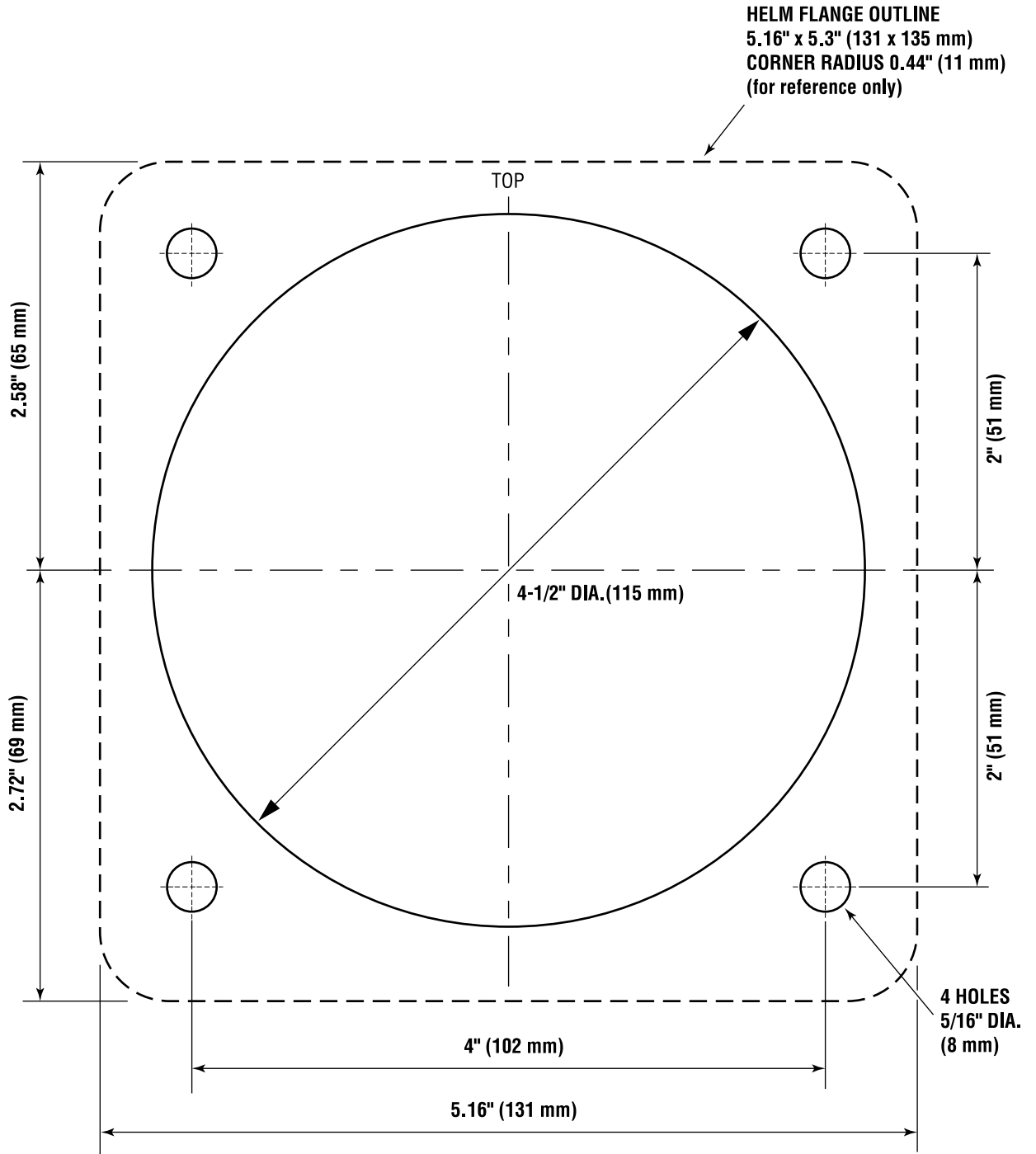

Figure A-3.

*This page left intentionally blank.*

## A.1.4 Sport Tilt Helm

### NOTICE

If this template has been downloaded electronically or copied from another document, please verify all template dimensions prior to cutting. Print/copy reproductions may be scaled differently.

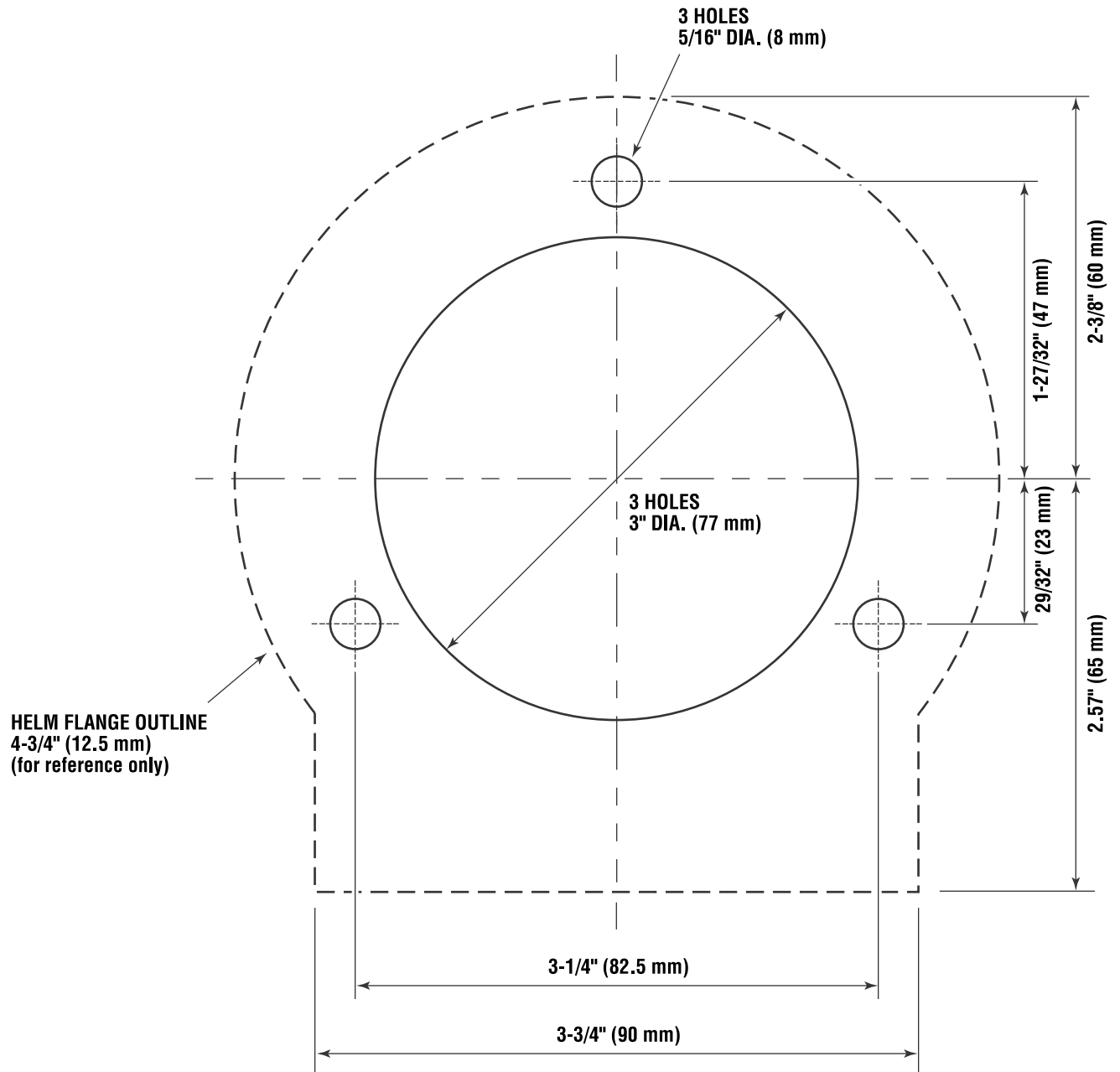

Figure A-4.

*This page left intentionally blank.*

## A.2 CANtrak Display

### NOTICE

If this template has been downloaded electronically or copied from another document, please verify all template dimensions prior to cutting. Print/copy reproductions may be scaled differently.

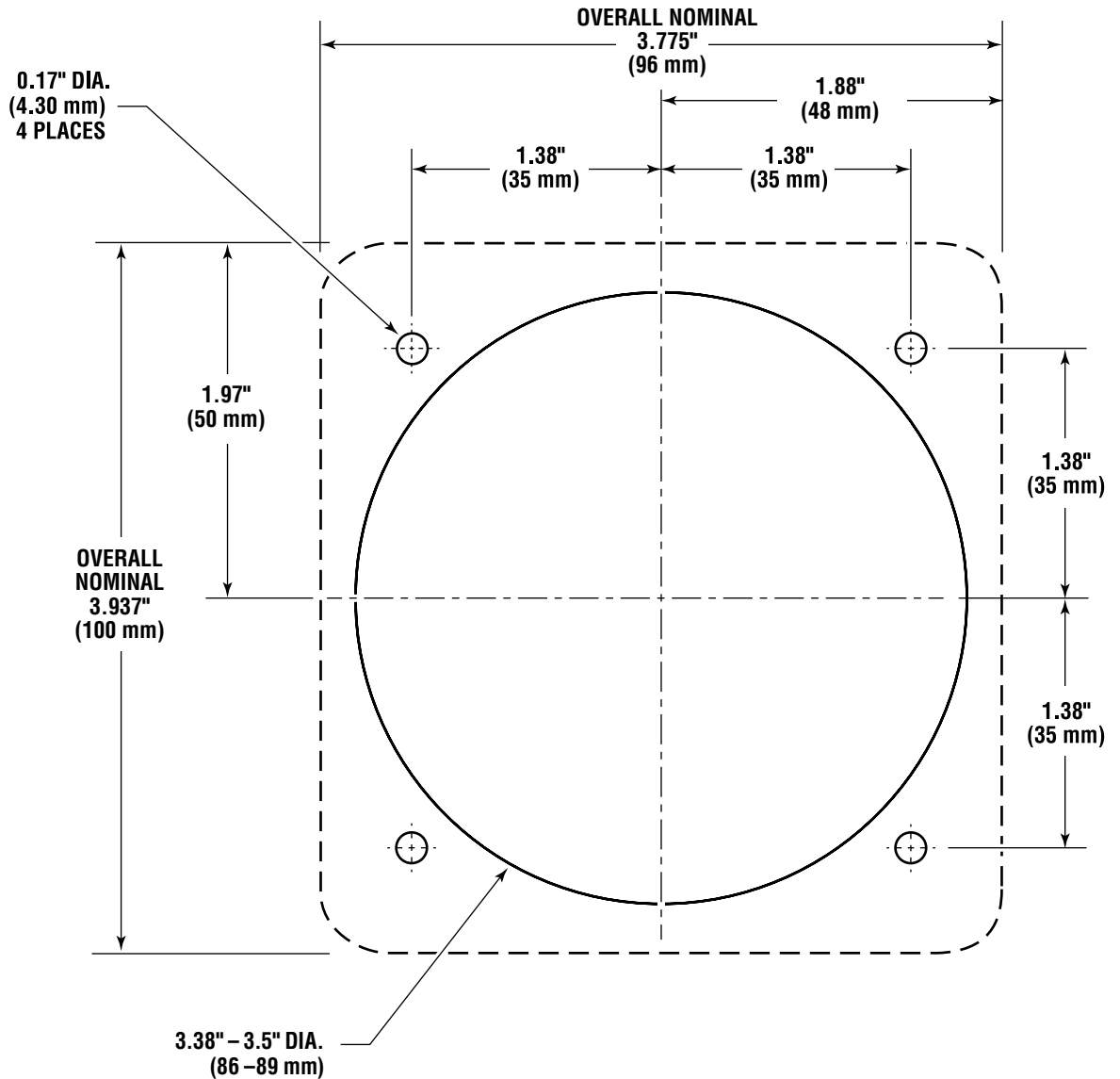

Figure A-5. Color CANtrak Display Mounting Template.

*This page left intentionally blank.*



## A.3 PCM Mounting Dimensions

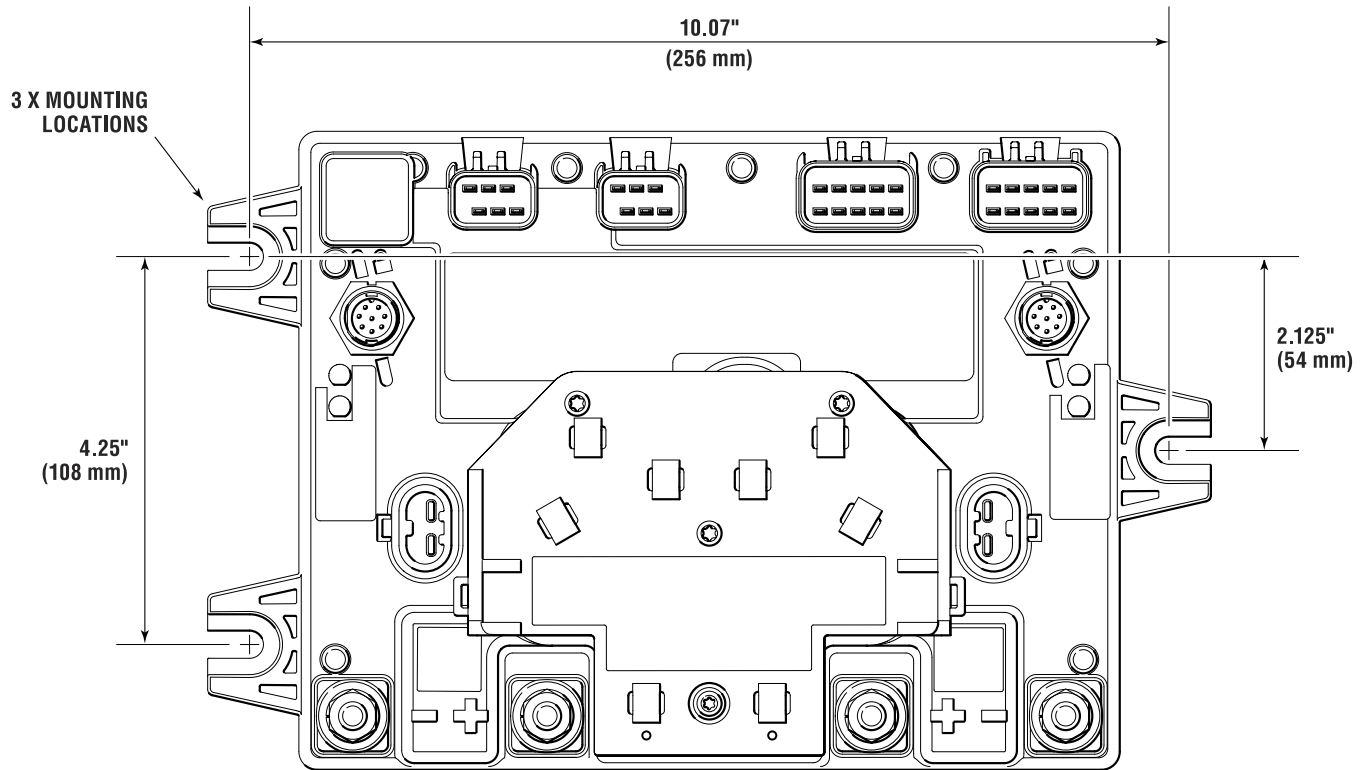

Figure A-6.

## A.4 Power Steering Pump

### A.4.1 Power Steering Pump Mounting Dimensions

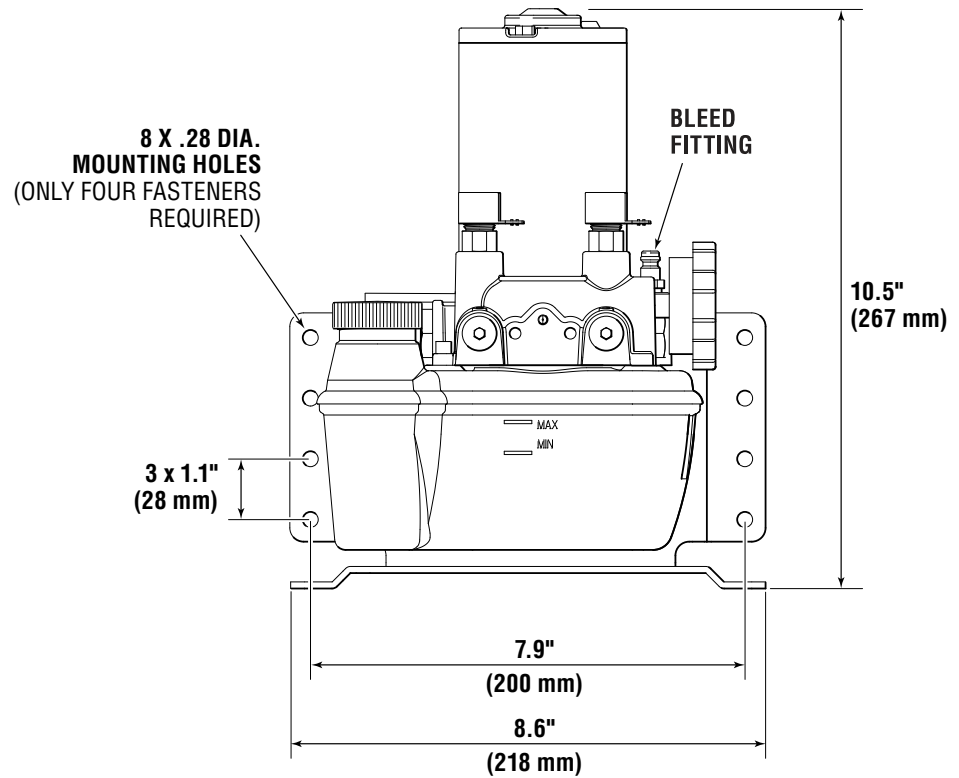

Figure A-7.

## A.4.2 Floor Mounting the Pumps

Recommended Mounting Hardware:

- M6 x 1 cap or machine screw and washer
- 1/4"– 20 cap or machine screw and washer
- #14 wood screw and washer (flat bearing surface under screw head only)

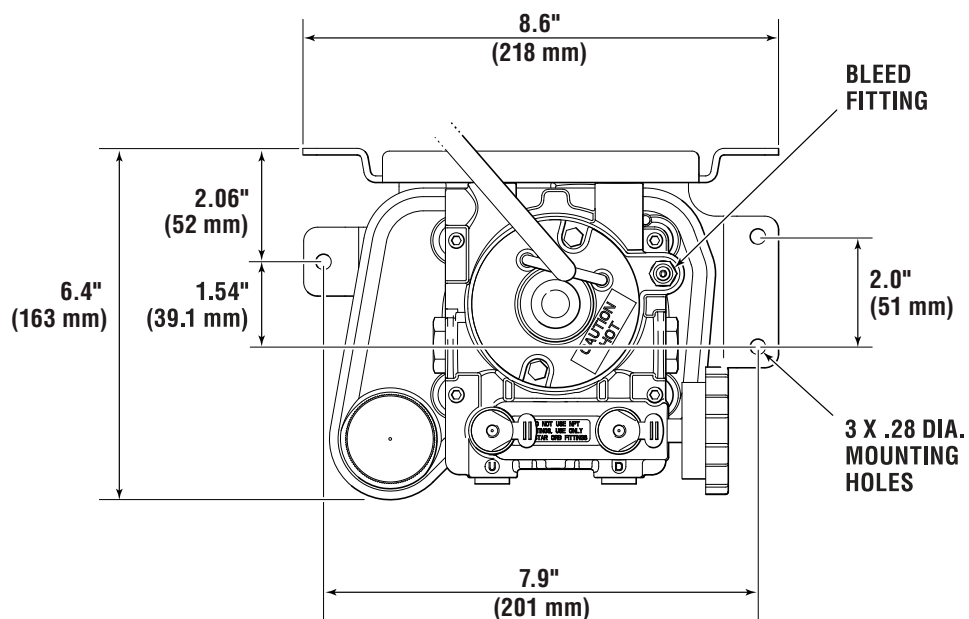

Figure A-8.

*This page left intentionally blank.*

# APPENDIX B CAN NETWORK

## B.1 Basic Network

The NMEA 2000® protocol allows several types of harness. The one shown in this document is the smaller type used in pleasure boats and small vessels. The larger harness is used in shipboard applications. Any manufacturer may use their own harness but to adhere to the standard they must have an adaptor harness that allows easy connection to the approved harness. All SEASTAR SOLUTIONS CAN Bus harness meet the NMEA 2000® standard and will work with any other suppliers' harness that meet the NMEA 2000® standard.

While the NMEA 2000® standard allows separate wires and terminals all CAN Bus harness use the connectors shown in this manual. They are easy to install and result in a high quality, rugged, waterproof installation. The harness should never be cut and spliced.

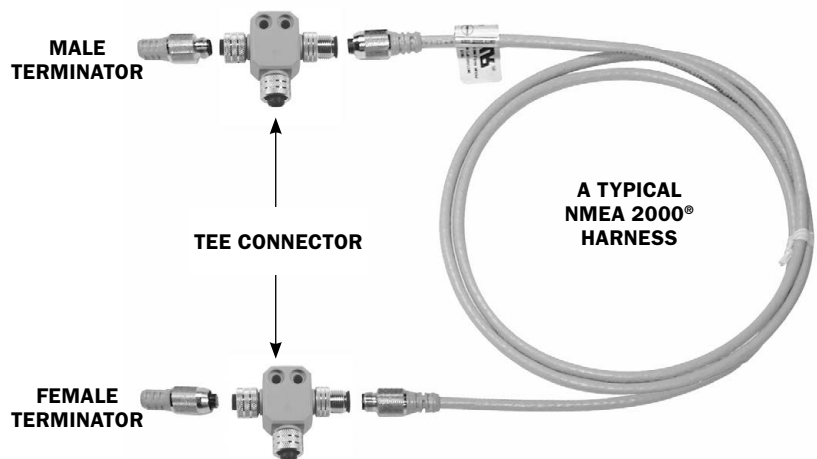

**CM100XX:** A typical NMEA 2000® harness

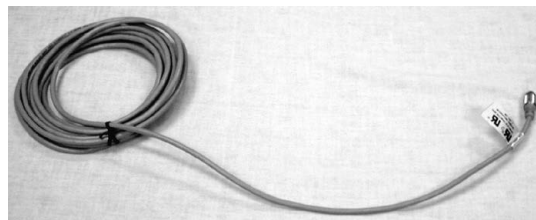

**CM100XX WHERE "XX" EQUALS THE LENGTH OF FEET.  
SEE 4.3.2 FOR PART NUMBERS**

*Figure B-1.*

## B.1.1 CAN Bus Connectors

---

CM10051: MALE TERMINATOR

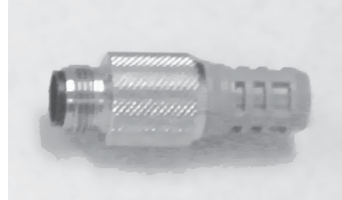

CM10052: FEMALE TERMINATOR

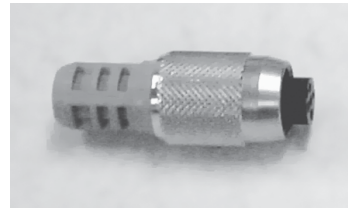

---

Figure B-2.

### Tee Connectors:

Supplied by several vendors. Appearance may vary - parts are interchangeable.

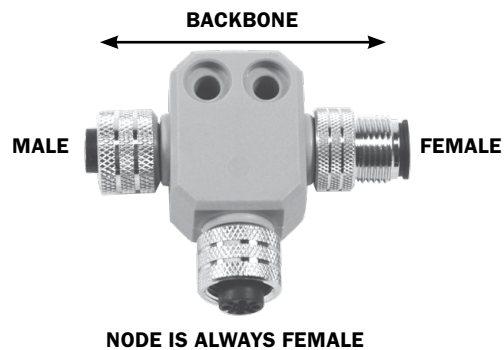

---

Figure B-3. CM10060: Single tee connector.

### Note regarding connectivity of tee connectors:

- When connecting a tee connector to a component always install via the middle connection ("NODE").
- When connecting a tee connector to a CAN Bus harness to connect components that are far from each other, always install via the male/female end of the connector (whichever applies).
- Hand-tighten after the connection is made. **DO NOT** tightly tie down the tee connectors, as this will create stress.

## B.1.2 CAN Bus Connectivity

The Network must consist of a single harness run to which devices are connected by means of a tee connector. All products must connect onto the node part of the tee connector. Each end of the harness must have a terminator. It is essential there be a total of two, and ONLY two, terminators - one located at each end of the backbone.

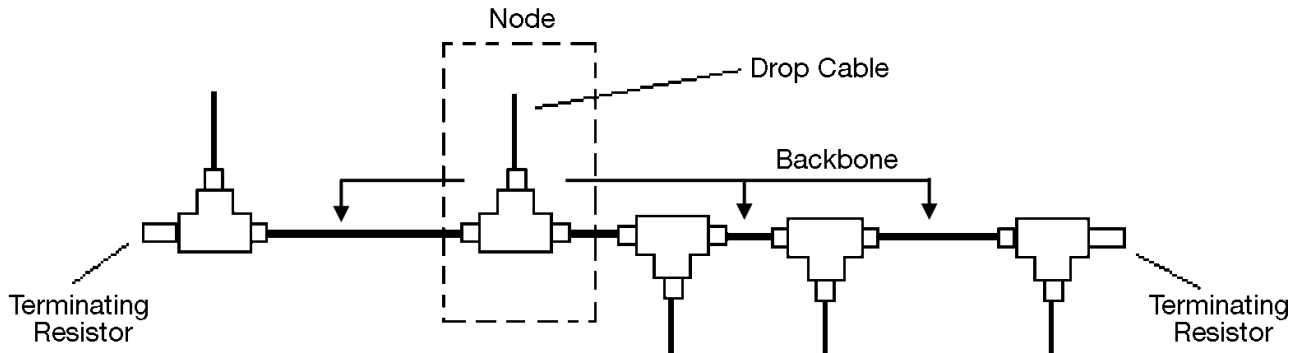

Figure B-4.

**Note-** a tee connector with nothing attached to its node is OK and will not effect the network. NEVER use a terminator to cap the node of an unused tee connector.

## B.1.3 Electrical Harness

### NOTICE

*The electrical harness must not be cut or spliced. Replace worn or frayed harness.*

*When securing the harness and especially when tying down a number of direct connected tees never pull them down so tight as to cause strain or put a curve in the tees as this may cause a failure.*

The cabling that is used conforms to the DeviceNet standard and was developed for Industrial applications. In general the harness are molded and the connection area is sealed with o-ring gaskets to provide a good seal from the environment. The harness are available in a variety of lengths.

**When installing a NMEA 2000® CAN Bus system there are several things to keep in mind:**

- The harness ends are male and female. To avoid a mismatch it is best to work from one end toward the other. If you must work from both ends toward the middle assure that the mating point will be a male/female connection.

- 
- It is wise to plan for expansion. With so many new NMEA 2000® products entering the market and the ability to connect on to the bus for testing it is sometimes wise to use two harness where one would suffice. The connection of the two harness can later be separated so additional tees can be inserted to add another product or test equipment.
  - On 24 volt systems, a DC to DC converter or separate 12 volt battery is required.

---

### **B.1.4 Powering the Bus**

The CAN Bus requires DC power. The voltage range is 9 to 16 volts. The power may be supplied by one or more of the products on the Data Bus or from a separate source. Most equipment manufacturers strongly recommends that at least two independent sources are used to supply the data bus power.

---

### **B.1.5 CAN Bus Power**

The CAN Bus is used to supply power to all the items that are connected on the bus. For items drawing less than one amp, not having any other power connection, or another path back to ground the entire power for the item may be pulled from the CAN Bus. This requires the CAN Bus to have adequate sources of power.

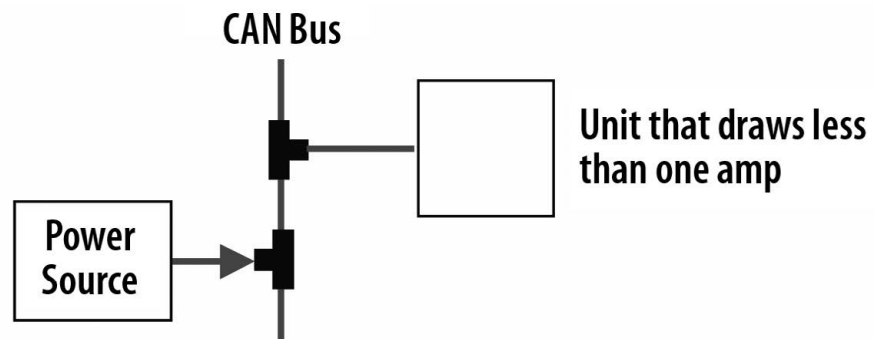

*Figure B-5.*



# APPENDIX C USING DATALINK

Datalink is a software tool that can be used for system setup and configuration. Although most of these functions can be performed with the color CANtrak display, experienced users may find it quicker to use Datalink for these tasks.

## C.1 Dealer Tools

---

To use Datalink with an Optimus system you will need the following items, supplied with kit EPSK1206:

- IXXAT USB to CAN converter, part #214720
- Programming harness, 6-pin FCI to serial, part #CM21010
- Programming harness, DeviceNet to serial, part #CM21106 (used for Optimus 360 systems only)

You will also need a Windows®-compatible notebook computer with Datalink installed on it. See Appendix E for information on how to download and install the latest version of the software.

## C.2 Connection

---

Connect the IXXAT converter to a USB port on your computer, and connect the sub-D connector on harness CM21010 to the IXXAT. Plug the other end of harness CM21010 into an available CAN1 port on the helm or the PCM as shown in figure C-1. If you don't have any spare ports an optional wye harness (CM21702) is available that can convert a single port into two.

### WARNING

**ALWAYS REINSTALL THE CAN1 SEALING PLUGS WHEN YOU DISCONNECT THE PROGRAMMING HARNESS.**

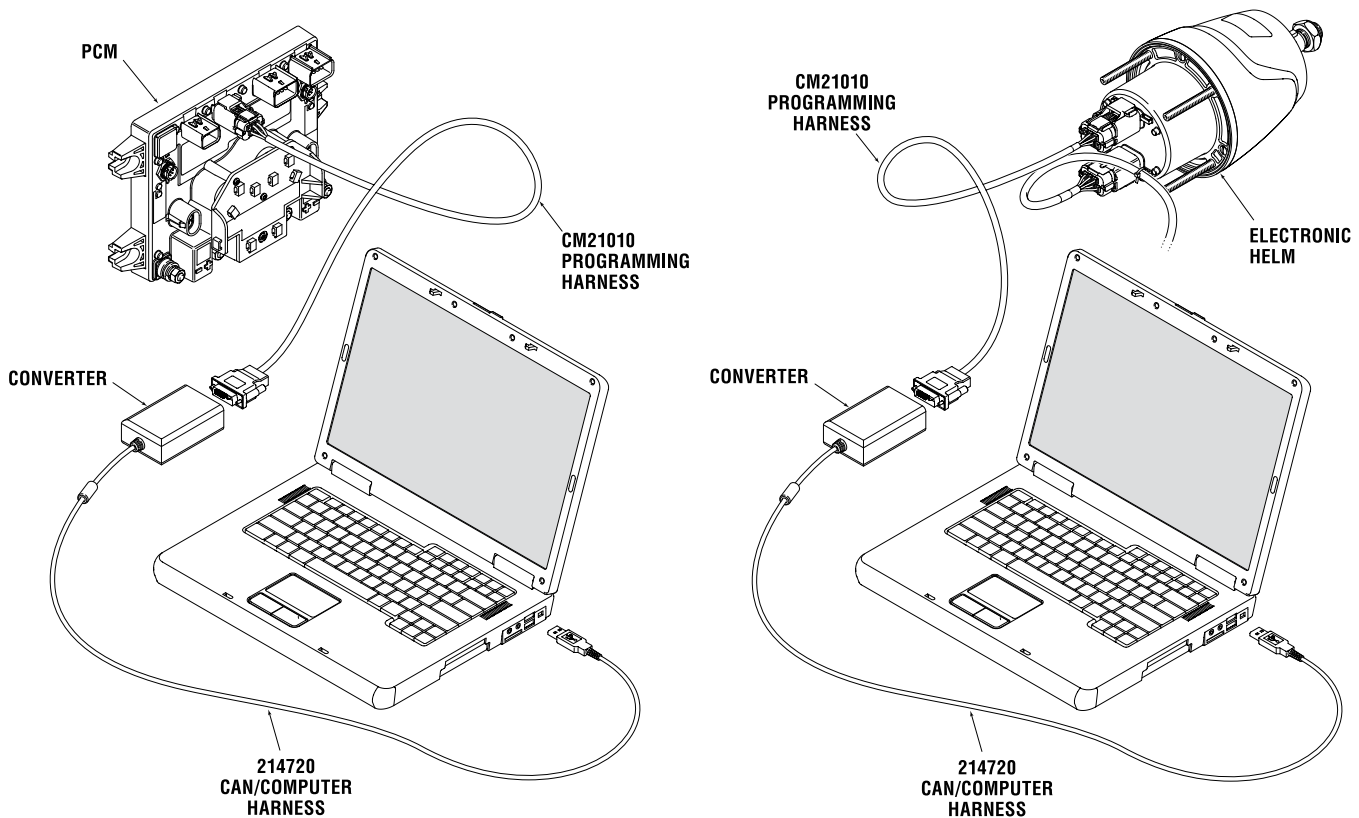

Figure C-1. Connecting programming computer to CAN1.

## C.3 Navigating Datalink

When you run the Datalink software it will open up with a window similar to the one shown in figure C-2.

At the very top of the display is a series of pull-down menus that access various functions. Just below that is the toolbar, which contains buttons for the most commonly used functions.

The pane on the left is called the Workspace. It is your primary access point to the devices in your system. At the top of the workspace is a list of available Interfaces; these are the devices on the network defined by the selected protocol. In the figure you can see under Protocols that 'Optimus CAN2' is highlighted, so the list of Interfaces is a list of devices connected on the CAN2 network.

If you are connected to CAN1, double-click on 'Optimus CAN1' to bring up the connected devices. On an EPS system you should see only the Main PCM, your helm(s), and your display(s).

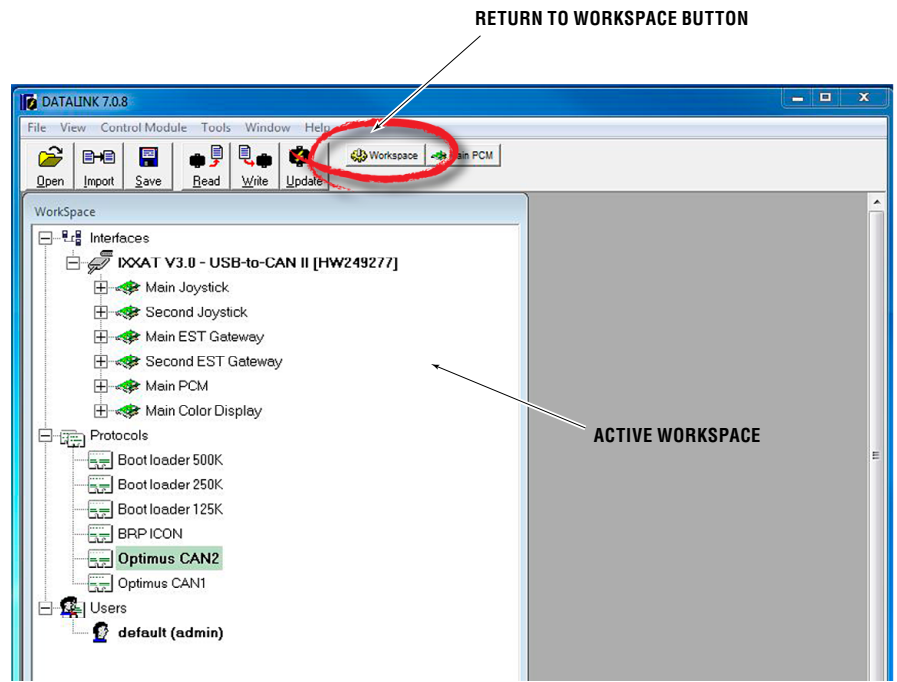

Figure C-2. Datalink Workspace. Your available interfaces may not be exactly as shown.

Double click on a device in the Interfaces list to open the configuration page for that device. Click Workspace in the toolbar at any time to bring up the **Workspace** window.

#### Important notes about Datalink

Datalink is not like most software packages you are used to. Unlike a word processor, you don't open a file, make changes, and save them. Instead, you open an Interface, which is actually a database that is specially formatted on your screen. The parameter fields (any box with editable values) are cross-referenced to data tables in the devices, but it is not in real-time.

What this means is that the parameters you see are just a snapshot of what is in the device. If you edit these parameters on screen, the changes exist only in Datalink. They will not exist in the device until you click the **Write** button on the toolbar. **Write** takes all the database values that exist in Datalink and copies them to the device, where they are saved in nonvolatile memory (i.e. memory that is not lost when power is removed).

Similarly, clicking **Read** will copy parameters from the connected device into the Datalink database, allowing you to see the current state of the actual device. This is a good way to check that any changes you make have been correctly copied to the device.

For this reason, you will generally not need to use the **Open** and **Save** buttons on the toolbar. They have a different function in the context of Datalink, and aren't used for editing parameters. Likewise, if you are prompted to save changes when you close an Interface, just click **No** and exit. The save function has nothing to do with whether the changes are saved on your device.

## C.4 System Setup

Basic system configuration is set through the color CANtrak display parameters. The display then broadcasts these settings to all the system devices connected to the network.

Access the parameters by double-clicking on Main Color Display in the Datalink workspace, then clicking on the Configuration tab. Remember to click **Write** after making any changes.

### C.4.1 System Parameters

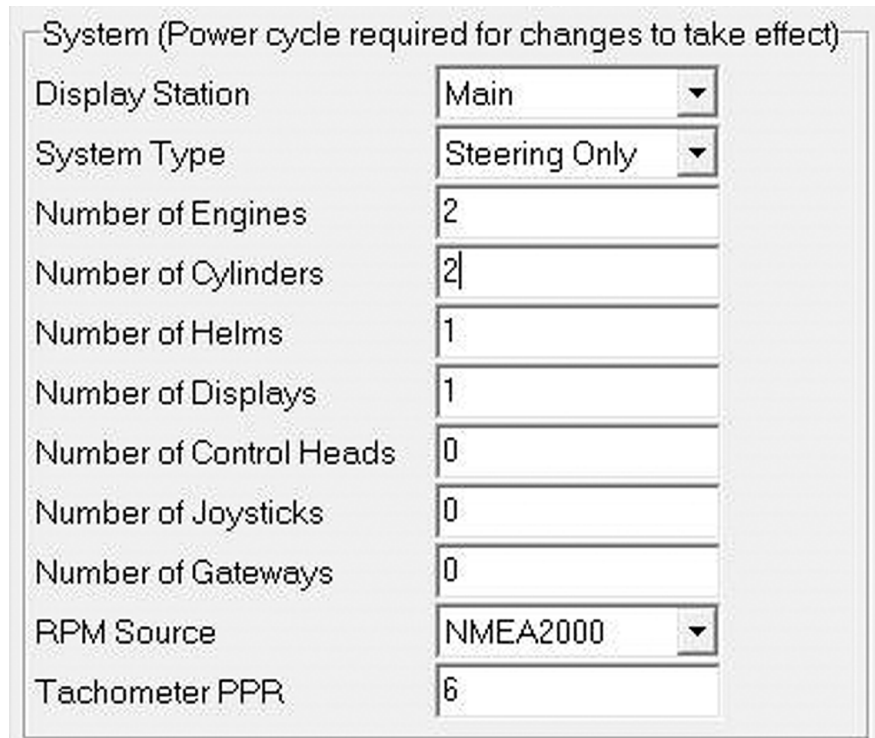

System (Power cycle required for changes to take effect)	
Display Station	Main
System Type	Steering Only
Number of Engines	2
Number of Cylinders	2
Number of Helms	1
Number of Displays	1
Number of Control Heads	0
Number of Joysticks	0
Number of Gateways	0
RPM Source	NMEA2000
Tachometer PPR	6

Figure C-3. Color display – System parameters.

<b>Display Station</b>	Set the instance of the display. The default is Main; you only need to change the second station display instance.
<b>System Type</b>	Select 'Steering Only' from the drop-down list.
<b>Number of Engines and Cylinders</b>	For Optimus EPS systems the number of engines and cylinders is assumed to be two, and these parameters are ignored.
<b>Number of [component]</b>	Enter the quantity of helms and displays in your system. The other components do not apply on an Optimus EPS system.
<b>RPM Source</b>	Set to the appropriate RPM source.
<b>Tachometer PPR</b>	If you're using an analog tachometer, you may need to adjust the PPR setting.

## C.4.2 Settings Menu Access

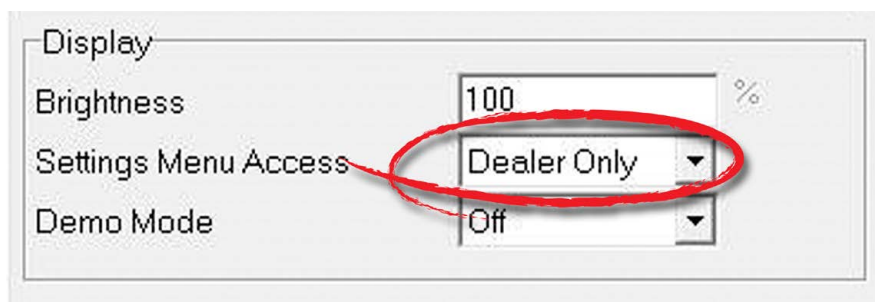

Figure C-4. Display parameters.

The adjustable steering settings are limited to those with Dealer Menu access by default. To allow users to adjust the steering settings, change the Settings Menu Access parameter to 'All'.

## C.4.3 Second Station

If you have a second control station, you need to open the interface for the second station helm and change its instance to 'Second'. Click **Write** to save the change.

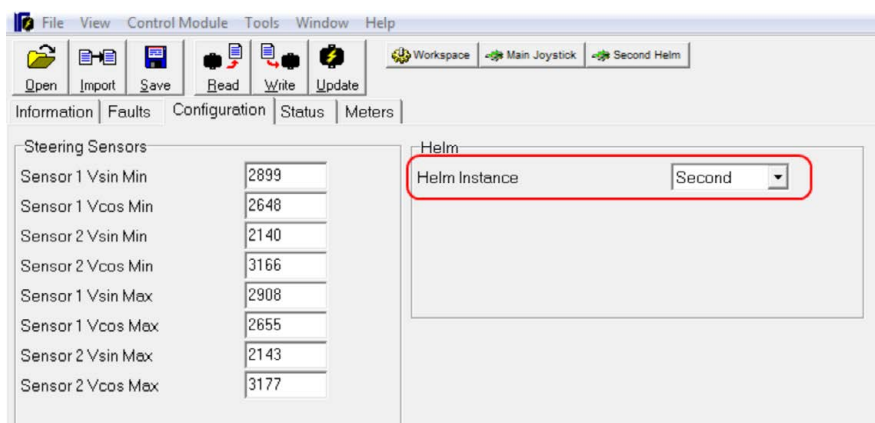

Figure C-5. Helm Configuration Screen.

You will also need to configure the second station display. See section C.4.1 and change the second display's Display Station parameter to 'Second.'

## C.4.4 Cycle Power to System

Changes to system parameters will not take effect until the power has been cycled.

To cycle power, turn the key off for several seconds and turn it on again.

## C.5 Purge with Datalink

The physical procedure for purging is identical to the steps shown in section 7.2, but instead of using the display to set the system into Purge mode, you will use Datalink.

Open the PCM interface and click on the Configuration tab. Find the Purge and Calibration Commands, as shown in figure C-6.

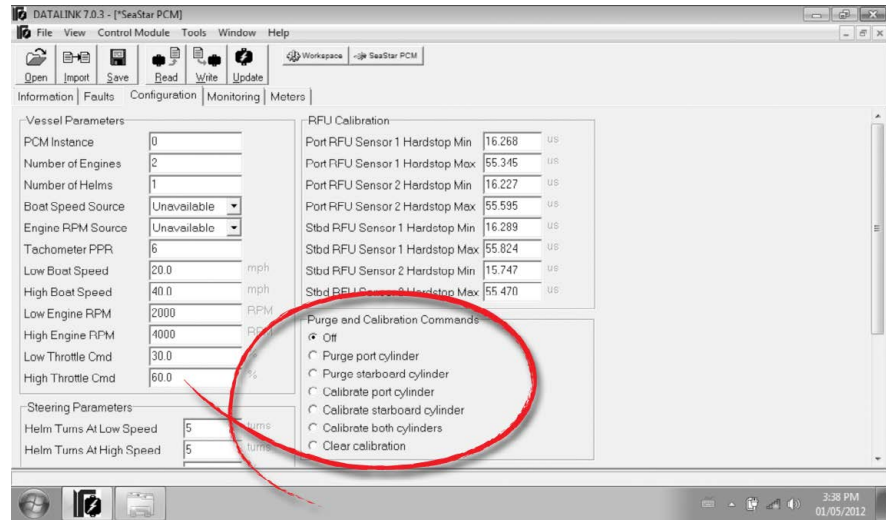

Figure C-6.

In step 8 of the purge procedure (section 7.2) use the radio buttons to set the mode into either 'Purge port cylinder' or 'Purge starboard cylinder'. To take the system out of purge mode, click the radio button next to 'Off'.

## C.6 Calibrate with Datalink

### ⚠ WARNING

**DURING THE CALIBRATION PROCEDURE THE ENGINES WILL MOVE THE FULL TRAVEL OF THE STEERING RANGE. CONFIRM THERE ARE NO OBSTRUCTIONS IN THE PATH OF THE ENGINES. IF THERE IS AN OBSTRUCTION REQUIRING STROKE REDUCTION, THE CYLINDER MUST FIRST BE CALIBRATED WITH THE SUPPORT BRACKETS REMOVED.**

### ⚠ CAUTION

**The Optimus EPS system must be fully purged of air before calibration is attempted. Any air in the system will prohibit calibration and will cause the system to exhibit faults.**

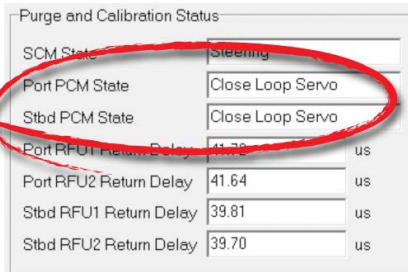

Purge and Calibration Status		
SCM State	Steering	
Port PCM State	Close Loop Servo	
Stbd PCM State	Close Loop Servo	
Port RFU1 Return Delay	41.76	us
Port RFU2 Return Delay	41.64	us
Stbd RFU1 Return Delay	39.81	us
Stbd RFU2 Return Delay	39.70	us

Figure C-7.

1. Open the starboard service valve, move the starboard engine as far outboard as possible, then close the service valve again. This will prevent collision when the port engine moves during calibration.
2. Open the PCM interface and click on the Configuration tab. Find the Purge and Calibration Commands, as shown in figure C-6.
3. Click the radio button labeled 'Calibrate Port Cylinder'.
4. Turn the helm to starboard until the Port PCM State in Datalink reads 'Calib.Hardstop Reached'.
5. Turn the helm to port until the Port PCM State in Datalink reads 'Calib.Hardstop Reached'. Leave the engine at the port hardstop to prevent contact between engines when calibrating the starboard cylinder.
6. Select 'Calibrate Starboard Cylinder'.
7. Turn the helm to starboard until the Stbd PCM State in Datalink reads 'Calib.Hardstop Reached'.
8. Turn the helm to port until the Stbd PCM State in Datalink reads 'Calib.Hardstop Reached'.
9. Turn off the system for 2-4 seconds.
10. Power up the system and turn the helm. The engines should align automatically, and the steering should operate normally. You may see a window in Datalink asking you if you wish to save changes. Click **No** and exit.

*This page left intentionally blank.*



# APPENDIX D USING THE COLOR CANtrak DISPLAY

The color CANtrak display is used to display system status and fault information. It is also a powerful tool that can be used to set up the Optimus EPS system, purge and calibrate the SmartCylinders, adjust steering parameters, and perform software updates.

## D.1 Display Navigation

The five buttons at the bottom of the unit are used to select various actions. The five boxes at the bottom of the display screen will indicate the legend for each button. These legends vary based on what is on the screen.

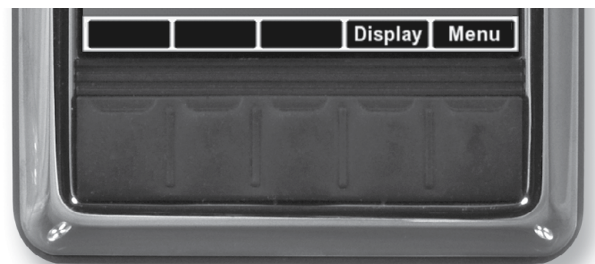







Figure D-1. Navigation buttons and legend.

<b>WORD OR SYMBOL</b>	<b>IDENTIFIES A FUNCTION OR SETTING</b>
	Moves the cursor up the screen to the next item.
	Moves the cursor down the screen to the next item.
	Enters the sub-menu at the cursor location.
	Reduces the setting of the selected item.
	Increases the setting of the selected item.
<b>OK</b>	Accepts a given statement or condition and advances to the next screen.
	Returns to previous menu.
<b>Save</b>	Saves change and returns to previous menu.

## D.2 Documentation Conventions

To keep the instructions in the manual as simple as possible, we will use some simple conventions to describe the navigation through the menus. By using these conventions we can easily direct you through several levels of the menu structure.

**Bold text** Indicates actions that you take on the display. These actions may be button presses, or they may be menu or parameter names.

Capitalized Plain Text Refers to menu and parameter names when describing them.

> When used with the word “press”, refers to the button under the > symbol.  
When chained together with text, it is guiding you to select the next item in the chain.

Examples: Press **Save** to save changes and return to the Settings menu.

Navigate to **Dealer Menu > Initial Setup > Steering** to access the System Setup menu.

Let’s look closely at the second example, illustrated in figure D-2.

**Dealer Menu** tells you to start from the Dealer Menu.

**> Initial Setup** tells you to highlight the Initial Setup menu item and press > to enter the menu.

**> Steering** tells you to highlight the Steering item and press > to enter the menu.

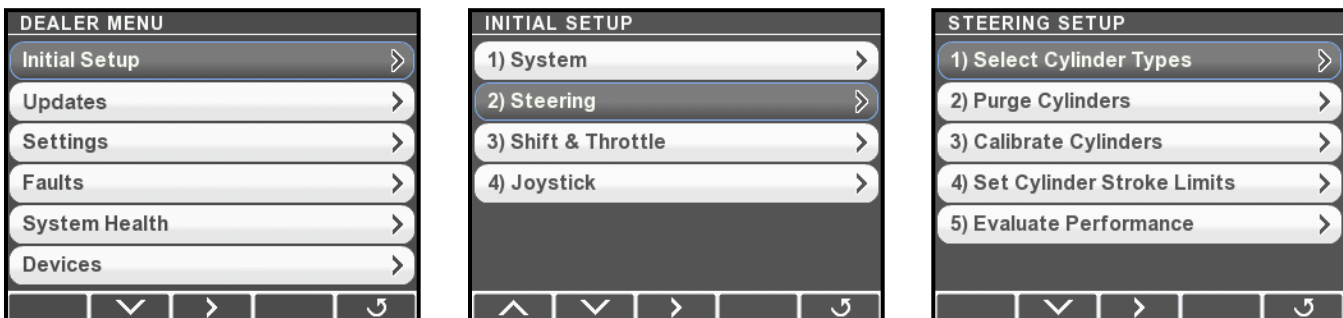

Figure D-2.

You’ll notice that you needed to use the down navigation arrow to select Steering on the Initial Setup screen. You will frequently need to use the up and down arrows to select menus and parameters, but these actions will not be explicitly described.

## D.3 Initial Startup

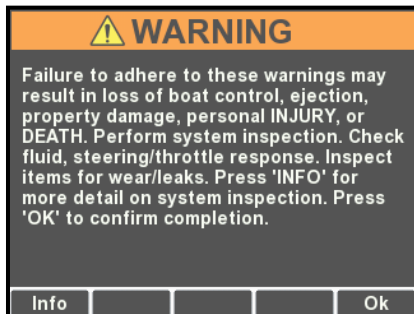

Figure D-3.

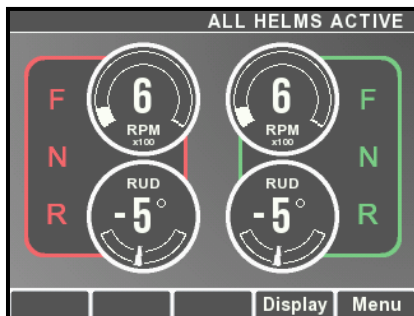

Figure D-4.

When the system power is turned on the CANtrak will display a splash screen, followed by an initial warning screen that prompts the user to perform a system inspection.

Press **Info** to step into the system inspection prompts, or press **OK** to continue. This will take you to the main run screen (also called the All Helms Active screen). If you press **Menu** from the main run screen you will see menus available to the user. (The screen shown is for an Optimus 360 system with joystick – on an EPS system you will not see the gear selection.)

## D.4 Unlocking the Dealer Menu

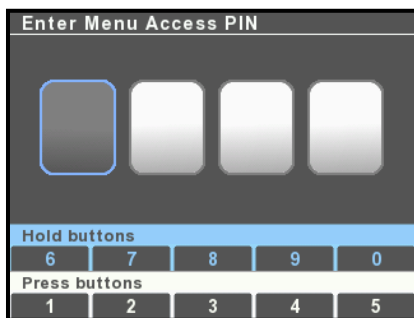

Figure D-5.

All setup and configuration tools are reached from the Dealer Menu, which authorized installers can access with a four digit PIN code (if you don't have a code contact SeaStar Solutions technical support). From the main run screen, press and hold **Menu** until you see the PIN entry screen.

Use the buttons to enter your four digit PIN code. Press the buttons briefly for digits 1-5, press and hold for digits 5-9.

If you enter the code incorrectly you will exit the screen and be placed into the user menu. Press and hold **Menu** again to get back to the PIN entry screen.

Once you have entered the correct code you will go directly to the Dealer Menu. You won't need to enter the code again unless you cycle system power.

### NOTICE

*The Dealer Menu can be unlocked when faults are active. Faults are suppressed during setup and system updates.*

## D.5 Menu Structure

The CANtrak display is built with smart menus. The options that are available to you will depend on the system type you set in the initial system setup. The menu structure is extensive, so rather than presenting a map of the entire structure we will highlight the key things you need to know.

### Dealer Menu

The Dealer Menu is the base level menu for access to all of the setup tools. There are six submenus available from this screen.

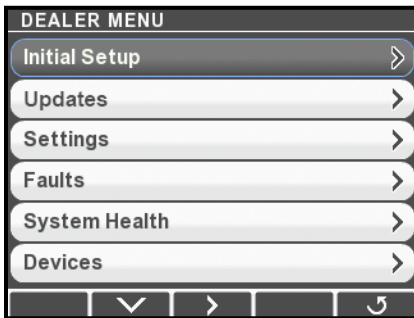

Figure D-6.

### Dealer Submenus

Shaded items are hidden on Optimus EPS (steering-only) systems.

#### INITIAL SETUP

1) System	Set system type, firmware update, set number of devices and their location, select RPM source.
2) Steering	Set cylinder types, purge and calibrate cylinders, set cylinder stroke limits.
3) Shift and Throttle	Adjust shift and throttle settings for Optimus 360 with i6800 EST system.
3) Yamaha EST Gateway	Configure EST gateway for Optimus 360 with Yamaha DEC engines.
3) Suzuki EST Gateway	Configure EST gateway for Optimus 360 with Suzuki SPC engines.
4) Joystick	Joystick tuning for Optimus 360.

#### SETTINGS

System	Control broadcast of RPM and gear selection on CAN3 (NMEA 2000)
Steering	Adjust steering parameters, such as helm effort and number of turns.
Shift and Throttle	Enable station protection and RPM sync, other settings. i6800 EST only.
Yamaha EST Gateway	Yamaha DEC engines only.
Suzuki EST Gateway	Suzuki SPC engines only.
Joystick	Fine tuning for joystick control.
Display	Control user access to steering adjustments.

#### FAULTS

Shows all active faults. A yellow hazard triangle in place of the > arrow indicates that an active fault is present.

#### SYSTEM HEALTH

Displays each connected device with a status icon to indicate health.

#### DEVICES

Lists all devices. From submenu you can find product serial numbers, configure and calibrate the device, monitor inputs and outputs, update firmware, and export or import device settings.

#### TOOLS

Import and export system settings.

### NOTICE

The Dealer Menu can be unlocked when faults are active. Faults are suppressed during setup and system updates.

# APPENDIX E UPDATING FIRMWARE

## NOTICE

*This appendix contains instructions for both Optimus EPS and Optimus 360 systems. If you are working with an EPS system, disregard any reference to the Optimus 360 system or its components.*

From time to time it may become necessary to update the Datalink notebook software and the Optimus component firmware as new versions become available.

## E.1 Downloading Software Update Files

Check [www.optimusdealers.com](http://www.optimusdealers.com) for latest available firmware. The updates are packaged in a single download file called 'Optimus and Optimus 360 Datalink Updater Version X', where X indicates the revision. A readme file describes the nature of the updates, the component revision files included in the package, and any special instructions. We recommend that you read the readme file prior to updating. There is a link to the Readme file on the website, or it can be accessed from the Datalink **Help** menu. Choose **Help > readme.txt** to view the file.

When run, the Updater will first install the latest version of Datalink on your computer, then automatically load the latest firmware files to the notebook computer and put them in the [Desktop\Optimus Firmware] folder. Each component update file will be in a separate folder with the component name. See Figure E-1.

Name	Date modified	Type
Actuator Shift_Throttle	3/27/2014 2:31 PM	File folder
BRP	3/27/2014 2:31 PM	File folder
Color CANTrak	3/27/2014 2:31 PM	File folder
Control_Head	3/27/2014 2:31 PM	File folder
EPS_Helm	3/27/2014 2:31 PM	File folder
Joystick	3/27/2014 2:31 PM	File folder
PCM	3/27/2014 2:31 PM	File folder
Suzuki_EST_Gateway	3/27/2014 2:31 PM	File folder
Yamaha_EST_Gateway	3/27/2014 2:31 PM	File folder

Figure E-1. Desktop\Optimus Firmware – Folder Structure.

**NOTE:** The installer only loads the required files to the computer; it does NOT perform the actual component updates. Refer to Section E.2 for detailed component updating instructions.

## E.2 System Software Update

Both the color CANtrak display and Datalink feature a software update utility that will check each component's revision level and automatically update it to the correct revision level for your system type. Before using the update utility you must have completed the initial system setup shown in section 7.1.

Please note that the update utility does not update the CANtrak display software. It must be updated separately as shown in section E.5.

### NOTICE

*The update utility is not available with the monochrome CANtrak display.*

### E.2.1 Using the Color CANtrak display

### NOTICE

*Before running the software updater the Color CANtrak display software must be updated as shown in section E.5.*

### NOTICE

*The software update will take several minutes to complete.*

### ⚠ WARNING

**ONCE THE UPDATE PROCESS HAS BEEN STARTED CONTINUE UNTIL IT IS COMPLETED. THE VESSEL MAY NOT BE SAFE TO OPERATE BEFORE THE PROCESS HAS FINISHED AND THE FINAL KEY CYCLE HAS BEEN PERFORMED.**

#### Procedure

1. Navigate to **Dealer Menu > Initial Setup > 2) Updates** and press **>**. The system will check the revision level of all installed components and prompt if an update is required. Follow the instructions on the display to complete the update. See figure E-3 for a flowchart of the update process.
2. Once the update is successfully completed and you've performed the final system restart, return to Initial Setup and complete the setup and configuration of the system.
3. If you are updating a system that is already installed and configured, review the configuration of each component and ensure that nothing has changed. This is especially important for the push/pull setting on the shift and throttle actuators. You may need to repeat the setup if there were any export/import errors during the update.

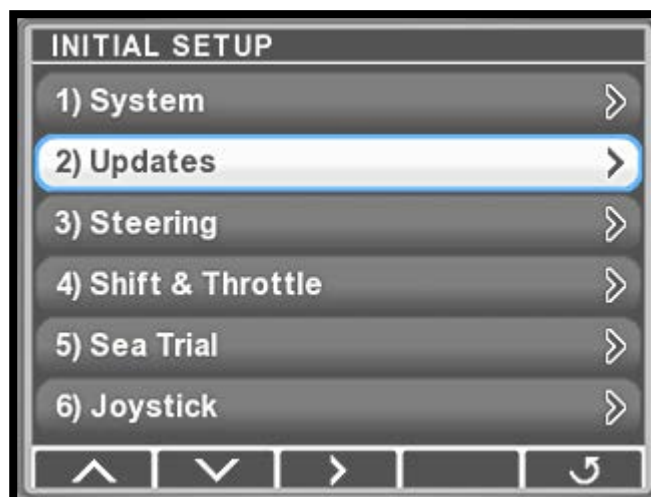

Figure E-2.

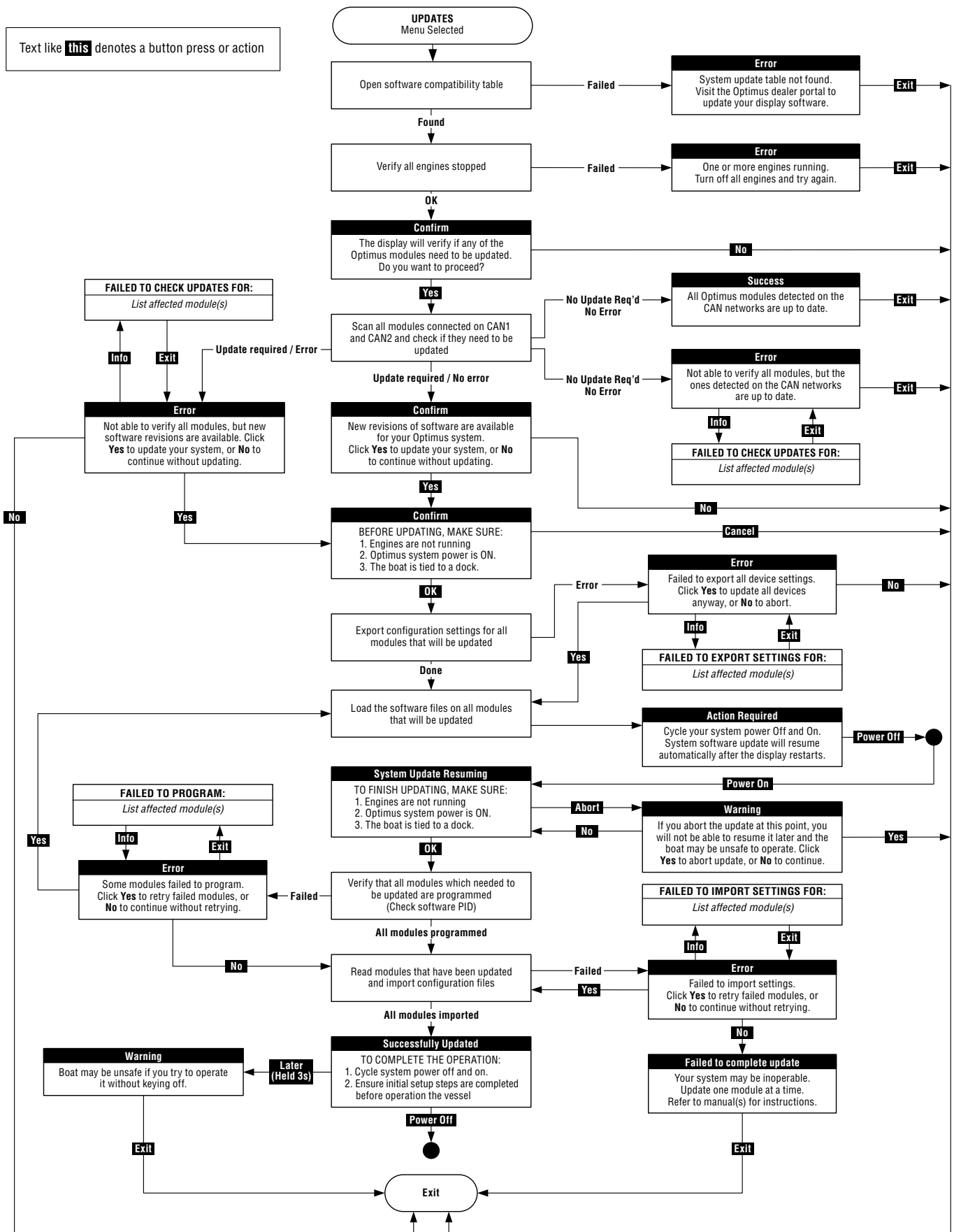

Figure E-3 Software update process using CANtrak.

## E.2.2 Using Datalink

### Procedure

1. Download and install the file updater (section E.1).
2. Connect your computer to the system and open Datalink (Appendix C).
3. Choose **Control Module > Update All** to start the utility.

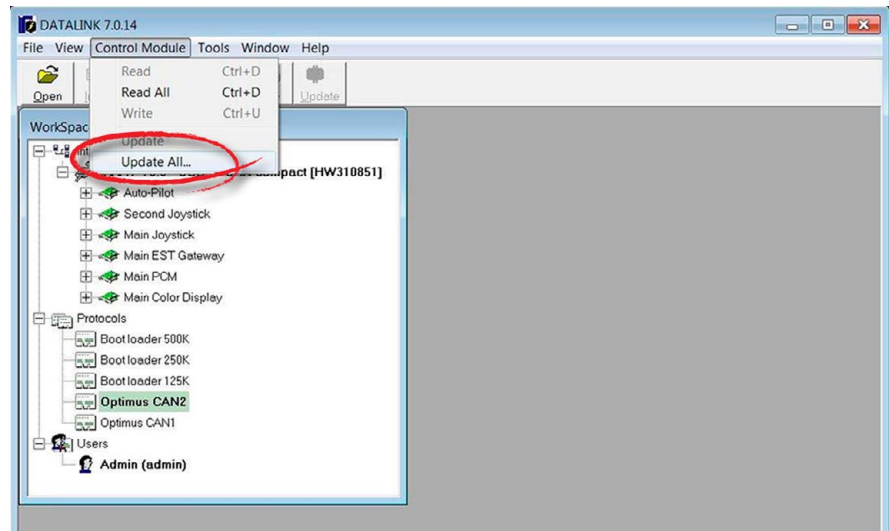

Figure E-4.

4. The program will update all the connected components.
5. Click **Yes** at the confirmation dialogs to continue.
6. When the software reports that the update is complete, close Datalink and cycle the system power.
7. You will still need to update the CANtrak display firmware separately. See section E.5 for instructions.
8. Continue the system setup and configuration. If you are updating a system that is already installed and configured, you may need to repeat the setup if there were any errors during the update. Even if there were no errors, you should review the component setup information and ensure that nothing has changed. This is especially important for the push/pull setting on shift and throttle actuators.



## E.3 Checking Component Firmware Revision Levels

You can check the current firmware revision of each component using the CANtrak display or Datalink.

### E.3.1 Using CANtrak

1. Navigate to **Dealer Menu > Devices > [component name] > Product Information** to go to the Product Information page.

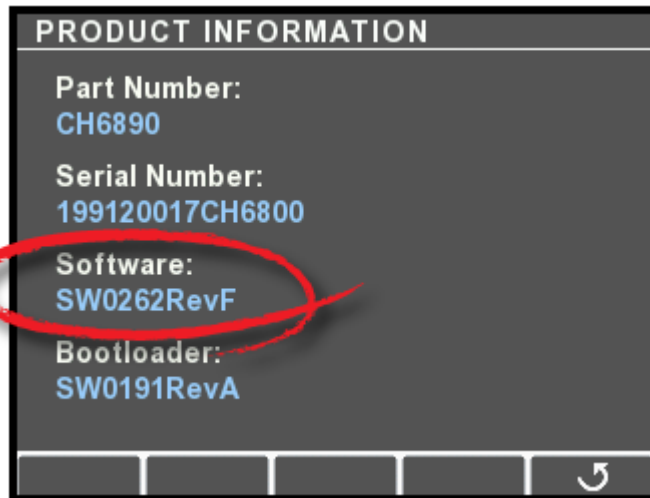

Figure E-5.

2. The software revision is listed, along with the part number and serial number of the component.

### E.3.2 Using Datalink

Connect the computer to the Optimus system as follows:

- Optimus EPS: via CAN1 connection as shown in Appendix C.
  - Optimus 360: via CAN2 connection as shown in the Optimus 360 Installation Supplement (Book 60).
1. In the Interfaces section in Datalink, click on the  box to expand the component information. See figure E-6. (In an EPS system you will see only the PCM and Helm in the component list.)
  2. Firmware revision can be found under the 'Firmware Part Number' field.

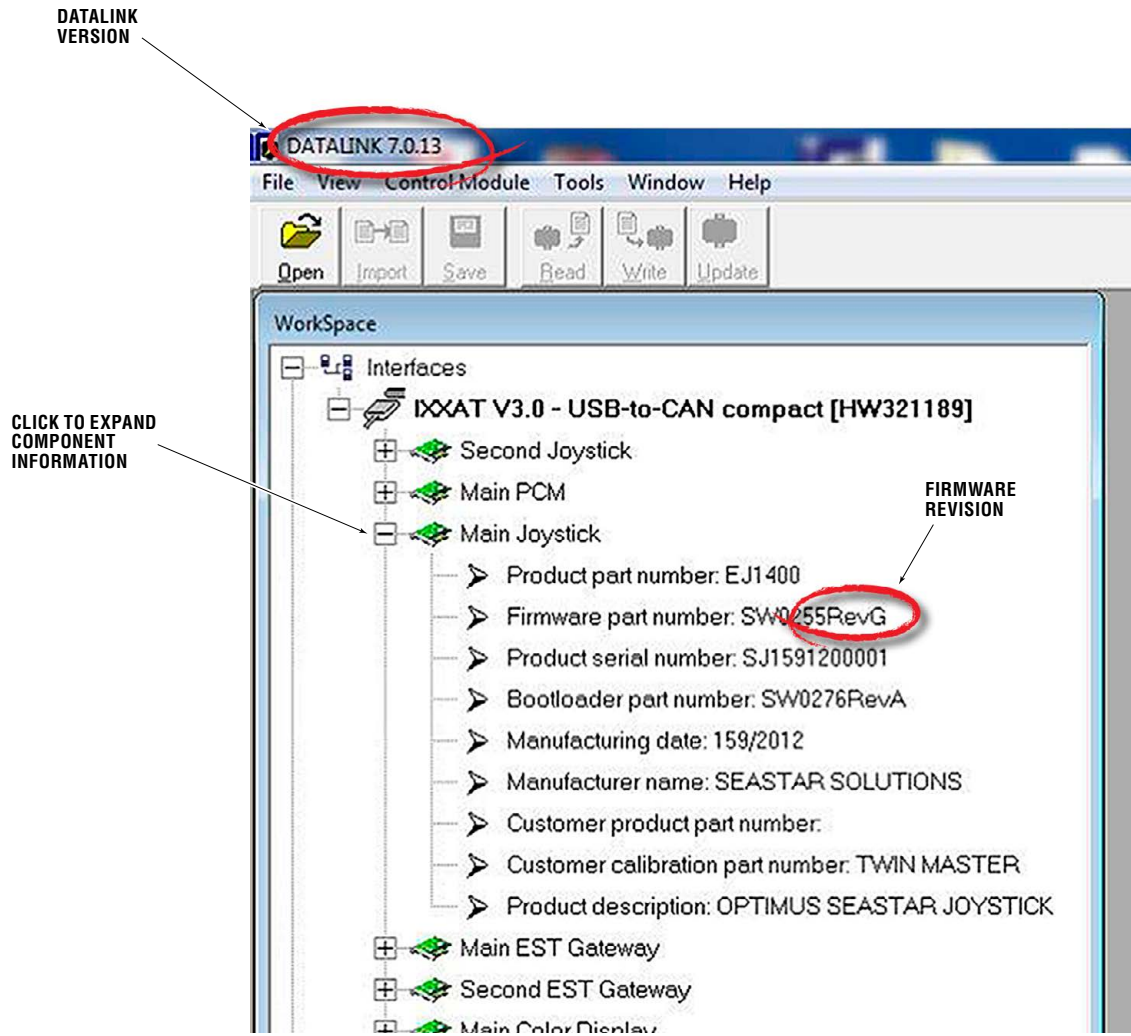

Figure E-6. Datalink Workspace.

## E.4 Backing Up Component Configuration Files

---

It is good practice to make backup copies of component configuration files for every installation. The backups can be used to verify the correct configuration after firmware updates, and to import a configuration to a new component in the event of a failure.

You can back up the configuration files using either the CANtrak display or Datalink. However, it is important to note that the CANtrak reads and writes `.xcu` files, but Datalink reads and writes `.ecu` files. If you export files using the display, they can only be imported using a display. Likewise, files exported with Datalink can only be imported using Datalink.

### E.4.1 Using CANtrak

---

The entire system can be backed up in one step using the CANtrak display and a portable USB drive.

1. Insert a USB drive into the port on the back of the CANtrak display.
2. Navigate to **Dealer Menu > Tools > Export System Settings**.
3. Set USB Drive as the destination and press **Select**.
4. The display will export the `.xcu` configuration file for every device in the system. If necessary, the procedure creates a directory structure on the USB drive and places the `.xcu` files in appropriately named folders.
5. The `.xcu` files are given the name `[device serial number].xcu`. For future use you should give these files meaningful names, that include the component name, revision level, and current date. (You will need to use a computer – you can't do it through the display.) For example:
  - Helm Rev B YYYY-MM-DD.xcu
  - PortShiftActuator Rev A YYYY-MM-DD.xcu

Don't change the names of the folders that were created on the USB drive. The system uses these folder names to locate the `.xcu` files for import later.

### E.4.2 Using Datalink

---

The location of backup files in your computer's folder system is not critical. It is only important that they be well organized and easy to find. We recommend that you create a folder on your desktop named 'Optimus ECU Backups' and create meaningfully named subfolders for each installation project. Regularly copy the contents of the backup folders to another computer (or to an internet service such as DropBox) so that you retain the backups in the event of a computer failure.

#### Procedure

1. Connect to the Optimus system using Datalink as shown in Appendix C.
2. Double click the component name in the Interfaces list to access the component configuration pages.

3. Click **Save** on the toolbar.

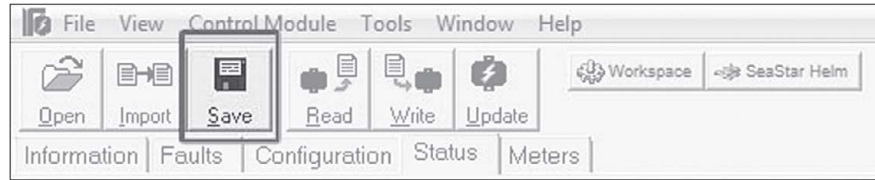

Figure E-7. Click Save to Backup Configuration.

4. Navigate to the desired backup location. Change the file name to include the component name, revision level and the current date. For example:
  - Helm Rev B YYYY-MM-DD.ecu
  - PortShiftActuator Rev A YYYY-MM-DD.ecu
5. Click **Save** to finish.

## E.5 Updating the CANtrak Software

The CANtrak software can only be updated from the display. You will need a USB drive (preferably empty) and a computer to perform the update.

### Procedure

1. If you haven't already done so, download and install the file updater (section E.1).
2. Find the Optimus Firmware folder on your desktop and open it, then open the Color CANtrak folder.
3. In the Color CANtrak folder you will find a .zip file. Double-click on it to view the files in the folder.
4. Copy all the files to the root level of your USB drive. Don't put them in a file folder.
5. Plug the USB drive into the port on the back of the CANtrak. If your system is off, turn it on now.
6. The software update process is automatic. When prompted, remove the USB drive from the display. The display will reboot into the updated software version.
7. Delete the files you copied to the USB drive. If you don't, you won't be able to use the USB drive for other CANtrak functions.

## E.6 Opening a Back-up (ECU) File

### NOTICE

*Opening an ECU file will not import its settings to the system. Opening an ECU file should be used only for reference to verify that configuration parameters were saved correctly after an update. This is only valid for Datalink, as there is no way to do this through the CANtrak.*

1. With the notebook computer connected and Datalink open, click on **Open** on the top toolbar.
2. Navigate to the backup file location (Typically [Desktop\DATALINK Folder\ECU Files]), select the desired backup file and click **Open**.
3. The backup file will open. It can be identified at the top of the Datalink screen by a different name and icon.

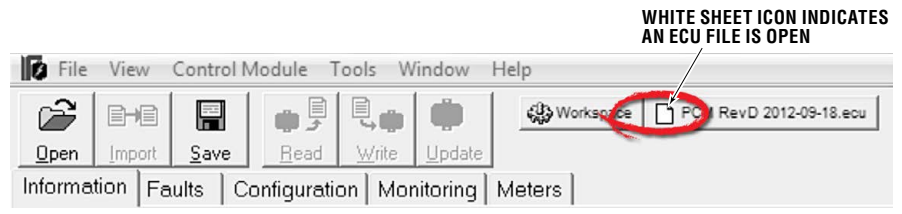

Figure E-8. ECU File Icon.

## E.7 Disabling Automatic Check for Updates

Every time the system is started the color CANtrak will automatically scan all the components and check the software versions. (During the scan the Menu button will not be displayed.) In most systems the scan will not trigger a warning unless a component is replaced. However, there are times when an engineering (non-production) release of software may be used in a system. In this case the automatic scan would cause a warning on every startup, so it should be disabled. Contact technical support for instructions.

*This page left intentionally blank.*

# APPENDIX F BOLT TORQUE SPECIFICATIONS

These are the recommended maximum torque values for reusable dry bolts. Bolts should be torqued to this value +0% - 20%. For lubricated bolts, multiply the dry bolt torque values by 0.75.

Values are stated in: ft/lbs (N.m)								
Bolt Size	18-8SS	Brass	Bolt Size	18-8SS	Brass	Bolt Size	18-8SS	Brass
2-56	2.5 (.282)	2.0 (.226)	6-32	9.6 (1.08)	4.9 (.554)	5/16"-18	132.0 (14.91)	107.0 (12.10)
2-64	3.0 (.338)	2.5 (.282)	6-40	12.0 (1.35)	9.9 (1.12)	5/16"-24	142.0 (16.04)	116.0 (13.11)
3-48	3.9 (.440)	3.2 (.361)	8-32	20.0 (2.25)	16.0 (1.81)	3/8"-16	236.0 (26.66)	192.0 (21.71)
3-56	4.4 (.497)	3.6 (.407)	8-36	22.0 (2.48)	18.0 (2.03)	3/8"-24	259.0 (29.20)	212.0 (23.97)
4-40	5.2 (.587)	4.3 (.486)	10-24	23.0 (2.59)	19.0 (2.14)			
4-48	6.6 (.740)	5.4 (.610)	10-32	32.0 (3.61)	26.0 (2.94)			
5-40	7.7 (.869)	6.3 (.712)	1/4"-20	75.0 (8.47)	62.0 (7.01)			
5-44	9.4 (1.06)	7.7 (.869)	1/4"-28	94.0 (10.6)	77.0 (8.70)			
Values are stated in: ft/lbs (N.m)								
Bolt Size	18-8SS	Brass	Bolt Size	18-8SS	Brass	Bolt Size	18-8SS	Brass
7/16"-14	31.0 (42.00)	26.0 (35.25)	5/8"-11	93.0 (126.09)	76.0 (103.04)	1"-8	287.0 (389.12)	235.0 (318.62)
7/16"-20	33.0 (44.74)	27.0 (36.61)	5/8"-18	104.0 (141.00)	85.0 (115.24)	1"-14	259.0 (351.16)	212.0 (287.43)
1/2"-13	43.0 (58.30)	35.0 (47.45)	3/4"-10	128.0 (173.55)	104.0 (141.00)			
1/2"-20	45.0 (61.01)	37.0 (50.17)	3/4"-16	124.0 (168.12)	102.0 (138.29)			
9/16"-12	57.0 (77.28)	47.0 (63.72)	7/8"-9	194.0 (236.03)	159.0 (215.58)			
9/16"-18	63.0 (85.42)	51.0 (69.15)	7/8"-14	193.0 (261.67)	158.0 (214.22)			

---

---

**Notes**

---

---

---

---

---

---

---

---

---

---

---

---

---

---

---

---

---

---

---

---

---

---

---

---

---

---

---

---

---

---



© 2014 MARINE CANADA ACQUISITION INC.  
DBA SEASTAR SOLUTIONS

PRINTED IN CANADA 04/18

Please scan  
this QR code  
and watch our  
latest **Boating  
Safety** video.



SEASTAR SOLUTIONS  
3831 NO.6 ROAD  
RICHMOND, B.C.  
CANADA V6V 1P6

FAX 604-270-7172

**[www.seastarsolutions.com](http://www.seastarsolutions.com)**

**ISO 10592**



FORM NO. 682100 REV. H

