

MEMBER
ABYC
Setting Standards for Safer Boating

68

SIXTY EIGHT
ISO 9001

OPTIMUS EPS
BY SEASTAR

BAYSTAR™

SEASTAR™

INSTALLATION MANUAL

ELECTRONIC SHIFT & THROTTLE (EST)

www.seastarsolutions.com



i6800 Shift & Throttle System



**SEASTAR
SOLUTIONS®**

*Before you do it your way,
please try it our way*

©2014 SeaStar Solutions.

All Rights Reserved. This document, subject matter and all information herein is the sole, exclusive and confidential property of SeaStar Solutions and shall not be disclosed, copied, reproduced or used in whole or in part for any purpose other than as specifically authorized in writing by Marine Canada Acquisition (DBA SEASTAR SOLUTIONS).

All information, illustrations and specifications in this manual are based on the latest information available at the time of publishing. The illustrations used in this manual are intended as representative reference views only. Moreover, because of our continuous product improvement policy, we may modify information, illustrations and/or specifications to explain and/or exemplify a product, service or maintenance improvement. We reserve the right to make any change at any time without notice.



is a registered trademark of the American Boat & Yacht Council (<http://www.abycinc.org>)

NMEA 2000® is a registered trademark of the National Marine Electronics Association.

Optimus, Optimus 360, SeaStar, and BayStar are all trademarks of SeaStar Solutions.

**California
Proposition 65 Warning**

Battery posts, terminals, and related accessories contain lead and lead compounds, chemicals known to the state of California to cause cancer and reproductive harm.

Wash hands after handling.

Thank you for choosing an i6800 Electronic Shift and Throttle (EST) System. You have chosen a state of the art shift and throttle system that will provide years of effortless and trouble free performance.

About this Book

This book contains the information required to install and setup the i6800 EST System.

It is to be delivered to the customer when installation is complete.

Notice to the Installer

Throughout this publication, Dangers, Warnings and Cautions (accompanied by the International Hazard Symbol ) are used to alert the user to special instructions concerning a particular service or operation that may be hazardous if ignored or performed incorrectly or carelessly. **Observe Them Carefully!**

These safety alerts alone cannot eliminate the hazards that they signal. Strict compliance with these special instructions during installation, operation, and maintenance, plus common sense operation, are important measures to prevent accidents.

DANGER

IMMEDIATE HAZARDS WHICH, IF NOT ACTED UPON, WILL RESULT IN SEVERE PERSONAL INJURY OR DEATH.

WARNING

HAZARDS OR UNSAFE PRACTICES WHICH, IF NOT ACTED UPON, COULD RESULT IN SEVERE PERSONAL INJURY OR DEATH.

CAUTION

Hazards or unsafe practices which COULD result in minor injury or product or property damage.

NOTICE

Information which is important to proper use or maintenance, but is not hazard-related.

This page left intentionally blank.

INDEX

1.0	Safety	1-1
1.1	Safety Labels	1-3
2.0	System Overview.....	2-1
2.1	System Description.....	2-1
2.2	System Overview Diagram	2-2
3.0	Installation	3-1
3.1	Important Information/Technical Support Contact	3-1
3.2	Installing the Control Head	3-1
3.2.1	<i>Control Head Trim Switch Connection</i>	3-1
3.3	Installing the Actuators	3-3
3.3.1	<i>Location, Identification & Mounting</i>	3-3
3.3.2	<i>Start-In-Gear Protection</i>	3-3
3.3.3	<i>Actuator Power Connections</i>	3-4
3.3.4	<i>Actuator Ignition Connections</i>	3-4
3.3.5	<i>Shift Actuator Electrical Connections</i>	3-5
3.3.6	<i>Throttle Actuator Electrical Connections</i>	3-6
3.4	CAN2 Harness Connections.....	3-7
3.5	Engine RPM Source	3-10
3.5.1	<i>NMEA Gateway Connection</i>	3-10
4.0	System Setup	4-1
4.1	Initial Setup.....	4-1
4.2	Actuator Setup	4-4
4.2.1	<i>Step 1 – Actuator Configuration Using the CANtrak Display</i>	4-4
4.2.2	<i>Step 2 – Cable Installation and Adjustment</i>	4-7
4.2.2.1	<i>Shift Cable Installation</i>	4-8
4.2.2.2	<i>Throttle Cable Installation</i>	4-9
4.2.3	<i>Final Setup and Actuator Adjustment</i>	4-10
4.3	Control Head Setup	4-13
5.0	Sea Trial	5-1
5.1	Shift Performance.....	5-1
5.2	Throttle Performance	5-1
5.3	Control Head Adjustments	5-1
5.4	Conclusion of Sea Trial.....	5-2
6.0	System Faults & Hazards.....	6-1
6.1	Hazard Definitions	6-1
6.1.1	<i>Danger</i>	6-1
6.1.2	<i>Warning</i>	6-1
7.0	Warranty	7-1
7.1	Statement of Limited Warranty	7-1

7.2 Return Goods Procedure	7-1
7.3 Technical Support.....	7-1
Appendix A – Mounting Templates	A-1
A.1 Control Head – Dual Lever.....	A-1
A.2 Control Head – Single Lever.....	A-2
Appendix B – Using the Color CANtrak Display	B-1
B.1 Display Navigation	B-1
B.2 Documentation Conventions	B-2
B.3 Initial Startup	B-3
B.4 Unlocking the Dealer Menu.....	B-3
B.5 Menu Structure	B-4
Appendix C – Setup with Datalink	C-1
C.1 Dealer Tools	C-1
C.2 Connection.....	C-1
C.3 Navigating Datalink	C-3
C.4 Actuator Setup	C-5
C.4.1 Step 1 – Actuator Configuration Using Datalink	C-5
C.4.2 Step 2 – Cable Installation and Adjustment	C-7
C.4.3 Step 3 – Final Setup and Actuator Adjustment	C-7
C.5 Control Head Setup	C-9
Appendix D – Updating Firmware	D-1
D.1 Checking Component Firmware Revision Levels.....	D-2
D.1.1 Using DATALINK.....	D-2
D.2 Updating Actuators and Control Head.....	D-3
D.3 Updating the CANtrak Software.....	D-4

1.0 SAFETY INFORMATION

⚠ WARNING

THE SAFETY INFORMATION PROVIDED HERE IS INTENDED TO INFORM YOU OF THE DANGERS THAT MAY BE PRESENT BEFORE, DURING, AND AFTER INSTALLATION. IT IS CRITICAL THAT YOU READ AND UNDERSTAND THIS INFORMATION.

Safe operation of the shift and throttle system depends upon proper installation and maintenance of the system, and the common sense, safe judgment, knowledge, and expertise of the operator. Every installer and operator of the i6800 system should know the following requirements before installing or operating the system. If you have any questions regarding any of these warnings, contact SeaStar Solutions.

Before installation

1. Read and understand all installation and user's manuals provided with the i6800 components.
2. Ensure that all components required to complete the installation are on hand (including cables, harnesses, and the proper tools).
3. SeaStar and i6800 components are highly engineered and safety tested to ensure system integrity. **DO NOT** substitute any component. Substitution with non-SeaStar or non-i6800 components may compromise system safety, performance, and reliability.

During Installation

1. Install system components as directed in this manual. Some component parts and kits may be supplied with additional installation instructions—refer also to these instructions.
2. SeaStar and i6800 components are highly engineered and safety tested to ensure system integrity. **DO NOT** substitute any component. Substitution with non-SeaStar or non-i6800 components may compromise system safety, performance, and reliability.
3. If an instruction is unclear, contradictory, or you are otherwise uncertain how to proceed, do not guess. Call SeaStar Solutions technical support.

After Installation

1. Check that there is no interference between the control head levers and the steering wheel or any other dash-mounted components.
2. Operate the trim/tilt switch on the control head lever and verify that the engines tilt in the expected direction.
3. Check that the mechanical cable bends are smooth and have an appropriate minimum radius.

Prior to every use

Perform a system inspection as outlined below.

1. Check steering fluid level.
2. Verify immediate steering response when turning steering wheel(s).
3. Inspect all steering hoses, fittings, mechanical cables, and electrical harnesses for wear, kinks, or leaks.
4. Check for binding, loose, worn or leaking steering or shift/throttle control components.
5. Verify proper shift and throttle response for all control handles.

⚠ WARNING

DO NOT OPERATE BOAT IF ANY COMPONENT IS NOT IN PROPER WORKING CONDITION.

During use

1. WEAR A COAST GUARD-APPROVED PERSONAL FLOTATION DEVICE (PFD).
2. ATTACH ENGINE SHUT-OFF CORD (LANYARD) TO YOUR PFD.
3. Never allow anyone who is not familiar with the operation of the shift and throttle system to operate the boat at any time.
4. If boat is equipped with multiple helms, ensure that only one is used at a time.
5. Know and adhere to all applicable federal, state, and municipal laws and regulations that govern boating in your area.

⚠ WARNING

DO NOT OPERATE BOAT IF ANY COMPONENT IS NOT IN PROPER WORKING CONDITION.

After use

The i6800 system requires no special attention after use. Periodically clean the control head with a damp cloth or mild soap. DO NOT use acetone, or cleaners containing ammonia, acids, or any other corrosive ingredients.

⚠ WARNING

FAILURE TO COMPLY WITH ANY WARNING, NOTICE OR CAUTION MAY LEAD TO LOSS OF STEERING OR SHIFT/THROTTLE CONTROL RESULTING IN A COLLISION AND/OR EJECTION FROM THE BOAT LEADING TO PROPERTY DAMAGE, PERSONAL INJURY AND/OR DEATH.

1.1 Safety Labels

⚠ WARNING

THE LABELS BELOW SHOULD CALL ATTENTION TO THE POSSIBLE HAZARDS ASSOCIATED WITH THE EQUIPMENT SHOWN LATER IN THIS MANUAL.

Component labels

The labels shown below are found on the i6800 actuators.



Figure 1-1. Start-In-Gear Advisory Decal, PID# 682050.

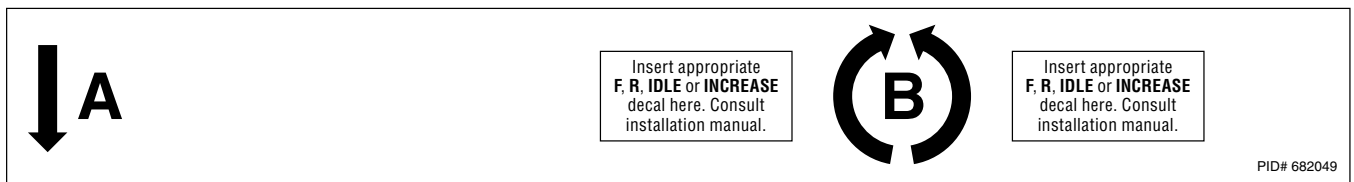

Figure 1-2. A and B Locator Decal, PID# 682049.

Affix PORT/STARBOARD decal here, consult installation manual.	<h1>ACTUATOR</h1>	Affix SHIFT/THROTTLE decal here, consult installation manual.
<p>MANUAL OVERRIDE OPERATION</p> <ol style="list-style-type: none"> 1. MOVE ALL LEVERS A IN THE DIRECTION OF ARROW TO DISENGAGE DRIVE MECHANISM. 2. ROTATE "SHIFT" LEVER B CLOCKWISE, OR COUNTER-CLOCKWISE TO MOVE CONTROL CABLE INTO DESIRED GEAR. 3. CONFIRM YOUR DESIRED GEAR IS ENGAGED BEFORE APPLYING THROTTLE. 4. VERY SLOWLY ROTATE LEVER B ON THROTTLE ACTUATOR TO "INCREASE" RPM. NO MORE THAN 1/2 TURN SHOULD BE REQUIRED. 5. KEY OFF IGNITION TO SLOW AND STOP VESSEL. 		<div style="border: 1px solid black; padding: 5px;"> <p>⚠ WARNING</p> <p>USING THE ACTUATOR OVERRIDE SYSTEM MAY SEVERELY LIMIT YOUR BOATS CONTROL. IT SHOULD ONLY BE USED IN AN EMERGENCY IF YOU ARE UNABLE TO CALL FOR ASSISTANCE. ALWAYS TRY ALTERNATIVE CONTROLLING DEVICES. PROCEED WITH EXTREME CAUTION, READ USER'S MANUAL, ALWAYS WEAR A PFD & LANYARD.</p> </div> <div style="border: 1px solid black; padding: 5px; margin-top: 5px;"> <p>⚠ WARNING</p> <p>U.S. COAST GUARD REQUIRES START-IN-GEAR PROTECTION. IF YOUR ENGINE DOES NOT HAVE THIS FEATURE, THIS CONTROL SYSTEM WILL PROVIDE START-IN-GEAR PROTECTION MEETING U.S.C.G. REQUIREMENTS OF 33 CFR PART 183, SUB PART L. CONSULT INSTALLATION MANUAL.</p> </div>

Figure 1-3. Actuator decal, PID# 682048.

This page left intentionally blank.

2.0 SYSTEM OVERVIEW

2.1 System Description

SeaStar i6800 is an electromechanical system that replaces a traditional cable-operated engine remote control with an electronic control. Shift and throttle settings are sent over a serial data network to electro-mechanical actuators, where they are converted to cable motion. The elimination of mechanical cables to the control head simplifies multi-station installations, especially when a station is installed onto a flybridge or tower that is removed for shipping. The system supports the installation of up to three control heads.

The i6800 system consists of the major components listed below.

CAN Network

CAN (controller area network) is a serial network protocol that is widely used in marine and automotive control systems. Each device (node) on the network can send and receive data using specially formatted messages. The ability to reliably communicate data between devices is what enables the functionality of i6800.

i6800 implements the high-speed CAN protocol using DeviceNet harnesses and connectors. We refer to the network as CAN2 in the documentation to distinguish it from other CAN protocols used on SeaStar products.

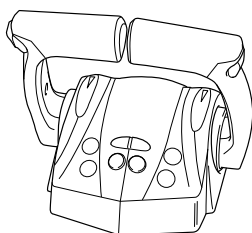

Control Head

The control head looks much like a conventional mechanical remote control, but it is an electromechanical device that converts lever position into digital messages that are sent over CAN2 to the shift and throttle actuators. The control head features adjustable lever feel, status lights, a synchronous trim switch (optional), and control buttons for added functionality.

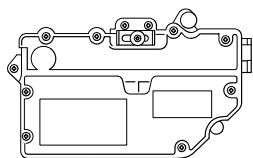

Shift and Throttle Actuators

The actuators are electromechanical devices that receive digital commands on the CAN2 network and convert these commands into movement of a mechanical cable for gear selection and throttle control. The actuators are universal, and are easily setup for their specific application using the CANtrak display tool. They can also provide the start-in-gear protection required by the U.S. Coast Guard.

2.2 System Overview Diagram

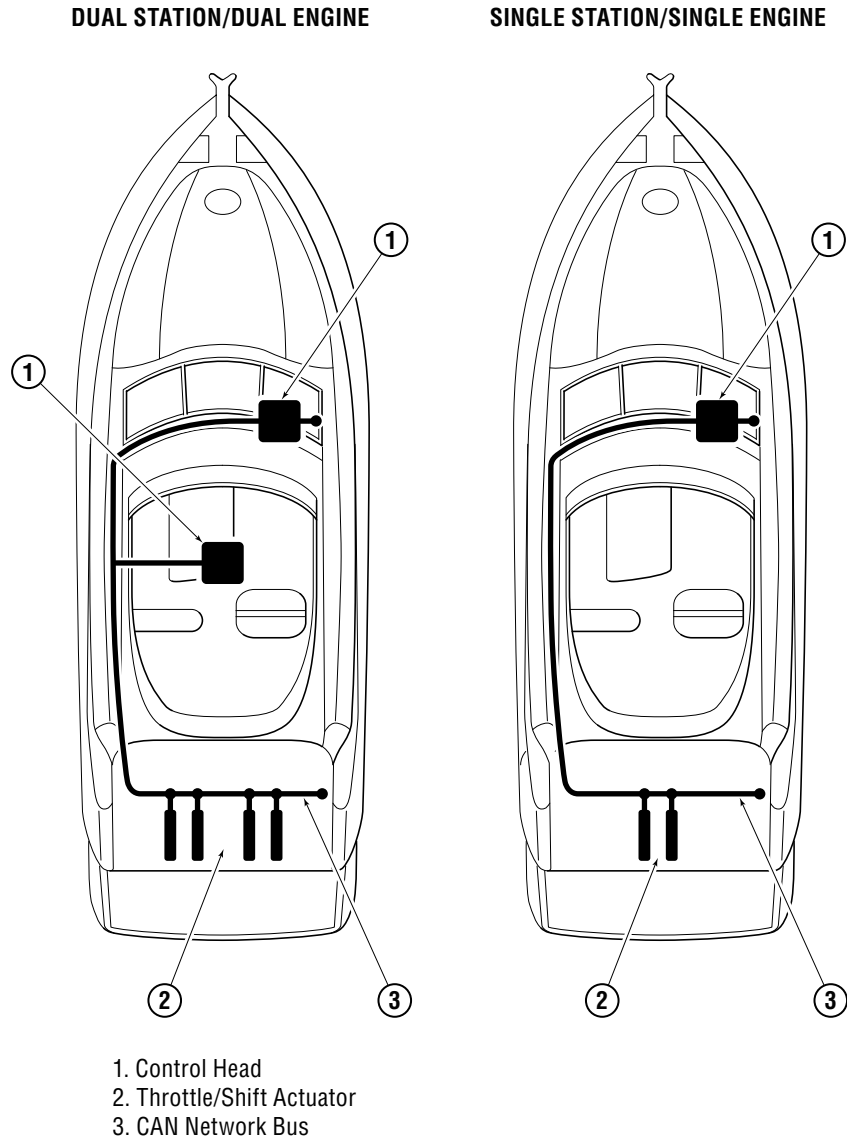

Figure 2-1. System Overview.

3.0 INSTALLATION

3.1 Important Information/Technical Support Contact

To assist with the installation and maintenance of this Electronic Shift and Throttle system SeaStar Solutions recommends that:

- Installation **MUST** be performed by a SeaStar Solutions authorized installer.
- Read and understand ALL installation manuals before starting the installation process. Knowing the correct order of installation and location of components will drastically reduce installation time as well as prevent common installation errors.
- Read and understand ALL Safety Information that is noted in this manual and ALL other Installation Manuals.

If any problems are found before, during or after the installation of the steering system, please contact Technical Support for assistance:

Technical Support

Web: www.seastarsolutions.com

E-mail: seastar@seastarsolutions.com

Phone: 604.248.3858

Fax: 604.279.2202

3.2 Installing the Control Head

Mount the control head on the dash in an area which will allow for convenient access during use. Whenever possible, it should be mounted in a location to minimize water spray. Ensure that the control handle(s) can be moved throughout the complete range of motion in both forward and reverse without interference. ABYC standard P-14 calls for a minimum of 2 1/2" (64 mm) clearance between the control lever and the steering wheel rim under all possible lever and wheel positions.

The control head requires one of the dash cutout templates in Appendix A.

3.2.1 Control Head Trim Switch Connection (Optional)

The control head includes a single trim/tilt switch on the end of the port handle. This switch can be wired to provide synchronous trim/tilt control of all engines. If independent trim/tilt is desired use tilt/trim kit HA5491 (for twin engine configurations) and connect the wiring as shown in Figure 3-1.

⚠ WARNING

ALL ELECTRICAL CONNECTIONS AND HARNESS MUST COMPLY WITH ABYC WIRING STANDARDS, BE RATED FOR 105°C (221°F), AND COMPLIANT WITH SAEJ1128.

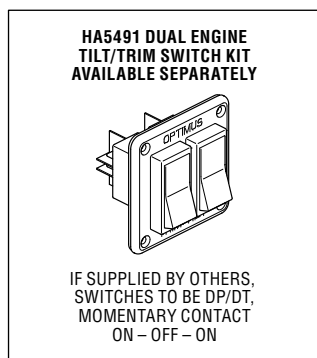

WIRE COLOR LEGEND

TRIM UP	BLUE	=====
TRIM DOWN	GREEN	=====
POWER	RED	=====

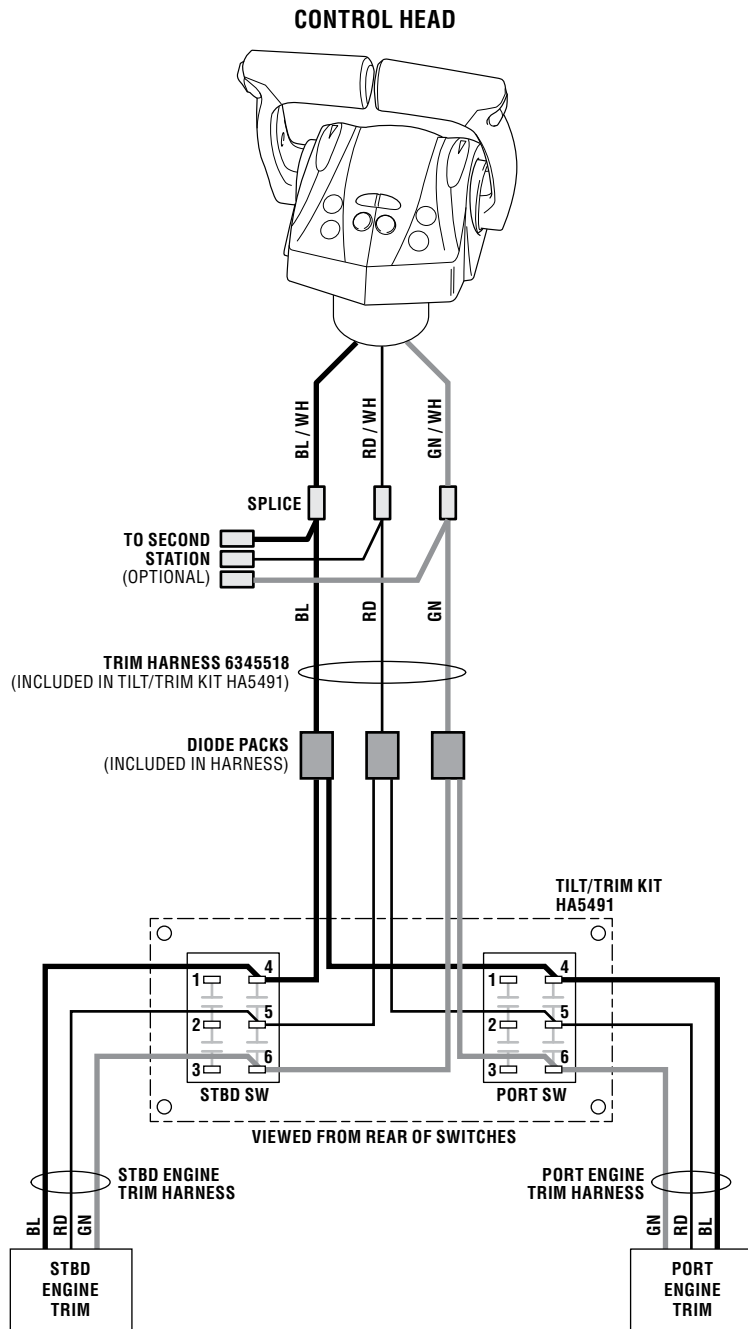

Figure 3-1. Trim switch wiring.

3.3 Installing the Actuators

3.3.1 Location, Identification & Mounting

- Actuators should be mounted to allow for the shortest, straightest, most direct mechanical cable run. Check the information included with your cables and note the minimum bend radius.
- Actuators should be mounted in as dry of a location as possible.
- The actuators will require power and network connections and may require start-in-gear protection wiring connections.
- Shift and Throttle cables require adequate clearance where they exit the actuators and enter the engines and should avoid tight bends.
- Actuators should be mounted where they can be accessed for manual operation if required and where manual override instruction decals are clearly visible.

All actuators are configured identically from the factory so they can be used interchangeably during installation. Once an actuator's function has been decided, apply labels from the label sheet provided to identify its type (shift vs. throttle) and side (port vs. starboard, if applicable), then record the serial numbers in Table 3-1 below. (See figure 4-11 for location of serial number.) These serial numbers will be used when the actuators are configured electronically in Section 4.2.

Actuator	Serial Number
Port Shift	
Port Throttle	
Starboard Shift	
Starboard Throttle	

Table 3-1. Actuator serial numbers.

The label sheet also contains labels to identify the correct override knob direction. These will be applied when the actuators are configured in Section 4.2.

There are two ways to mount the actuators:

1. Three bolts (M8 x 1.25 x 440 mm) can be used for rear mount applications (Bolt heads behind the mounting panel).
2. Three screws and washers can be used for front mount applications (#12 MAX).

NOTICE

You may rough in the mechanical cables but do not connect them to the actuators at this point.

3.3.2 Start-In-Gear Protection

The US Coast Guard requires start-in-gear protection. If your engine does not have this feature, this control system will provide start-in-gear protection meeting U.S.C.G requirements of 33CFR part 183, sub part L.

The shift actuators contain a switch that is continuous electrically when the actuator is in neutral position and open circuit when in gear position. This switch may be used to interrupt the ignition start wire to the engine as start-in-gear protection if required. See Section 3.3.5 for actuator wire identification.

3.3.3 Actuator Power Connections

The shift and throttle actuators for each engine are paired together and connected with a shared CE20425 power harness. Each CE20425 harness includes two 4-pin power connections, one for shift and one for the throttle. It is not important which connector is connected to the shift actuator and which is connected to the throttle. Refer to Figure 3-4.

WARNING

PROPERLY SECURE ALL HARNESSSES ON BOTH SIDES OF HARNESS CONNECTORS AND SPLICES. IMPROPER STRAIN RELIEF CAN RESULT IN MECHANICAL FAILURE OF THE CONNECTION OR, IN SOME CASES, THE WATERTIGHTNESS OF THE CONNECTOR. LOCATE ALL SPLICES AND CONNECTORS IN DRY AREAS.

1. Connect the 4-pin connectors to the mating connector on the shift and throttle actuators.
2. Connect the black and green wires to ground.
3. Connect the red wire through a 25 amp circuit breaker to a positive power source; preferably direct to the vessel's batteries or to a battery switch.

3.3.4 Actuator Ignition Connections

The actuator power harness CE20425 has a single white ignition sensing (and CAN power) wire which must be connected to an ignition source that is live when the corresponding engine is in the on position. The white wire delivers the “wake” signal to each pair of actuators and they will not function without the wire connected. As such the integrity of the connection is critical to the safe operation of the system. Please note the following:

- Whenever possible, make your splice connections in dry areas of the vessel. If you must splice in a potentially wet area, always secure the wires in a way that keeps the splice out of pooling water.
- Use sealed, heat-shrink butt splices, such as Molex Perma-Seal, or a soldered connection with heat-shrink tubing. Always follow the manufacturer's installation instructions.
- Secure the wiring on both sides of the splice so that there is no strain on the splice connection.
- Choose a route for the wires that minimizes exposure to water, high temperatures, and mechanical damage.

On most vessels you will have one of two options for an ignition source: a single ignition source wire, or you will have to splice into an existing ignition wire.

Option 1 – single ignition source

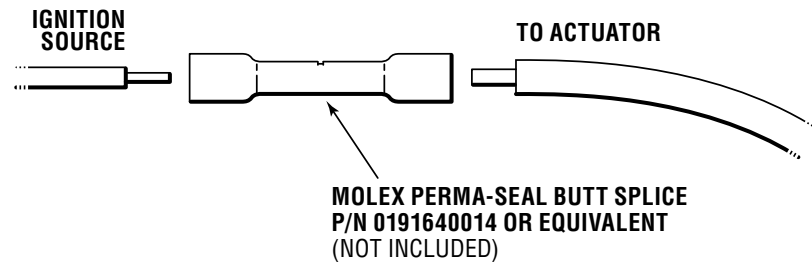

Figure 3-2.

Option 2 – splice into an existing engine ignition wire

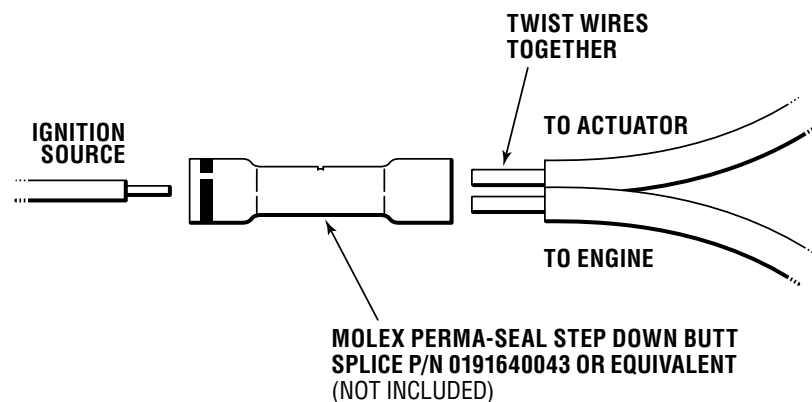

Figure 3-3.

3.3.5 Shift Actuator Electrical Connections

1. To use the start-in-gear protection built into the actuator, intercept the start wire between the ignition switch and the engine start solenoid and connect the actuator switch leads as follows:

Yellow: Connect to ignition switch

Yellow w/red tracer: Connect to engine start solenoid

The following table lists the ignition start system wire colors typically used by each manufacturer. This table serves as a guide only, always consult manufacturer's documentation for correct wire identification.

Manufacturer	Wire Colors
Yamaha	Start circuit – brown
Suzuki	Short the brown wires together
Evinrude	Start circuit – yellow/red
Mercury	Start circuit – yellow/red

Table 3-2. Start-in-Gear wire colors.

NOTICE

The polarity of the start-in-gear protection wires is important. Make the connections as described – do not reverse the wires.

2. If not using start-in-gear protection, cap and tie back the two yellow wires.
3. Connect the round DeviceNet connector to the CAN2 network as shown in Section 3.4.
4. Repeat steps 1-3 for other shift actuator.

3.3.6 Throttle Actuator Electrical Connections

1. Cap and tie back the two yellow wires; these are unused for throttle actuators.
2. Connect the round DeviceNet connector to the CAN2 network as shown in Section 3.4.
3. Repeat steps 1 & 2 for other throttle actuator.

RED AND BLACK ARE ACTUATOR POWER
WHITE AND GREEN ARE CAN POWER

**Older CE20425 used Orange and Brown for CAN Power.*

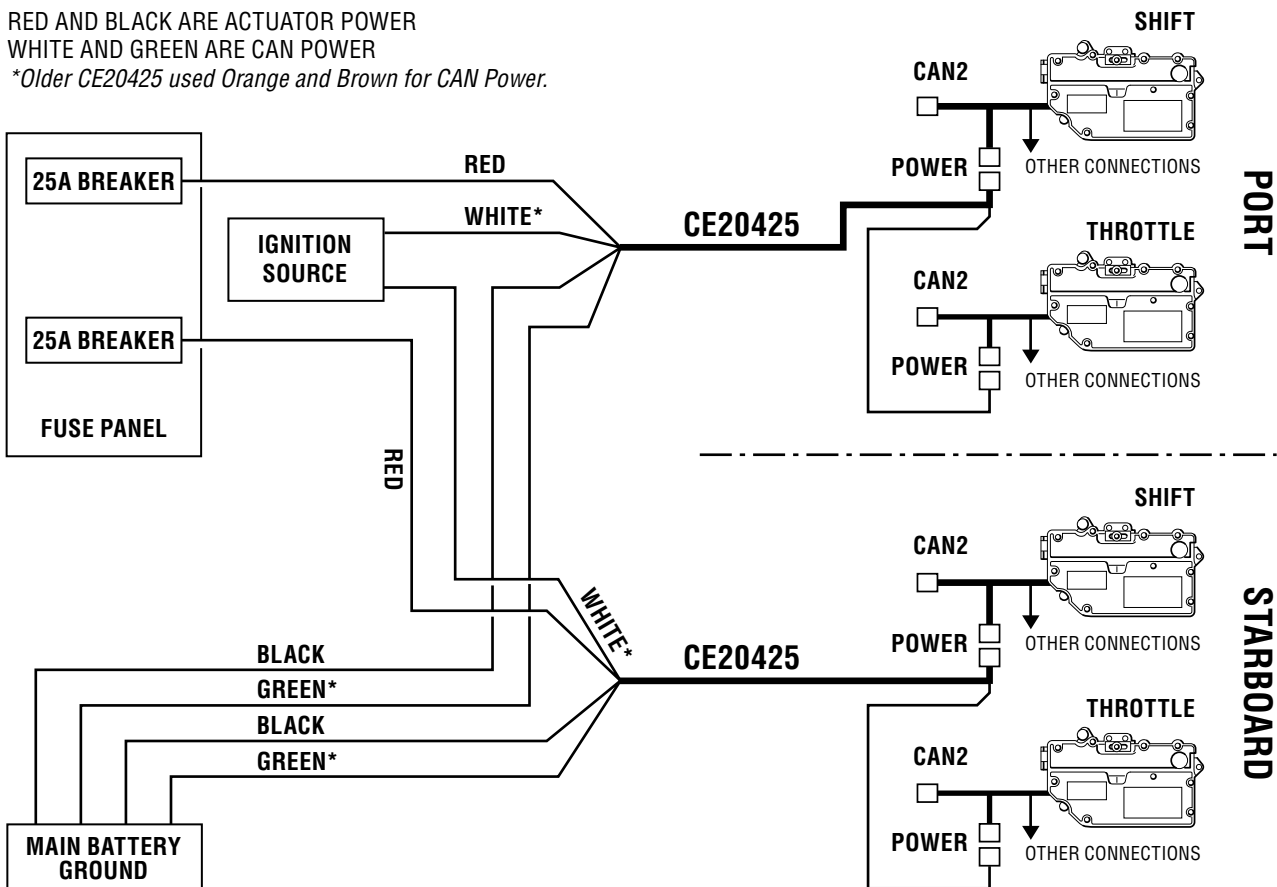

Figure 3-4. CE20425 power harness connection.

3.4 CAN2 Harness Connections

Figure 3-5 and figure 3-6 show the CAN2 network wiring for single and dual station applications. All tees *must* be secured using both screw holes, and the cable drops at each tee must be appropriately secured and strain-relieved to prevent any pull on the tees. See figure 3-7 for proper tee installation example.

The CAN2 network must contain two, and only two, terminating resistors. One terminator should be installed at each end of the network backbone.

⚠ WARNING

FAILURE TO SECURE HARNESS MAY RESULT IN HARNESS WEAR, CAUSING LOSS OF THROTTLE CONTROL, PROPERTY DAMAGE, PERSONAL INJURY AND/OR DEATH.

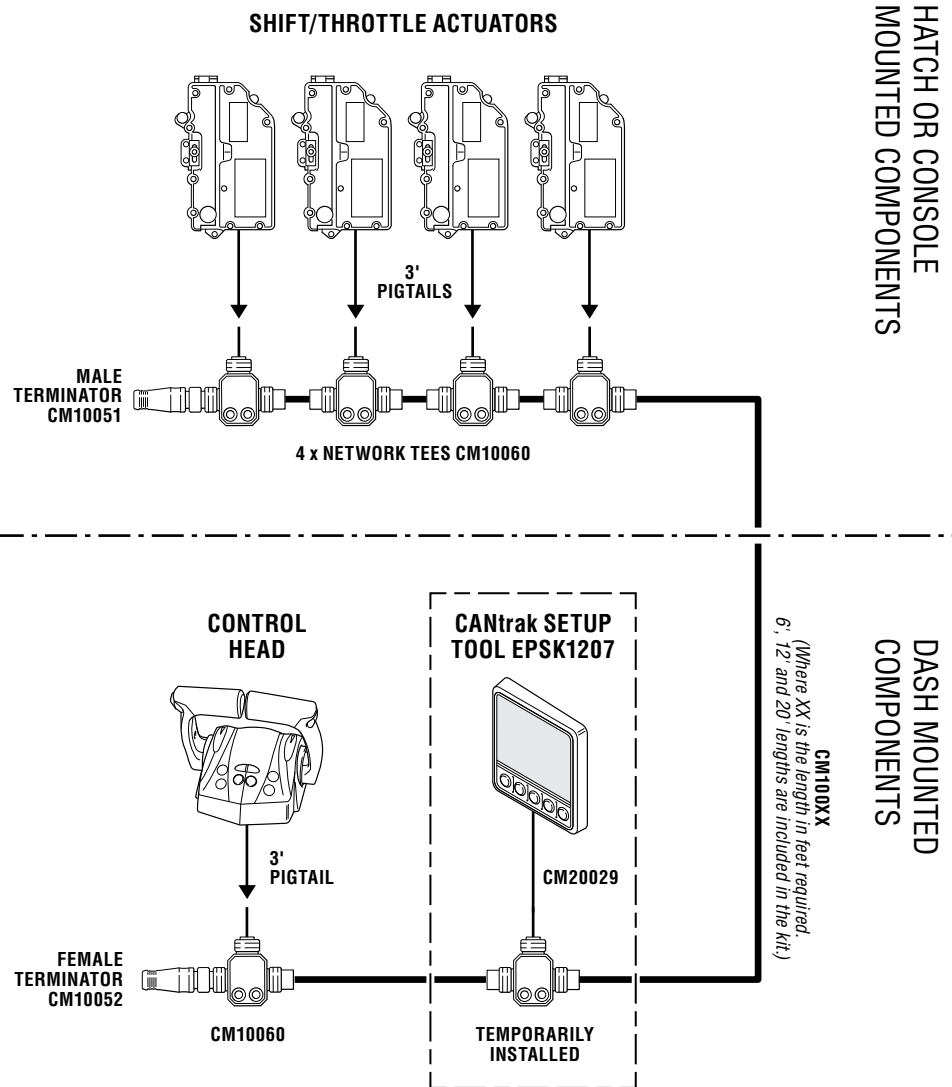
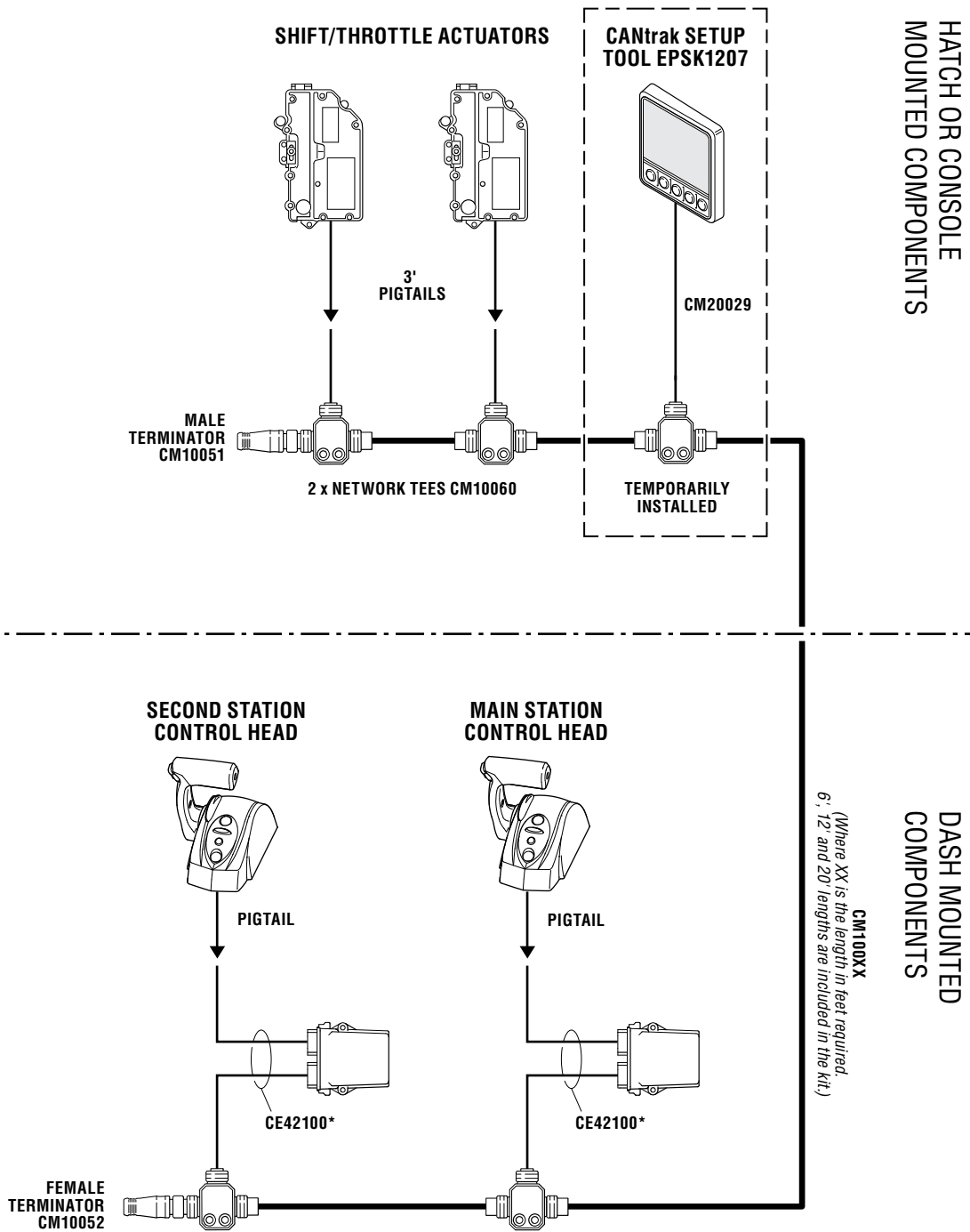

Figure 3-5. CAN2 wiring diagram, single station, twin engine.



* The CE42100 harness contains three flying leads with female bullet connectors. These leads are not used in the i6800 system and should be left unconnected.

Figure 3-6. CAN2 wiring diagram, dual station, single engine.

⚠ WARNING

FAILURE TO SECURE HARNESS MAY RESULT IN HARNESS WEAR, CAUSING LOSS OF THROTTLE CONTROL, PROPERTY DAMAGE, PERSONAL INJURY AND/OR DEATH.

TIP: Once you've tightened the nuts on the tees, mark them with a permanent marker as shown in figure 3-7. This makes it easy to inspect them for tightness later.

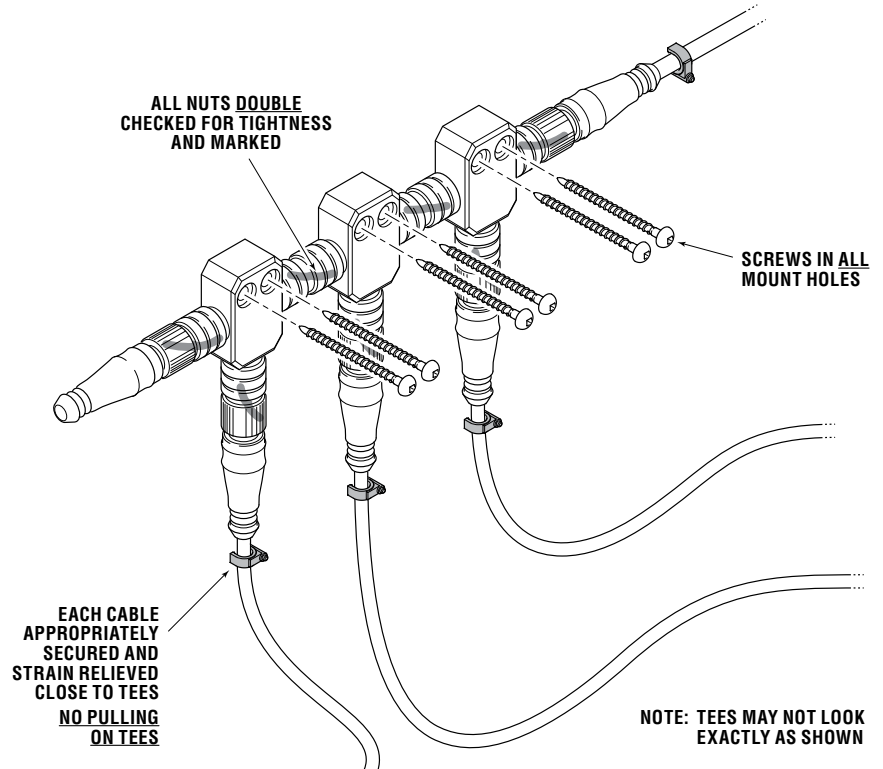

Figure 3-7. Correct CAN2 tee installation example.

⚠ CAUTION

Do not connect anything other than SeaStar components to the CAN2 network.

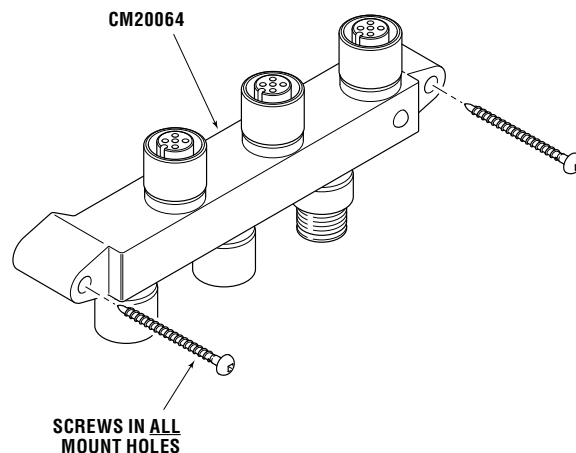

Figure 3-8. Alternative CAN2 6-port hub connection (available separately).

3.5 Engine RPM Source

The i6800 system is designed to work without engine speed feedback. The Power Train Sync (PTS) features described in the User's Manual simply output the same throttle percentage to each engine in order to synchronize engine speeds. In some cases this open loop control technique may result in poor synchronization performance. These performance issues may be corrected by adding engine RPM feedback.

Before adding an RPM source, please consider the following:

- We recommend that you sea trial the vessel and evaluate Sync performance before adding engine RPM feedback.
- The Sync features are intended for use at normal cruising speeds. Poor or marginal Sync performance at low speeds may not justify the added expense of RPM feedback. Always evaluate the performance in the range of normal cruising speeds.
- An engine speed mismatch can often be corrected without an RPM source by carefully adjusting either the throttle actuator adjuster barrels or the Idle Offset parameters. See section 4.2.3.

3.5.1 NMEA Gateway Connection

At the time of printing, the only supported means of obtaining an engine RPM source is with a dedicated NMEA 2000 gateway, available from the engine manufacturer. Do not use an existing gateway connected to an existing NMEA 2000 network. The CAN2 network is not NMEA 2000 compliant, and there is a risk that an otherwise minor failure on the NMEA 2000 bus could interfere with the EST operation.

Connect the NMEA 2000 gateway to the engine bus and to a tee on the CAN2 network as shown in figure 3-9.

⚠ WARNING

ALTHOUGH BOTH NETWORKS USE COMPATIBLE CONNECTORS, DO NOT CONNECT THE I6800 NETWORK TO A PUBLIC NMEA 2000 BUS.

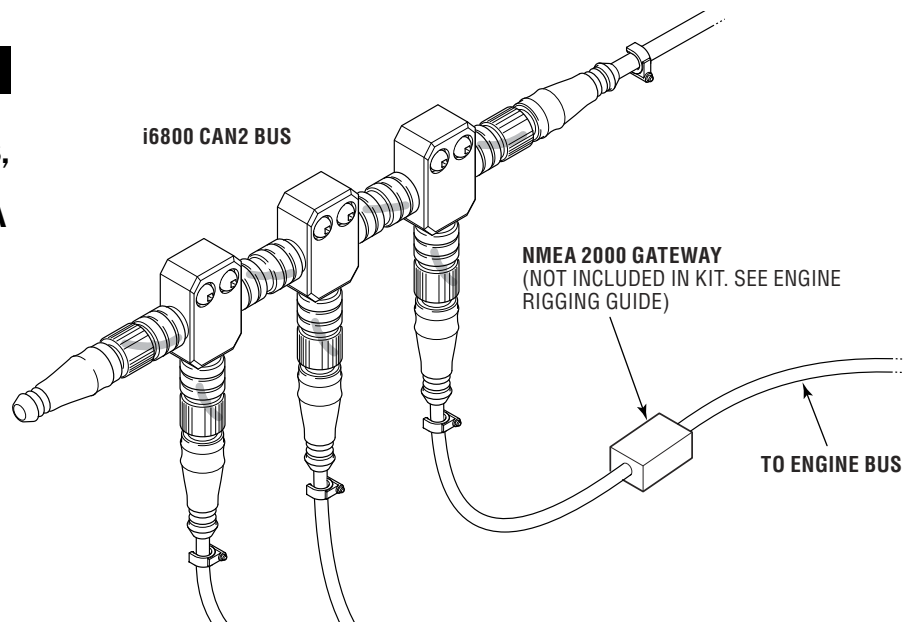

Figure 3-9. NMEA gateway connection.

4.0 SYSTEM SETUP

Before you proceed you need to have all i6800 components installed, harnesses connected, and power wiring completed. The actuator cables should *not* be connected yet.

This section will describe the system setup using the color CANtrak display as a setup tool (P/N EPSK1207). If you prefer to use Datalink you can find instructions in Appendix C.

4.1 Initial Setup

The system setup is performed easily with the color CANtrak display. It is designed to walk you through the following tasks:

- Configure the system type
- Choose the number of devices in your system
- Update system software
- Select device locations

NOTICE

The CANtrak display is used only as a setup tool, and is not intended to be installed on the vessel.

You will need access to the CANtrak Dealer Menu for all setup tasks. See Appendix B for instructions on how to navigate the CANtrak display and access the Dealer Menu.

Procedure:

1. On the display, navigate to **Dealer Menu > Initial Setup > System** to access the System Setup menu.

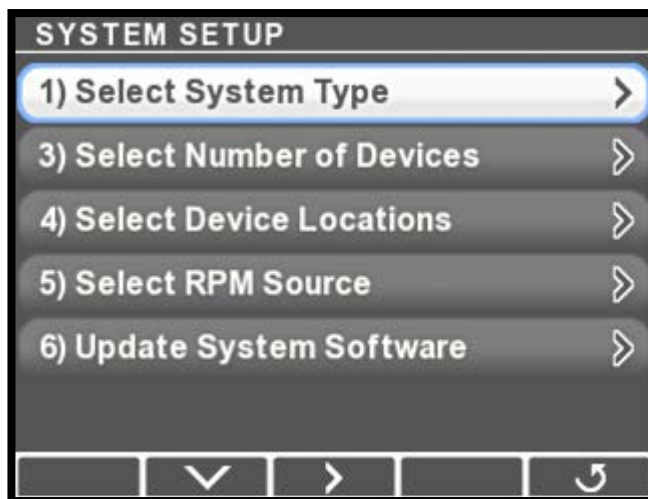

Figure 4-1.

2. Press > to enter the System Type menu.

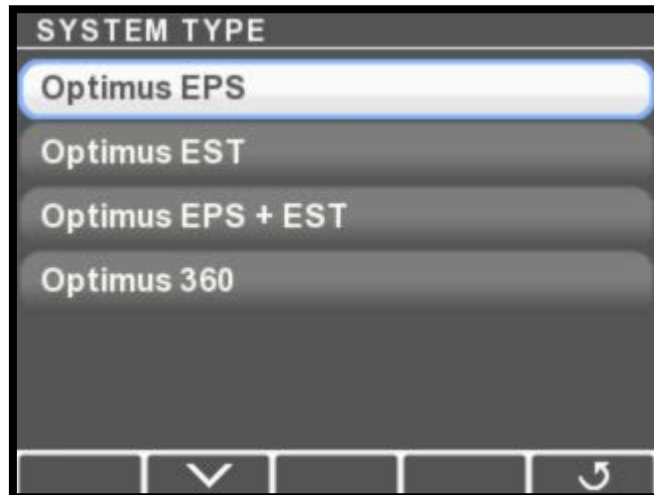

Figure 4-2.

3. Use the down arrow button to select **Optimus EST**, then press **Save**. Press **J** to return to the System Setup menu. You'll see that the menu now has an item called **Select Shift & Throttle Type**. Highlight it and press >.

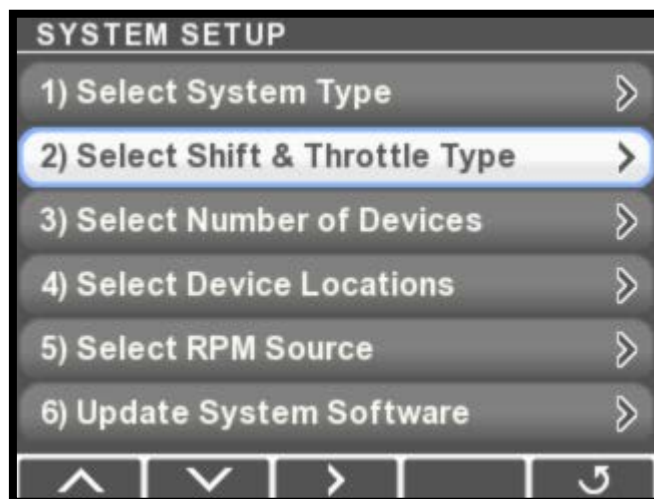

Figure 4-3.

4. Verify that **SeaStar i6800** is highlighted and press Save. Press **↵** to return to the System Setup menu.



Figure 4-4.

5. Choose **Select Number of Devices** and press **>**.

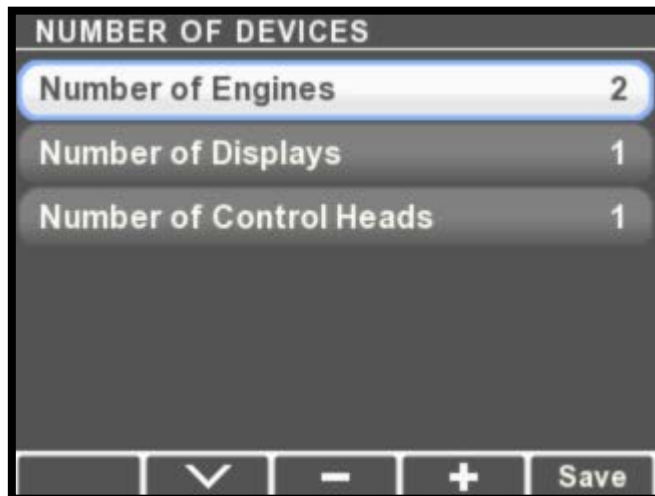

Figure 4-5.

6. Use the **+** and **-** buttons to change the quantity of each device to match your system. Unless you are permanently installing the CANtrak display, set the **Number of Displays** parameter to **0**.

4.2 Actuator Setup

4.2.1 STEP 1 – Actuator Configuration Using the CANtrak Display

The default configuration type for all actuators is Port Shift. Before installing the cables and adjusting the actuator parameters you must configure each actuator to the correct type.

⚠ CAUTION

Ensure mechanical cables are not connected to the actuators at this point.

Procedure:

1. On the CANtrak display, navigate to **Dealer Menu > Initial Setup > System > Select Device Locations**.
2. Find the actuators in the list of devices, and match their serial numbers with the serial numbers you recorded in section 3.3.1. You now know the type (shift or throttle) and the instance (port or starboard) of each actuator.
3. Use the + and – buttons to change each actuator’s configuration to match the type and instance. Make sure that you have one of each type of actuator configured. In a single-engine application set the instance for both actuators to Port.
4. Press **Save** when finished, then ↻ repeatedly to exit. You will be prompted to cycle system power to save the changes.
5. Navigate to **Dealer Menu > Initial Setup > Shift & Throttle** to get to the Shift & Throttle Setup menu.

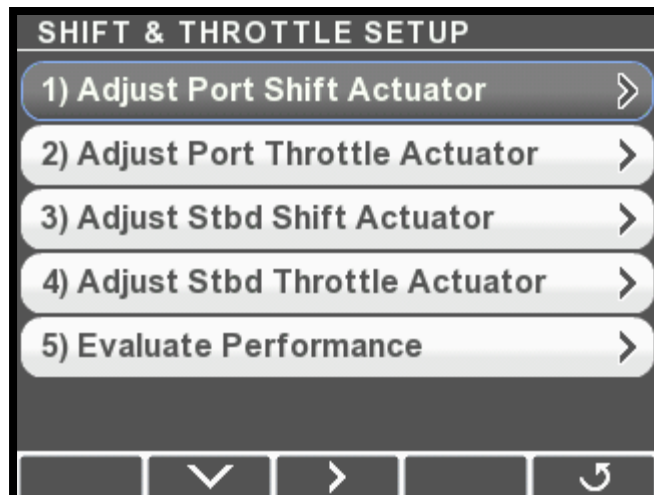

Figure 4-6.

6. For the shift actuator(s), set the Shift to Forward Direction parameter to Push or Pull (see figure 4-7) to match the direction the actuator is required to move to engage *forward* gear. Don't adjust the other parameters yet.

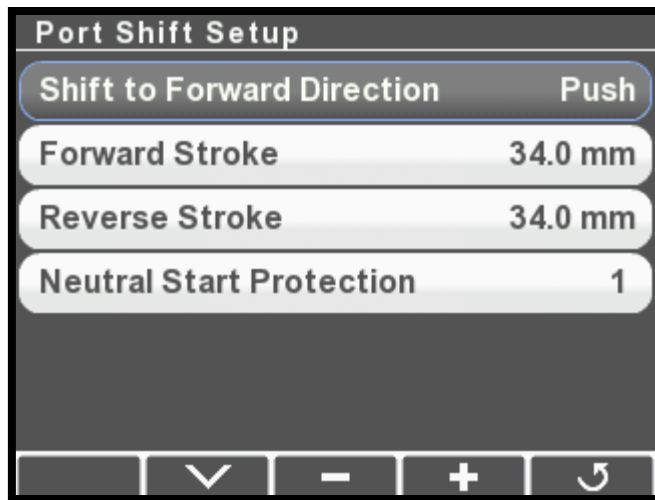

Figure 4-7.

7. For the throttle actuator(s), set the Acceleration Direction parameter to Push or Pull to match the direction the actuator is required to move to *increase* throttle. Don't adjust the other parameters yet.

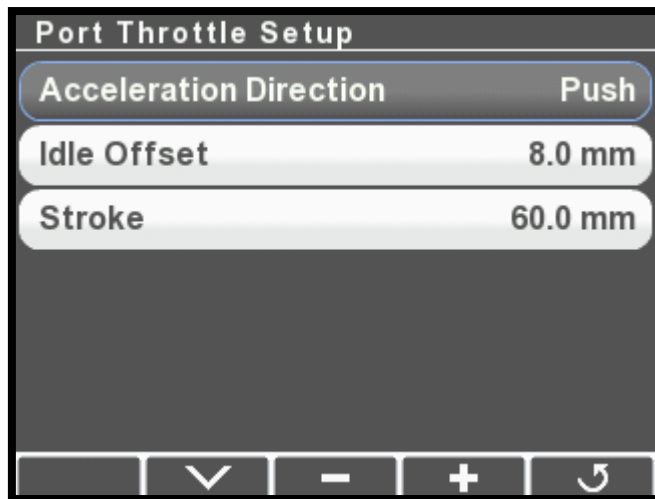

Figure 4-8.

8. Remove the cable access covers (see figure 4-11) on all actuators. Do not connect the mechanical cables yet.

⚠ CAUTION

The actuator contains moving parts and pinch hazards. Keep away from the exposed parts while the cover is removed.

9. With the covers removed, move the port and starboard control head levers to the forward and reverse gear positions and verify that the shift actuator racks move accordingly.

10. Increase the throttle on each of the control head handles from idle to full throttle and check that the throttle actuator racks advance and return accordingly.
11. Apply the correct manual override decals (see figure 4-9 and figure 4-10) to the cable access covers.
12. Press **J** repeatedly to exit. You will be prompted to cycle system power to save the changes.

For **PUSH** to Throttle Acceleration

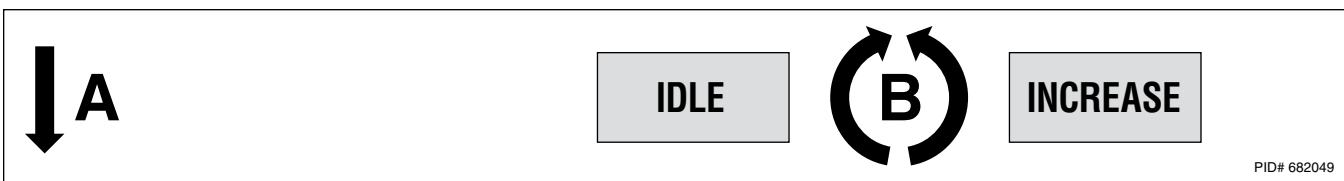

For **PULL** to Throttle Acceleration

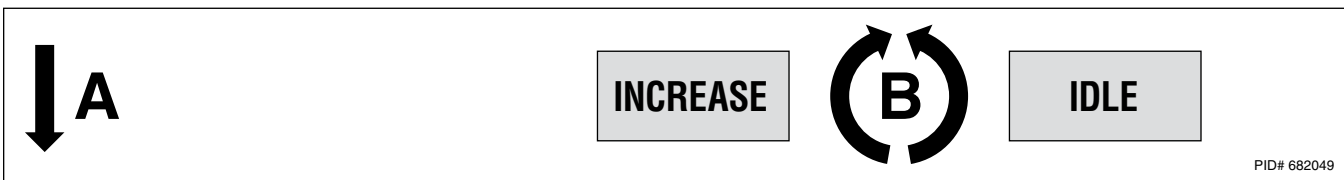
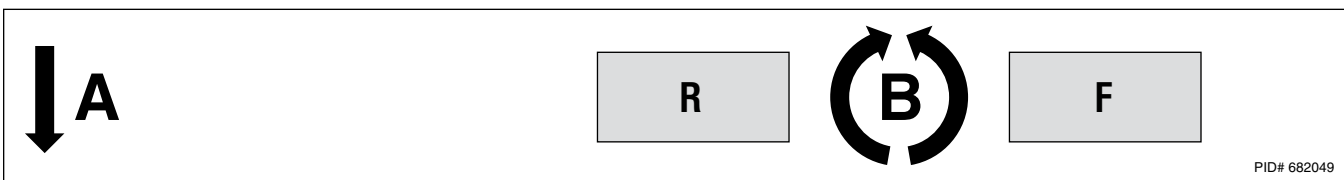

Figure 4-9. Throttle actuator manual override decal placement.

For **PUSH** to Shift to Forward



For **PULL** to Shift to Forward

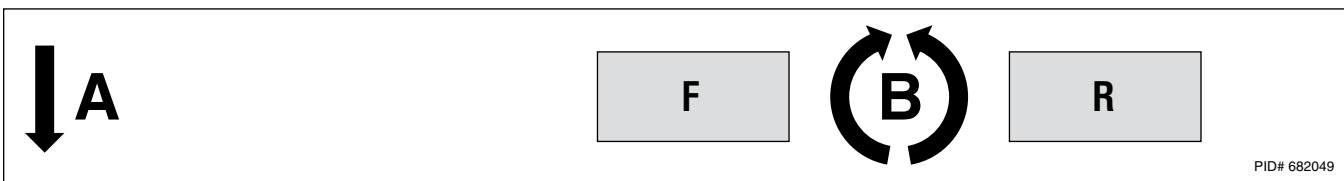

Figure 4-10. Shift actuator manual override decal placement.

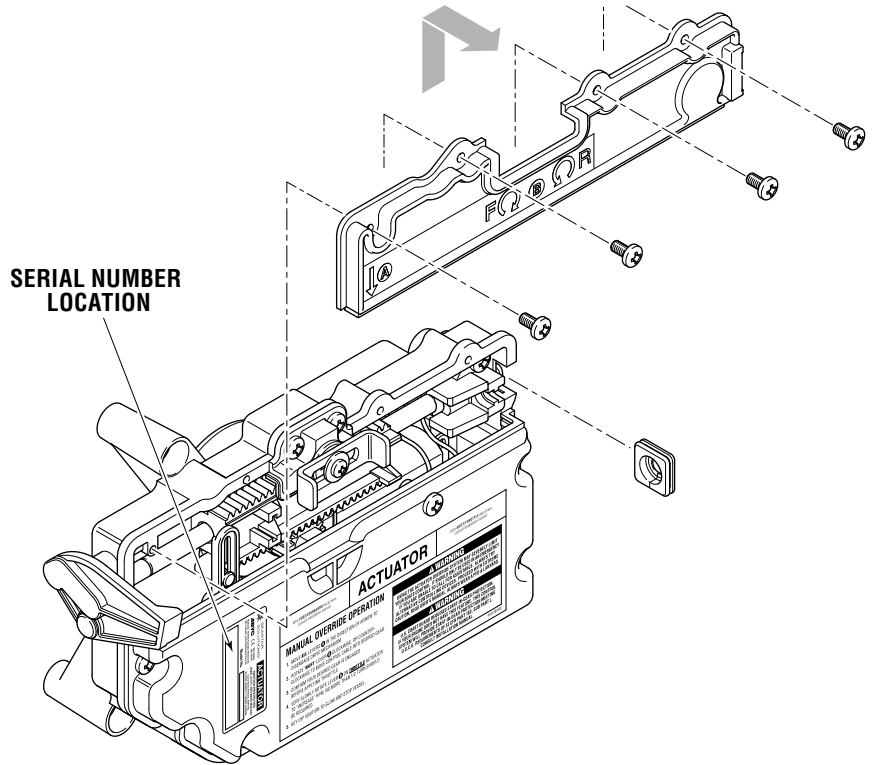

Figure 4-11. Actuator cover removal and location of serial number.

4.2.2 Step 2 – Cable Installation and Adjustment

Proper cable adjustment is critical for overall system performance. This section will describe how to install and adjust the shift and throttle cables. Be sure to review and understand the installation goals for each section before proceeding.

NOTICE

Take into consideration when installing mechanical cables that you may not be able to shift outboard engines unless the engine is running or the prop is spun by hand.

Mechanical cable installation notes

In most cases, the engine side cable adapters supplied with the engine or by the engine manufacturer will work with the SeaStar Solutions Xtreme cables (P/N CCX633xx). If your engines do not have cable end adapters, see table 4-1 below.

Yamaha	Use engine manufacturer's cable adapters*
Honda, Suzuki, Tohatsu	CA27319P**
Evinrude	CA27320P
Mercury	CA27319P

Table 4-1. Engine-Side cable end kits.

* If longer cable ends are required, for Yamaha ONLY use SeaStar Solutions P/N CA38383P adapters

** Require only the cable ends, discard other kit components

4.2.2.1 – Shift Cable Installation

Engine Side

1. Position the engine's shift linkage in the neutral position.
2. Connect the cables to the engine using the appropriate adapters. For new adapter kits, refer to the instructions provided with the kit. If reusing the existing cable ends, position the cable ends approximately half way down the threaded portion of the cable. Always use jam nuts to lock the cable end in place. See figure 4-12.

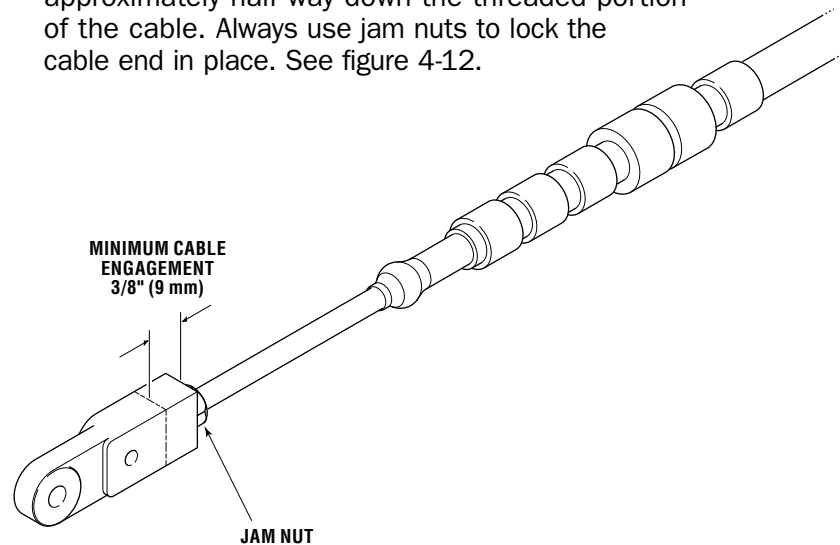

Figure 4-12. Cable End, engine side installation.

⚠ CAUTION

There must always be at least 3/8" of thread engagement on the engine side cable end. See figure 4-12. If correct adjustment cannot be achieved while maintaining 3/8" of thread engagement, longer cable ends may be required.

Actuator Side

1. Position the U-shaped steel retainer clip (A) into the slot on the actuator rack as shown in figure 4-13.
2. Screw the adjustment barrel (B) onto the cable end to the point where the cable can be set into the actuator with the barrel engaging the steel retainer clip (A) and the cable housing groove (C) engaging the cable mount in the actuator. Ensure there is enough cable sticking out of the adjustment barrel (B) to install and tighten the lock nut (D).

NOTICE

If there is not enough cable protruding to install the lock nut, adjust the cable end on the engine side to lengthen the cable at the actuator side.

3. Lay the cable into the actuator and install the dust seal (E).
4. Re-install the actuator cover (See figure 4-11).
5. Repeat for the other shift actuator, if applicable.

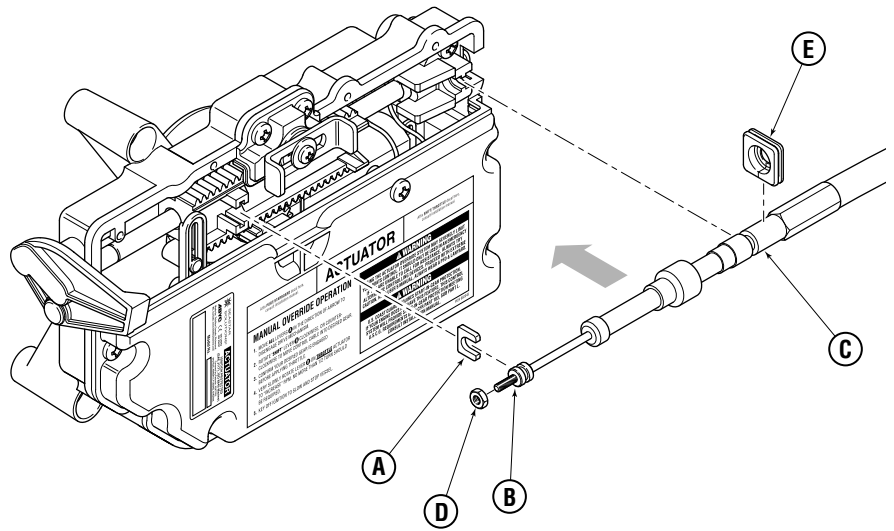

Figure 4-13. Actuator cable installation.

4.2.2.2 – Throttle Cable Installation

Engine Side

1. Put the engine's throttle linkage in the idle position against the idle hard stop.
2. Connect the cables to the engine using the appropriate adapters. For new adapter kits, refer to the instructions provided with the kit. If reusing the existing cable ends, position the cable ends approximately half way down the threaded portion of the cable. Always use locknuts to lock the cable end in place (see figure 4-12). In most cases the original engine adapter may be re-used. In some cases they may not provide adequate adjustability. See Table 4-1 for engine adapter kit part numbers.

⚠ CAUTION

There must always be at least 3/8" of thread engagement on the engine side cable end. See figure 4-12. If correct adjustment cannot be achieved while maintaining 3/8" of thread engagement, longer cable ends may be required.

Actuator Side

1. Position the U-shaped steel retainer clip (A) into the slot on the actuator rack as shown in figure 4-13.
2. Screw the adjustment barrel (B) onto the cable end to the point where the cable can be set into the actuator with the barrel engaging the steel retainer clip (A) and the cable housing groove (C) engaging the cable mount in the actuator. Ensure there is enough cable sticking out of the adjustment barrel (B) to install and tighten the lock nut (D).

NOTICE

If there is not enough cable protruding to install the lock nut, adjust the cable end on the engine side to lengthen the cable at the actuator side.

1. Lay the cable into the actuator and install the dust seal (E).
2. Re-install the actuator cover (See figure 4-11).
3. Repeat steps 1 to 4 for the other throttle actuator, if applicable.

4.2.3 Final Setup and Actuator Adjustment

SHIFT

Successful installation of the shift cables should accomplish the following goals:

- To have shift cables adjusted so neutral position of actuator represents neutral position of engine shift linkage.
- To set the stroke length to achieve full engagement of gear yet not interfere with physical shift linkage limit.
- To have both gears fully disengage when returned to neutral.

⚠ DANGER

THIS PROCEDURE REQUIRES TURNING A PROPELLER BY HAND WITH THE IGNITION ON. USE EXTREME CAUTION.

Procedure

1. Turn ignition on but *do not* start engines.
2. Navigate to **Dealer Menu > Initial Setup > Shift & Throttle > Adjust Port Shift Actuator.**

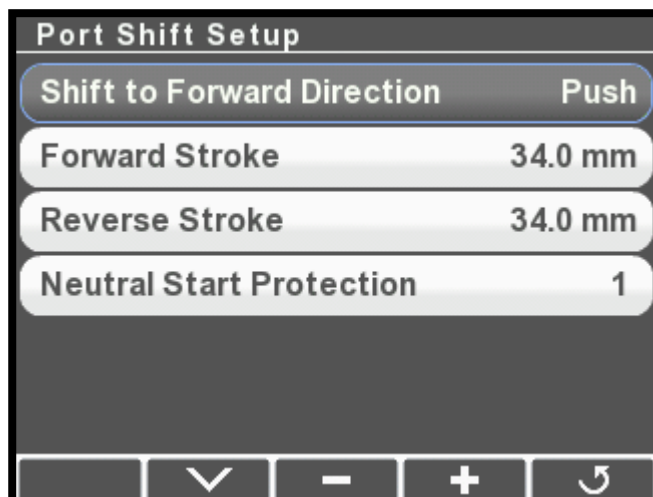

Figure 4-14.

NOTICE

It is not uncommon to have stroke length a little longer for the push direction gear to take up the lost motion of the cable in the push direction. This is more pronounced with longer cables.

3. While an assistant spins the port engine prop by hand, use the control lever to put the port engine into forward gear. Check that the gear engages fully.
4. If the gear does not fully engage, increase the Forward Stroke parameter by 1 mm at a time, press **Save**, and repeat the test until gear engagement is satisfactory.
5. Repeat steps 3 and 4 in reverse gear, this time adjusting the Reverse Stroke parameter.

6. Verify that the engine returns to neutral properly from both forward and reverse gear. The propeller must freewheel in neutral. If it doesn't, adjust the actuator side adjustment barrels until the neutral position is correct. (See section 4.2.2.1 for adjustment.)
7. Repeat steps 2 to 6 for the starboard shift actuator if applicable.
8. Tighten the actuator side lock nut (see figure 4-13) for both shift actuators. Once the final adjustments are made you will need to apply Loctite 242 to the threads, but you will do this after the sea trial.
9. If your engine already has start-in-gear protection you can change the Neutral Start Protection parameter to 0. Otherwise, leave the default value.

THROTTLE

Successful installation of the throttle cables should accomplish the following goals:

- To have throttle cables adjusted evenly so engines *start* to rev up at the same time given the same throttle (handle) position.
- That throttle always returns to idle when handle(s) are moved to idle.
- That there is minimal handle travel before engines rev up.
- That the stroke length is set to achieve wide open throttle (WOT) engine speed without unnecessary throttle cable movement.

Procedure

1. Turn ignition on, do not start engines.
2. Navigate to **Dealer Menu > Initial Setup > Shift & Throttle > Adjust Port Throttle Actuator.**

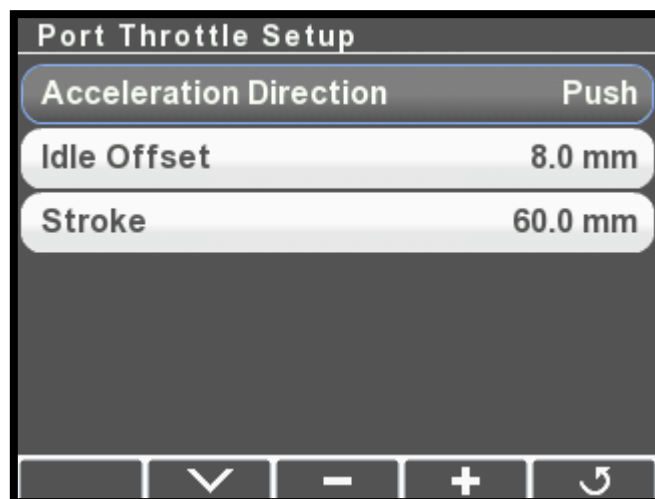

Figure 4-15.

3. Increase the port throttle lever to the full throttle position and verify that the throttle linkage reaches the wide open throttle (WOT) position.

NOTICE

It is not uncommon to have stroke length a little longer for the push direction gear to take up the lost motion of the cable in the push direction. This is more pronounced with longer cables.

4. Increase (or decrease) the Stroke parameter as necessary to reach the WOT position. Press Save after each adjustment to have it take effect.
5. Repeat steps 2 to 4 for the starboard throttle actuator if applicable.
6. Tighten the actuator side lock nut (see figure 4-13) for both throttle actuators. Once the final adjustments are made you will need to apply Loctite 242 to the threads, but you will do this after the sea trial.
7. The Idle Offset parameter is used to fine tune throttle response and to synchronize the throttle actuation.
 - a. On some engines it may take a large amount of lever travel before RPM starts to increase. You can reduce this deadband by increasing the Idle Offset parameter, or by adjusting the actuator adjuster barrels (section 4.2.2.2).
 - b. When both levers are advanced at the same time both engines should start to increase RPM simultaneously. If they do not, you can adjust the Idle Offset parameter (or the actuator adjuster barrels) until they are synchronized.

WARNING

AFTER FINAL ADJUSTMENT IS MADE APPLY LOCTITE® 242 (BLUE) AND TIGHTEN JAM NUT ON ACTUATOR SIDE.

4.3 Control Head Setup

The control head has several configurable parameters, as shown in figure 4-16 below. The default settings will generally provide excellent performance for most boats.

To Access the parameters, navigate to **Dealer Menu > Settings > Shift & Throttle** on your CANtrak display.

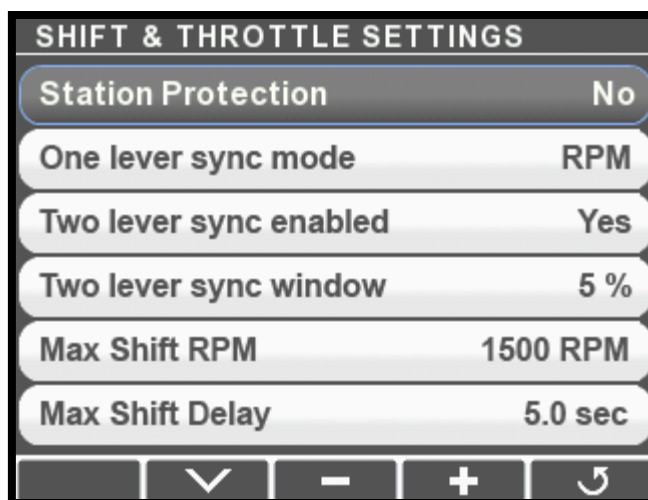

Figure 4-16.

Station Protection	This feature prevents accidental switching between control stations on multi-station boats by requiring a specific sequence of button presses on the control head. The i6800 User's Manual (Book 70) has more information about this feature.
One Lever Sync Mode	Controls the throttle behavior when the Power Train Sync (PTS) feature is engaged. When set to RPM the control system will use engine RPM feedback to match engine speeds. (An engine RPM source is required – see section 3.5.) When set to Throttle the control system will simply match the throttle command.
Two Lever Sync Enabled	When Two Lever Sync is enabled the control system will synchronize engine speeds when both levers are in close to the same position. This feature requires an engine RPM source (see section 3.5).
Two Lever Sync Window	This parameter sets the maximum throttle difference for which Two Lever Sync will function.
Max Shift RPM	Sets the maximum RPM at which a gear shift will be attempted by the control head. It is designed to delay a shift until engine RPM reaches a safe shifting speed.
Max Shift Delay	When there is no engine RPM source present the control software uses a time delay to prevent shifting while engine speed is too high. The Max parameter represents the shift delay (in seconds) if the

control lever has been at 100% throttle for some time and is rapidly moved to another gear. In operation the shift delay is reduced in proportion to the amount of throttle commanded. We recommend that you leave this parameter at the default of 5 seconds, but if you find the shifting is sluggish you can reduce this parameter in small increments.

FWD/REV Throttle Curve

There are two throttle curves that control the response characteristics when the control lever is at or near idle. Curve 1 is the default curve, and is suitable for most applications. Curve 2 requires more lever travel before throttle is increased.

FWD/REV Trolling Max Throttle

Sets the maximum percentage of wide open throttle when trolling mode is engaged. A forward setting of 50% means that when the throttle lever is fully forward the throttle is limited to 50% of maximum. This provides greater throttle sensitivity when moving at slow speeds.

4.3.1 Lever Adjustment

The control lever feel can be adjusted by means of adjusting screws on the forward face of the control head.

- The friction drag on the lever is adjusted with the throttle friction adjuster screw. Turn the screw clockwise to increase the friction on the lever, counter-clockwise to reduce the friction.
- The force required to move in and out of the shift detents is adjusted with the Shift Detent adjuster screw. The detents are meant to prevent accidental gear engagement, so bear that in mind as you make adjustments. Clockwise increases force, counter-clockwise decreases.

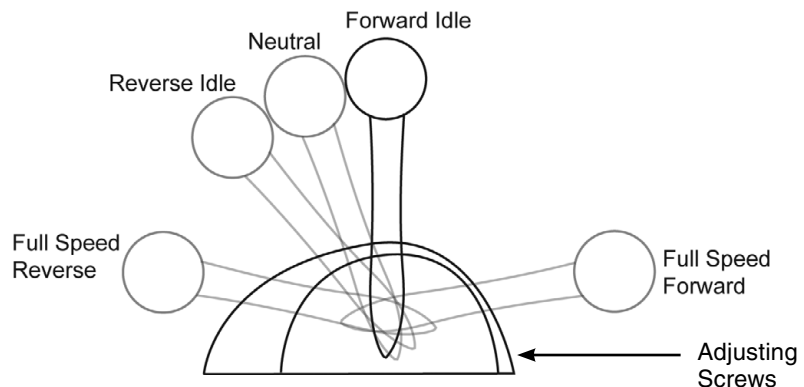

Figure 4-17. Control Head lever positions.

5.0 SEA TRIAL

⚠ WARNING

ALWAYS WEAR A PFD AND CONNECT THE ENGINE LANYARD(S) TO THE OPERATOR DURING SEA TRIAL.

⚠ WARNING

PROCEED CAREFULLY TO DEEP, OPEN WATER TO CONDUCT SEA TRIAL.

Before conducting this sea trial:

- check that both engines shift correctly into forward and reverse gear, and that they respond to throttle inputs.

5.1 Shift Performance

Check that both engines engage gears properly in both forward and reverse, and that they hold in gear under load. Check that they shift correctly into neutral. If necessary, repeat some or all of the shift actuator adjustment in section 4.2.3.

5.2 Throttle Performance

Check that both engines can reach wide open throttle RPM, and that both return to idle properly. Check that the amount of lever travel before RPMs begin to increase is acceptable. Move both levers forward together and check that the RPMs on both engines begin to increase at the same time. If necessary, repeat some or all of the throttle actuator adjustment in section 4.2.3.

Some engine models have sensitive off-idle performance, and may increase RPM quickly with a small movement of the levers from the idle position. The control head has an optional throttle curve that can slow this response if necessary. See section 4.3.

5.3 Control Head Adjustments

During the sea trial you should test the control head features. See the Quick Reference card for instructions.

The control head has adjustable lever friction and adjustable shift detents. Check that the feel of both levers is the same as you shift into and out of gear, and as you increase throttle. Use the adjuster screws on the back of the control head to make any necessary adjustments (see section 4.3.1).

On multi-engine boats engage the Power Train Sync feature and check that engine speeds are matched. If the Sync performance is unsatisfactory you may need to add an engine RPM source. See section 3.5.

Enter Trolling Mode and check that full throttle gives a satisfactory fraction of maximum, and that the low speed control is precise. Adjust the Trolling Max Throttle parameters (section 4.3) if necessary. If there are two control stations, run the vessel from both. Transfer control between control heads and verify that transfer works as it should. If you can't transfer control, check that the Station Protection feature is not enabled.

5.4 Conclusion of Sea Trial

Once you are satisfied with the shift and throttle performance the sea trial is complete.

After returning the vessel to port, check that none of the electrical harnesses and wiring are exposed to water, excessive temperatures, or mechanical damage. Check that all wire splices are properly secured, sealed, and dry. Check that all unused CAN connectors are properly sealed with sealing plugs.

You must also properly secure the actuator adjustment jam nuts (section 4.2):

- Remove the cable access covers.
- Loosen and back off the adjuster barrel jam nuts at the actuators.
- Apply a drop of Loctite Threadlocker Blue 242 to the threads adjacent to the adjuster barrel.
- Tighten the jam nuts against the adjuster barrels.
- Install the actuator cable covers. Be sure to install them to the correct actuator, because the labels that you applied during installation give manual override instructions specific to the actuator's type and instance

6.0 SYSTEM FAULTS & HAZARDS

Should a fault occur, it will be communicated to the user through the control head LEDs. Section 6.1 defines the types of hazards you may experience with the system and how the system will handle each.

NOTICE

When a serious fault occurs, consider your options. While the system has many features to allow the boat to return to port in a slow and safe manner, local conditions or operator skills may dictate that calling for assistance is the prudent thing to do.

6.1 Hazard Definitions

6.1.1 Danger

A danger fault is a critical system fault which will result in limited or no shift and throttle performance and requires immediate action.

Depending on the nature of the fault a variety of conditions might occur all designed to provide the safest situation for returning to port. Some examples are:

- Shift and throttle control may be unavailable for one or more engines.
- The shift and/or throttle may require manual override.

Indication

Dual lever control: both neutral indicator lamps will flash red quickly (5 times per second) until the levers are moved to neutral. When the levers are in neutral the red lamp will flash on the faulted side only.

Single lever control: Both the amber and green lamps will flash quickly.

6.1.2 Warning

A warning is a non-critical system fault which may cause the boat speed to be reduced.

Although a warning fault may not always adversely affect shift and throttle performance, it is an indication of a problem in the system and should be remedied. In some cases the fault can be reset by cycling the system power, but it may require attention from a certified technician.

Indication

Dual lever control: the blue Take Command lamp will flash quickly (5 times per second).

Single lever control: The amber lamp will flash quickly.

This page left intentionally blank.

7.0 WARRANTY

7.1 Statement of Limited Warranty

We warrant to the original retail purchaser that **Marine Canada Acquisition Inc. DBA SEASTAR SOLUTIONS** (herein forward referred to as **SeaStar Solutions**) products have been manufactured free from defects in materials and workmanship. This warranty is effective for two years from date of purchase, excepting that where **SeaStar Solutions** products are used commercially or in any rental or income producing activity, then this warranty is limited to one year from the date of purchase.

We will provide replacement product without charge, for any **SeaStar Solutions** product meeting this warranty, which is returned (freight prepaid) within the warranty period to the dealer from whom such product were purchased, or to us at the appropriate address. In such a case **SeaStar Solutions** products found to be defective and covered by this warranty, will be replaced at **SeaStar Solutions'** option, and returned to the customer.

The above quoted statement is an extract from the complete **SeaStar Solutions** products warranty statement. A complete warranty policy is available in our **SeaStar Solutions** products catalogue.

7.2 Return Goods Procedure

Prior to returning product to **SeaStar Solutions** under warranty, please obtain a *Return Goods Authorization number* (claim number).

Be sure to label the goods with:

- a) the name and address of the sender, and
- b) the return goods authorization number (claim number)

Please address the returned goods as follows:

From U.S.A.

RGA # ?
SeaStar Solutions
c/o UPS-SCS
19308 70th Ave S.
Kent, WA 98032

From Canada

RGA # ?
SeaStar Solutions
3831 No. 6 Road
Richmond, B.C.
Canada V6V 1P6

7.3 Technical Support

Phone: 604-248-3858

email: seastar@seastarsolutions.com

Hours: Monday to Friday 05:00 – 15:30 PST

Web: www.seastarsolutions.com

This page left intentionally blank.

APPENDIX A MOUNTING TEMPLATES

A.1 Control Head – Dual Lever

NOTICE

If you must photocopy this mounting template for use, check ALL measurements using a measuring device prior to using as a template.

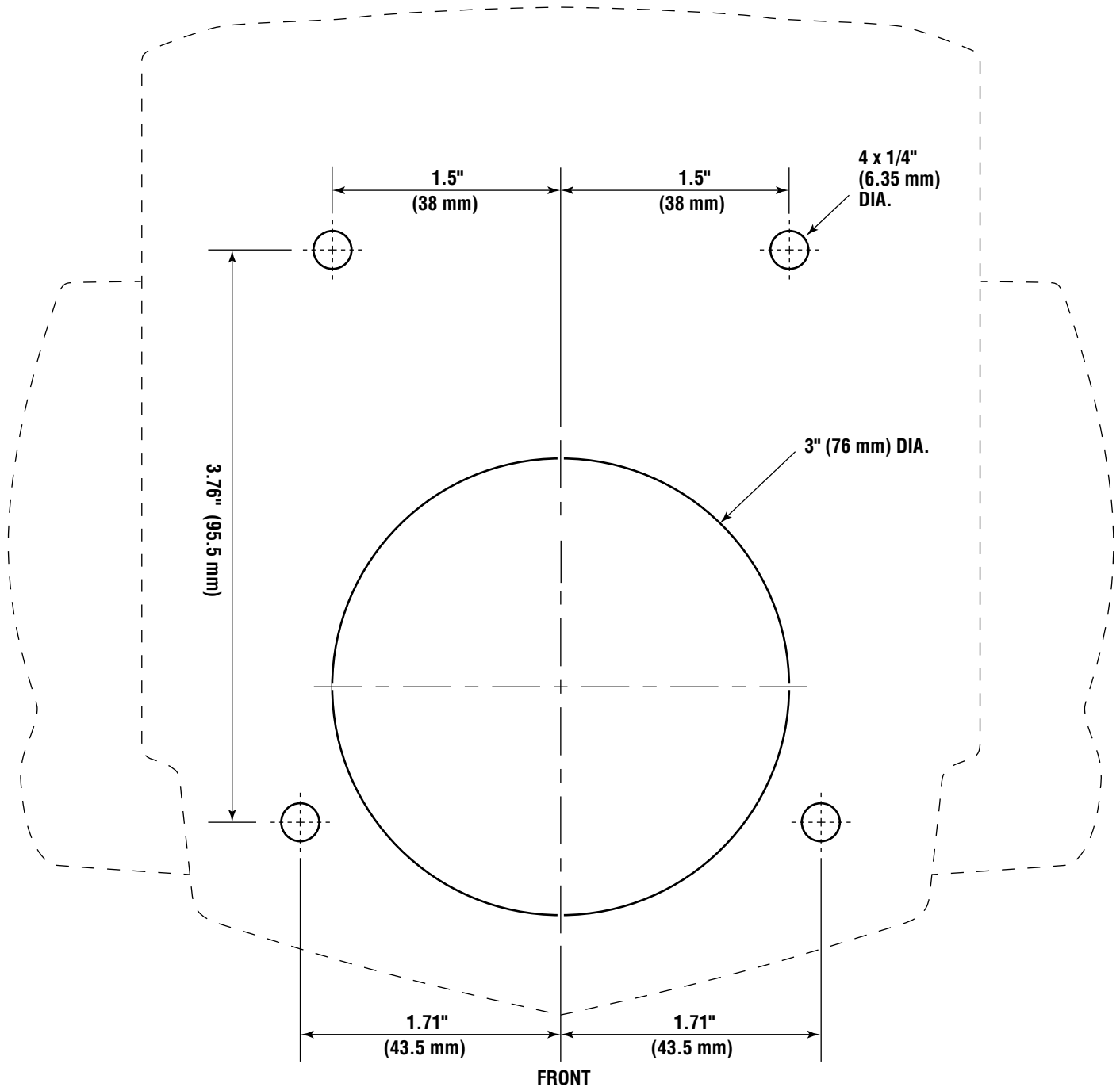

Figure A-1. Control head – dual lever mounting Template.



A.2 Control Head – Single Lever

NOTICE

If you must photocopy this mounting template for use, check ALL measurements using a measuring device prior to using as a template.

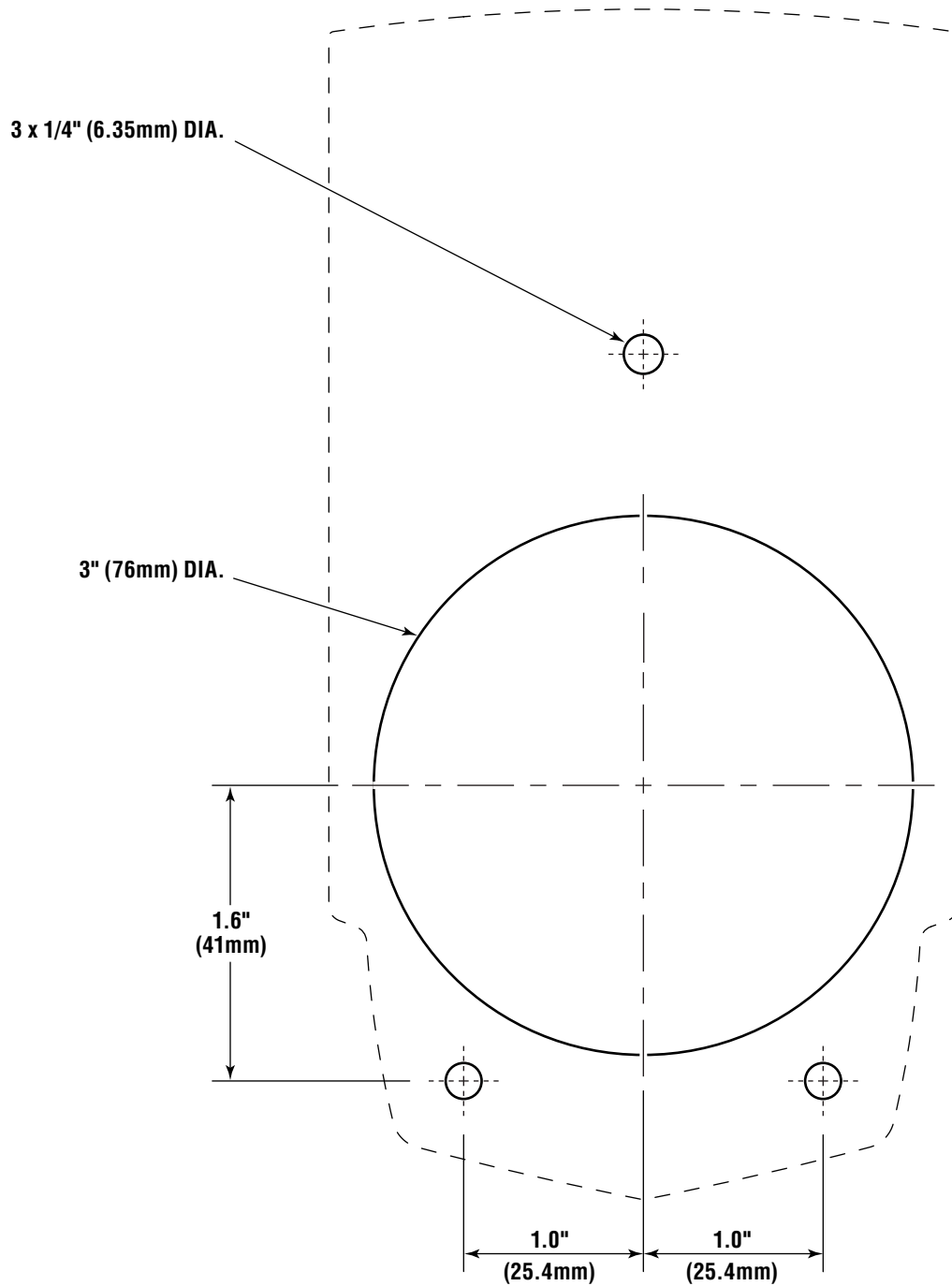

APPENDIX B USING THE COLOR CANtrak DISPLAY

The color CANtrak is a powerful tool that can be used to set up the i6800 actuators and perform software updates. Note that the CANtrak is used as a display on other products, so this section will describe functionality that will not be used for i6800 setup.

B.1 Display Navigation

The five buttons at the bottom of the unit are used to select various actions. The five boxes at the bottom of the display screen will indicate the legend for each button. These legends vary based on what is on the screen.

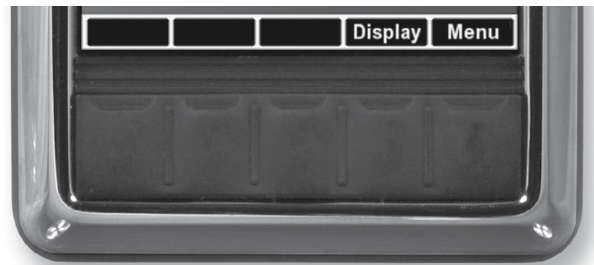







Figure B-1. Navigation buttons and legend.

WORD OR SYMBOL	IDENTIFIES A FUNCTION OR SETTING
	Moves the cursor up the screen to the next item.
	Moves the cursor down the screen to the next item.
	Enters the sub-menu at the cursor location.
	Reduces the setting of the selected item.
	Increases the setting of the selected item.
OK	Accepts a given statement or condition and advances to the next screen.
	Returns to previous menu.
Save	Saves change and returns to previous menu.

B.2 Documentation Conventions

To keep the instructions in the manual as simple as possible, we will use some simple conventions to describe the navigation through the menus. By using these conventions we can easily direct you through several levels of the menu structure.

Bold text Indicates actions that you take on the display. These actions may be button presses, or they may be menu or parameter names.

Capitalized Plain Text Refers to menu and parameter names when describing them.

> When used with the word “press”, refers to the button under the > symbol.
When chained together with text, it is guiding you to select the next item in the chain.

Examples: Press **Save** to save changes and return to the Settings menu.

Navigate to **Dealer Menu > Initial Setup > Steering** to access the System Setup menu.

Let’s look closely at the second example, illustrated in figure B-2.

Dealer Menu tells you to start from the Dealer Menu.

> Initial Setup tells you to highlight the Initial Setup menu item and press > to enter the menu.

> Steering tells you to highlight the Steering item and press > to enter the menu.

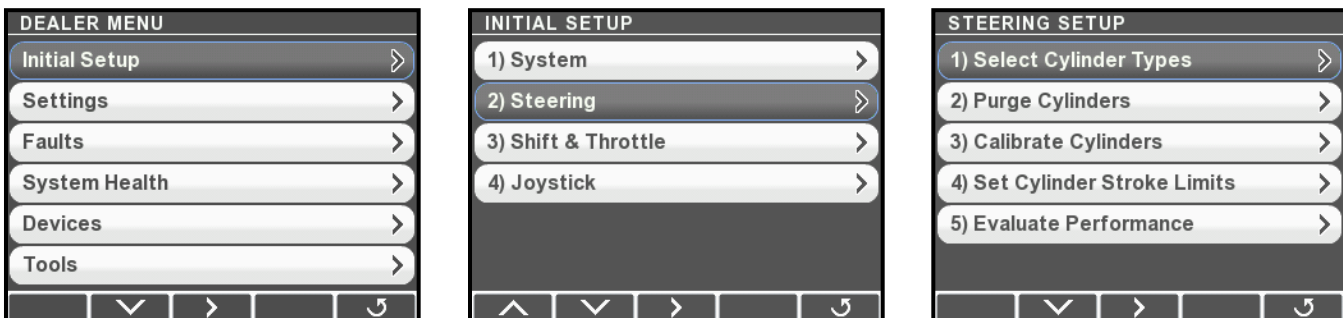

Figure B-2.

You’ll notice that you needed to use the down navigation arrow to select Steering on the Initial Setup screen. You will frequently need to use the up and down arrows to select menus and parameters, but these actions will not be explicitly described.

B.3 Initial Startup

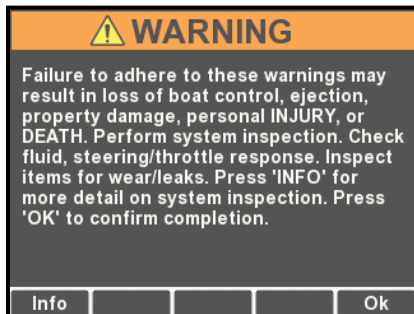

Figure B-3.

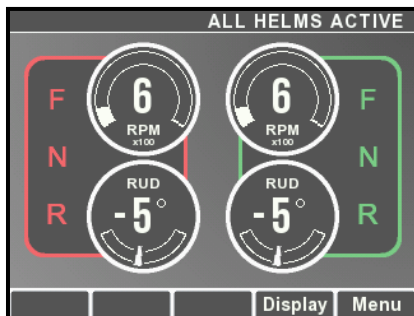

Figure B-4.

When the system power is turned on the CANtrak will display a splash screen, followed by an initial warning screen that prompts the user to perform a system inspection.

Press **Info** to step into the system inspection prompts, or press **OK** to continue. This will take you to the main run screen (also called the All Helms Active screen). If you press **Menu** from the main run screen you will see menus available to the user. (The screen shown is for an Optimus 360 system with joystick – on an EPS system you will not see the gear selection.)

Note: User functionality is not relevant when using the display as a setup tool for EST systems.

B.4 Unlocking the Dealer Menu

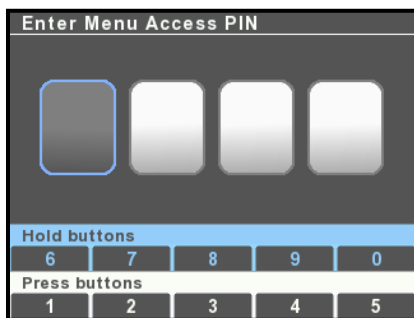

Figure B-5.

All setup and configuration tools are reached from the Dealer Menu, which authorized installers can access with a four digit PIN code (if you don't have a code contact SeaStar Solutions technical support). From the main run screen, press and hold **Menu** until you see the PIN entry screen.

Use the buttons to enter your four digit PIN code. Press the buttons briefly for digits 1-5, press and hold for digits 5-9.

If you enter the code incorrectly you will exit the screen and be placed into the user menu. Press and hold **Menu** again to get back to the PIN entry screen.

Once you have entered the correct code you will go directly to the Dealer Menu. You won't need to enter the code again unless you cycle system power.

NOTICE

The Dealer Menu can be unlocked when faults are active. Faults are suppressed during setup and system updates.

B.5 Menu Structure

The CANtrak display is built with smart menus. The options that are available to you will depend on the system type you set in the initial system setup. The menu structure is extensive, so rather than presenting a map of the entire structure we will highlight the key things you need to know.

Dealer Menu

The Dealer Menu is the base level menu for access to all of the setup tools. There are six submenus available from this screen.

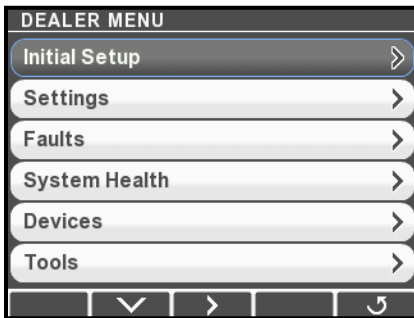

Figure B-6.

Dealer Submenus

Shaded items are hidden on i6800 systems.

INITIAL SETUP

1) System	Set system type, firmware update, set number of devices and their location, select RPM source.
2) Steering	Set cylinder types, purge and calibrate cylinders, set cylinder stroke limits.
3) Shift and Throttle	Adjust shift and throttle settings.
3) Yamaha EST Gateway	Configure EST gateway for Optimus 360 with Yamaha DEC engines.
3) Suzuki EST Gateway	Configure EST gateway for Optimus 360 with Suzuki SPC engines.
4) Joystick	Joystick tuning for Optimus 360.

SETTINGS

System	Control broadcast of RPM and gear selection on CAN3 (NMEA 2000)
Steering	Adjust steering parameters, such as helm effort and number of turns.
Shift and Throttle	Enable station protection and RPM sync, other settings. i6800 EST only.
Yamaha EST Gateway	Yamaha DEC engines only.
Suzuki EST Gateway	Suzuki SPC engines only.
Joystick	Fine tuning for joystick control.
Display	Control user access to steering adjustments.

FAULTS

Shows all active faults. A yellow hazard triangle in place of the > arrow indicates that an active fault is present.

SYSTEM HEALTH

Displays each connected device with a status icon to indicate health.

DEVICES

Lists all devices. From submenu you can find product serial numbers, configure and calibrate the device, monitor inputs and outputs, update firmware, and export or import device settings.

TOOLS

Import and export system settings.

NOTICE

The Dealer Menu can be unlocked when faults are active. Faults are suppressed during setup and system updates.

APPENDIX C SETUP WITH DATALINK

Datalink is a software tool that can be used for system setup and configuration. Although most of these functions can be performed with the color CANtrak display, experienced users may find it quicker to use Datalink for these tasks.

C.1 Dealer Tools

To use Datalink with an i6800 system you will need the following items, supplied with kit EPSK1206:

- IXXAT USB to CAN converter, part #214720
- Programming harness, 6-pin FCI to serial, part #CM21010
- Programming harness, DeviceNet to serial, part #CM21106

You will also need a Windows®-compatible notebook computer with Datalink installed on it. See Appendix D for information on how to download and install the latest version of the software.

C.2 Connection

NOTICE

Always make sure the latest version of Datalink is installed and in use. Check www.optimusdealers.com for latest program revision.

Procedure

1. Connect the notebook computer to an unused CAN2 network port using the CAN2 programming harness as shown in figure C-1. If necessary an additional tee may be installed but *must* be removed or capped after use. If the spare tee is left in the system, there must still be one (and only one) terminator at each end of the CAN2 bus.
2. Turn on the notebook computer and open the Datalink program located on the desktop.
3. Once Datalink opens, the Interfaces section of the Workspace should become populated with components connected to the network. If not, double click on Optimus CAN2 in the protocols section. The components should turn green as communication is established. See figure C-2 to familiarize yourself with the Datalink workspace.
4. Double-clicking on any of the components will enter the configuration pages for that particular component.
5. Before proceeding with the setup, verify that the firmware revisions are up to date for each of the components. Refer to Appendix D for instructions on checking and updating firmware revisions.

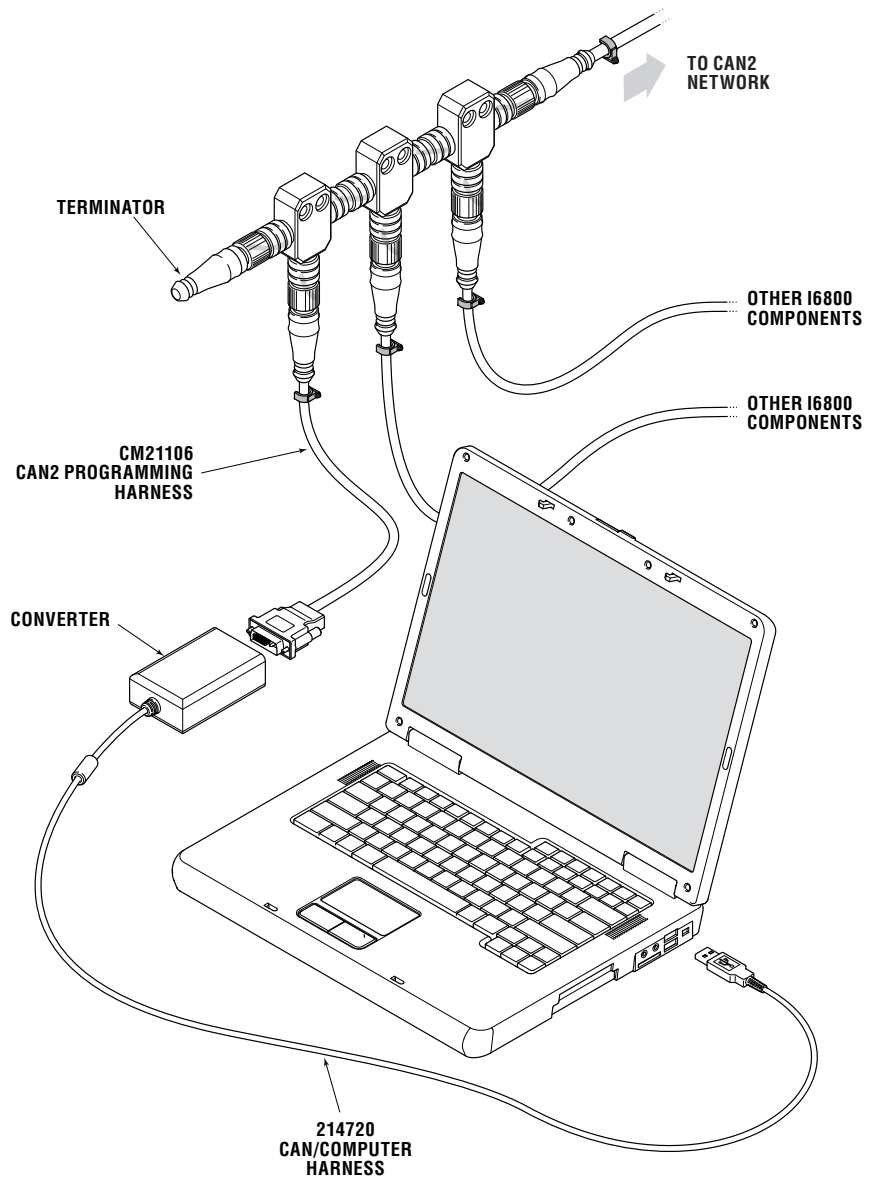

Figure C-1. Dealer Kit connection.

C.3 Navigating Datalink

When you run the Datalink software it will open up with a window similar to the one shown in figure C-2.

At the very top of the display is a series of pull-down menus that access various functions. Just below that is the toolbar, which contains buttons for the most commonly used functions.

The pane on the left is called the Workspace. It is your primary access point to the devices in your system. At the top of the workspace is a list of available Interfaces; these are the devices on the network defined by the selected protocol. In the figure you can see under Protocols that 'Optimus CAN2' is highlighted, so the list of Interfaces is a list of devices connected on the CAN2 network.

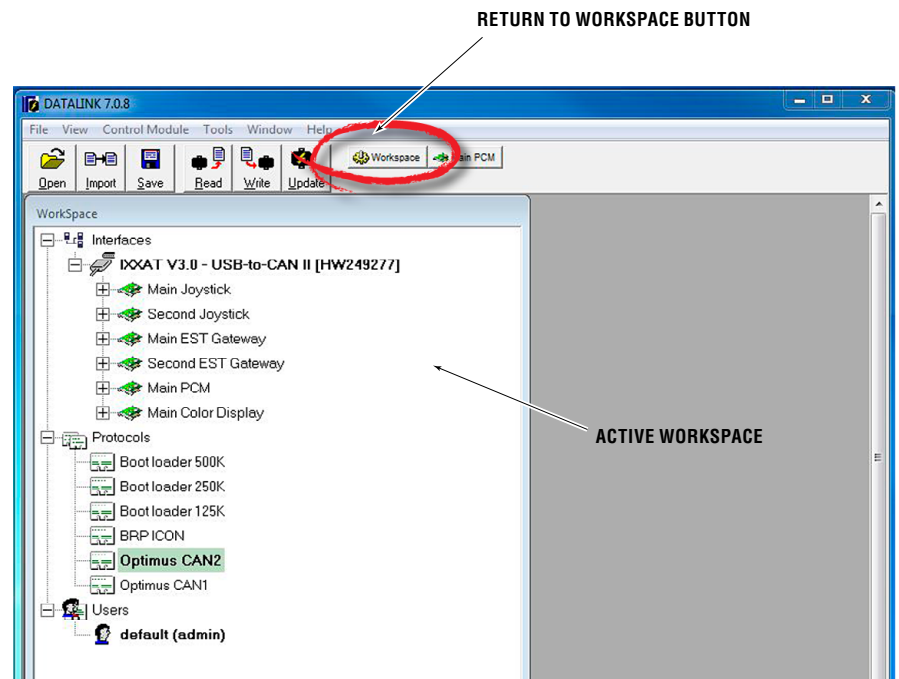

Figure C-2. Datalink Workspace. Your available interfaces may not be exactly as shown.

Double click on a device in the Interfaces list to open the configuration page for that device. Click Workspace in the toolbar at any time to bring up the **Workspace** window.

Important notes about Datalink

Datalink is not like most software packages you are used to. Unlike a word processor, you don't open a file, make changes, and save them. Instead, you open an Interface, which is actually a database that is specially formatted on your screen. The parameter fields (any box with editable values) are cross-referenced to data tables in the devices, but it is not in real-time.

What this means is that the parameters you see are just a snapshot of what is in the device. If you edit these parameters on screen, the changes exist only in Datalink. They will not exist in the device until you click the **Write** button on the toolbar. **Write** takes all the database values that exist in Datalink and copies them to the device, where they are saved in nonvolatile memory (i.e. memory that is not lost when power is removed).

Similarly, clicking **Read** will copy parameters from the connected device into the Datalink database, allowing you to see the current state of the actual device. This is a good way to check that any changes you make have been correctly copied to the device.

For this reason, you will generally not need to use the **Open** and **Save** buttons on the toolbar. They have a different function in the context of Datalink, and aren't used for editing parameters. Likewise, if you are prompted to save changes when you close an Interface, just click **No** and exit. The save function has nothing to do with whether the changes are saved on your device.

C.4 Actuator Setup

C.4.1 Step 1 – Actuator Configuration Using Datalink

This step will establish communication between the shift and throttle actuators and Datalink and will configure the shift and throttle actuator settings. From the factory, all actuators default to being Port Shift actuators. This section will assign the correct function to each of the actuators.

⚠ CAUTION

Ensure mechanical cables are not connected to the actuators at this point.

Procedure

1. In the Datalink workspace you should see two Port Shift Actuators for each engine, as shown in figure C-3 below. Click on the + beside an actuator to view the part and serial number information associated with it.

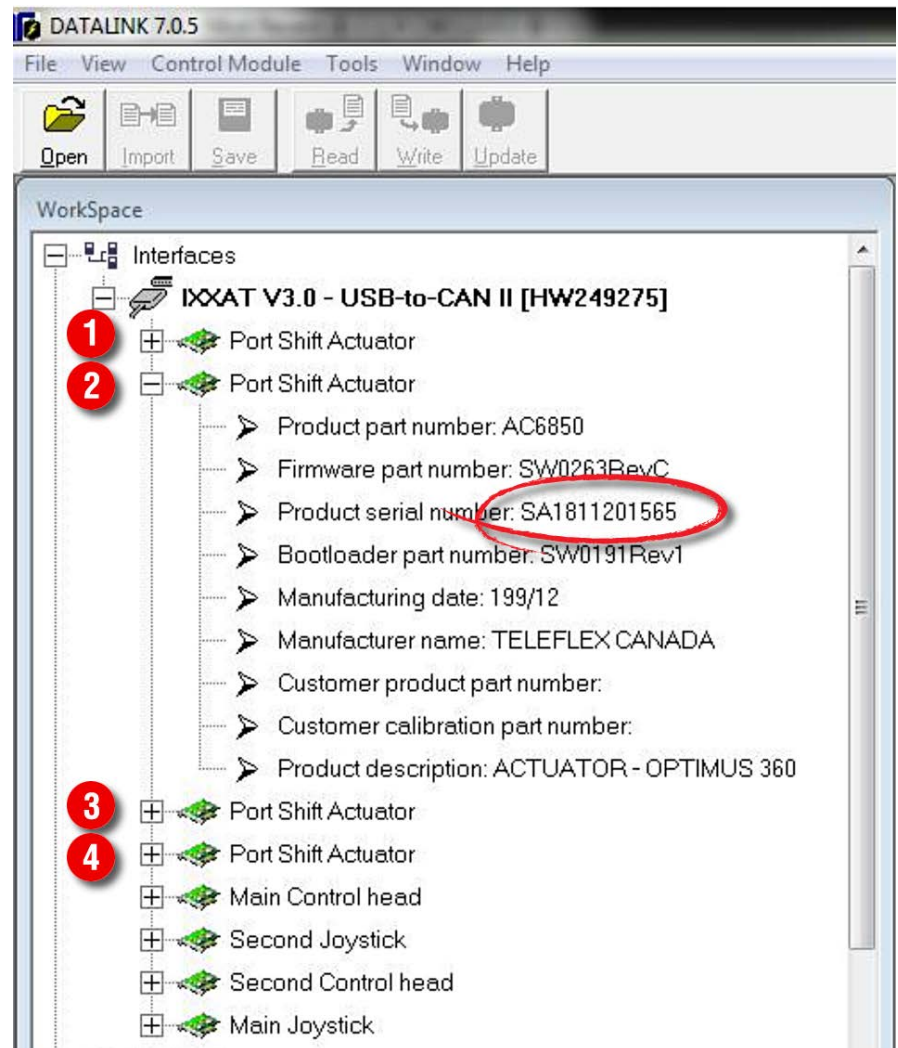

Figure C-3. Shift/Throttle actuator configuration.

1. Match the serial number shown with the serial numbers you recorded in section 3.3.1. You now know the type (shift or throttle) and the instance (port or starboard) of the actuator. Double-click the actuator to open its configuration file.
2. Open the Parameters tab.
3. Set the Actuator Type and Actuator Instance parameter as required. (See figure C-4.) In a single-engine application set the instance for both actuators to Port.
4. Set the type-specific parameters as follows:
 Throttle actuators: Set the Throttle Acceleration parameter to Push or Pull for the direction the throttle actuator is required to move to *increase* throttle.
 Shift actuators: Set the Shift to Forward parameter to Push or Pull for the direction the shift actuator is required to move to engage *forward* gear.
5. Click **Write** to save the changes. The strokes and throws will be set in section C.4.3 after the cables have been installed.
6. Repeat items 1 through 6 for each actuator.
7. Remove cable access covers (See figure C-5) on all actuators. DO NOT connect mechanical cables at this point.
8. With the covers removed, move the port and starboard control head handles to the forward and reverse positions and verify that the shift actuator racks both move accordingly.
9. Increase the throttle on each of the control head handles from idle to the full throttle positions and verify that the throttle actuator racks advance and return to idle accordingly.
10. Apply manual override direction decals as shown in section 4 (figure 4-9 and figure 4-10).

Dealer	
Actuator Type:	Shift
Actuator Instance:	Port
Throttle Acceleration:	Pull
Shift To Forward:	Push
Throttle Offset:	8.0 mm
Throttle Stroke:	60.0 mm
Shift To Forward Throw:	34.0 mm
Shift To Reverse Throw:	34.0 mm
Neutral switch connected	<input checked="" type="checkbox"/>

Figure C-4.

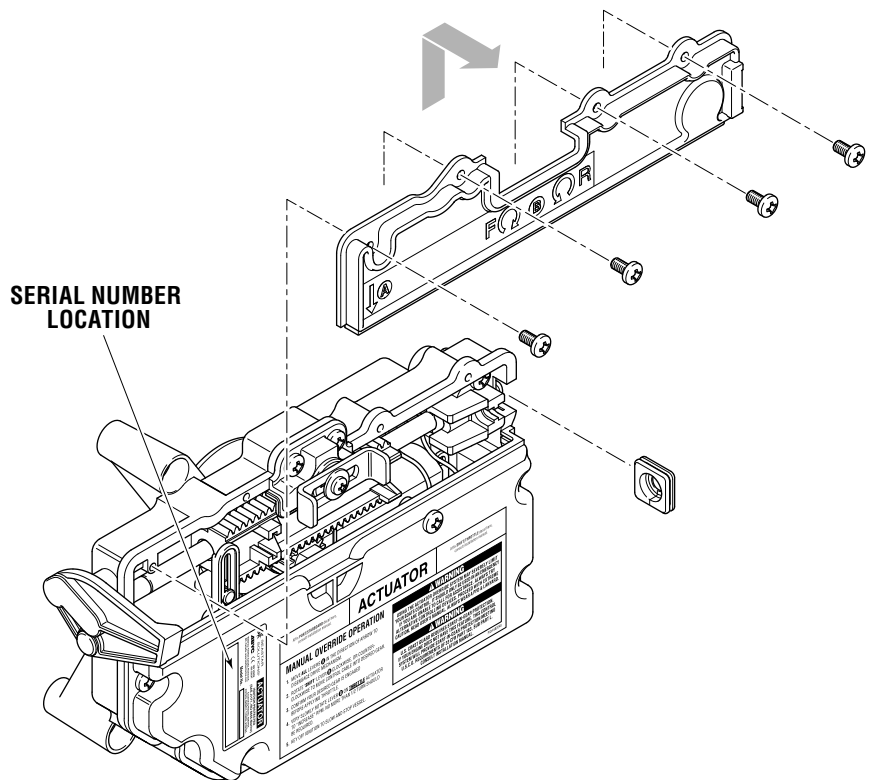

Figure C-5. Actuator cover removal and location of serial number.

C.4.2 Step 2 – Cable Installation and Adjustment

Refer to section 4.2.2 for instructions on the mechanical installation of the cables.

C.4.3 Step 3 – Final Setup and Actuator Adjustment

SHIFT

Successful installation of the shift cables should accomplish the following goals:

- To have shift cables adjusted so neutral position of actuator represents neutral position of engine shift linkage.
- To set the stroke length to achieve full engagement of gear yet not interfere with physical shift linkage limit. (Done in Step 4 below.)
- To have both gears fully disengage when returned to neutral.

⚠ DANGER

THIS PROCEDURE REQUIRES TURNING A PROPELLER BY HAND WITH THE IGNITION ON. USE EXTREME CAUTION.

Procedure

1. Turn ignition on but *do not* start engines.
2. Open the port shift actuator in Datalink.
3. With an assistant spinning the prop by hand, put the port engine into forward gear and verify that the gear engages.
4. Increase the Shift to Forward Throw value 1 mm at a time as necessary to fully engage the gear. Click **Write** to save each change.
5. Repeat items 3 and 4 for reverse gear, modifying the Shift to Reverse Throw value as necessary to fully engage the gear.

⚠ DANGER

THIS PROCEDURE REQUIRES TURNING A PROPELLER BY HAND WITH THE IGNITION ON. USE EXTREME CAUTION.

6. Verify that the engine returns to neutral properly from both forward and reverse gear. The propeller must freewheel in neutral. If it doesn't, adjust the actuator side adjustment barrels until the neutral position is correct. (See Section 4.2.2.1 for adjustment.)
7. Repeat items 2 to 6 for the starboard shift actuator if applicable.
8. Tighten the actuator side lock nut (see figure 4-13) for the shift actuators. Once the final adjustments are made you will need to apply Loctite® 242 to the threads, but you will do this after the sea trial.
9. If your engine already has start-in-gear protection you can uncheck the box labeled "Neutral switch connected."

NOTICE

It is not uncommon to have stroke length a little longer for the push direction gear to take up the lost motion of the cable in the push direction. This is more pronounced with longer cables.

THROTTLE

Successful installation of the throttle cables should accomplish the following goals:

- To have throttle cables adjusted evenly so engines *start* to rev up at the same time given the same throttle (handle) position.
- That throttle always returns to idle when handle(s) are moved to idle.
- That there is minimal handle travel before engines rev up.
- That the stroke length is set to achieve wide open throttle (WOT) engine speed without unnecessary throttle cable movement.

Procedure

1. Turn ignition on, do not start engines.
2. Open the port throttle actuator in Datalink.
3. Increase the port throttle lever to the full throttle position and verify that the throttle linkage reaches the wide open throttle (WOT) position.
4. Increase the Throttle Stroke value in Datalink as necessary to reach the WOT position. Click **Write** to save each change.
5. Repeat items 2–4 for the starboard throttle actuator if applicable.
6. Tighten the actuator side lock nut (see figure 4-13) for both throttle actuators. Once the final adjustments are made you will need to apply Loctite 242 to the threads, but you will do this after the sea trial.
7. The Idle Offset parameter is used to fine tune throttle response and to synchronize the throttle actuation.
 - a. On some engines it may take a large amount of lever travel before RPM starts to increase. You can reduce this deadband by increasing the Idle Offset parameter, or by adjusting the actuator adjuster barrels (section 4.2.2.2).
 - b. When both levers are advanced at the same time both engines should start to increase RPM simultaneously. If they do not you can adjust the Idle Offset parameter (or the actuator adjuster barrels) until they are synchronized.

⚠ WARNING

AFTER FINAL ADJUSTMENT IS MADE APPLY LOCTITE® 242 (BLUE) AND TIGHTEN JAM NUT ON ACTUATOR SIDE.

C.5 Control Head Setup

The control head has several configurable parameters, as shown in figure C-6 below. The default settings will generally provide excellent performance for most boats.

Access the parameters by double-clicking on the Main Control Head in the Datalink interface list, then clicking on the Parameters tab. A reset function is provided so that default values can be restored at any time. Remember to click **Write** after making any changes.

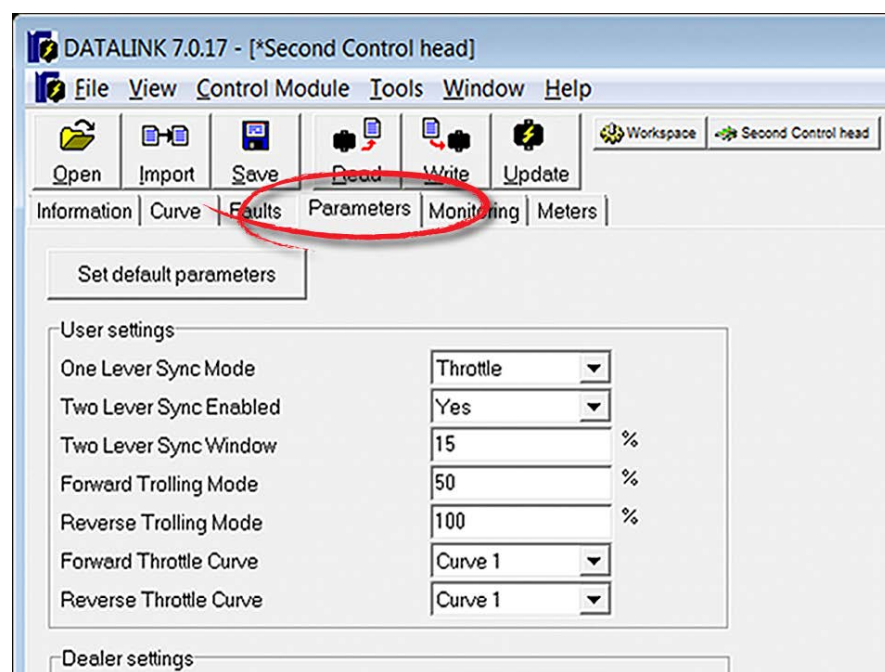

Figure C-6. Control Head setup.

The functions of these parameters are as follows:

One Lever Sync Mode – Controls the throttle behavior when the Power Train Sync (PTS) feature is engaged. When set to RPM the control system will use engine RPM feedback to match engine speeds. (An engine RPM source is required – see section 3.5.) When set to Throttle the control system will simply match the throttle command.

Two Lever Sync Enabled – When Two Lever Sync is enabled the control system will synchronize engine speeds when both levers are in close to the same position. This feature requires an engine RPM source (see section 3.5).

Two Lever Sync Window – This parameter sets the maximum throttle difference for which Two Lever Sync will function.

Forward/Reverse Trolling Mode – sets the maximum percentage of wide open throttle when trolling mode is engaged. A forward setting of 50% means that when the throttle lever is fully forward the throttle is limited to 50% of maximum. This provides greater throttle sensitivity when moving at slow speeds.

Forward/Reverse Throttle Curve – There are two throttle curves that control the response characteristics when the control lever is at or near idle. Curve 1 is the default curve, and is suitable for most applications. Curve 2 requires more lever travel before throttle is increased.

Station Protect – When enabled (Yes), this feature prevents accidental switching between control stations on multi-station boats by requiring a specific sequence of button presses. Refer to Book 70– i6800 User Manual for more information.

Control Head Instance – If you are setting up a second station, change this parameter to Second.

Shift and Throttle Type – Ensure this parameter is set to SeaStar i6800.

APPENDIX D UPDATING FIRMWARE

NOTICE

This section contains instructions for i6800 Shift and Throttle System, Optimus EPS and Optimus 360 systems.

From time to time it may become necessary to update the Datalink notebook software and the i6800 component firmware as new versions become available.

Check www.optimusdealers.com for latest available firmware. The updates are packaged in a single download file called 'Optimus and Optimus 360 Datalink Updater Version X', where X indicates the revision. A readme file describes the nature of the updates, the component revision files included in the package, and any special instructions. **ALWAYS** read the readme file prior to updating. The readme file can be accessed from the Datalink 'Help' menu. Click 'Help,' then click 'readme.txt' to view the file.

When run, the Updater will first install the latest version of Datalink on your computer, then automatically load the latest firmware files to the notebook computer and put them in the [Desktop\Optimus Firmware] folder. Each component update file will be in a separate folder with the component name. See Figure D-1.

Name	Date modified	Type
Actuator Shift_Throttle	4/15/2013 11:00 AM	File folder
CANTrak	4/15/2013 11:00 AM	File folder
Control_Head	4/15/2013 11:00 AM	File folder
EPS_Helm	4/15/2013 11:00 AM	File folder
EST	4/15/2013 11:00 AM	File folder
Joystick	4/15/2013 11:00 AM	File folder
PCM	4/15/2013 11:00 AM	File folder

Figure D-1. Desktop\Optimus Firmware – Folder Structure.

NOTE: The installer only loads the required files to the computer; it does NOT perform the actual component updates. Refer to section D.2 for detailed component updating instructions.

D.1 Checking Component Firmware Revision Levels

The current firmware version installed in a component can be checked through Datalink.

NOTE: When opening component windows in Datalink, it is good practice not to have more than two components open at a time to avoid potential communication errors.

D.1.1 Using DATALINK

1. Connect the computer to the i6800 system as shown in section C.2.
2. In the 'Interfaces' section in Datalink, click on the  box to expand the component information. See figure D-2. (In an i6800 system you will see only the Control Head(s) and Actuators in the component list.)
3. Firmware revision can be found under the 'Firmware Part Number' field.

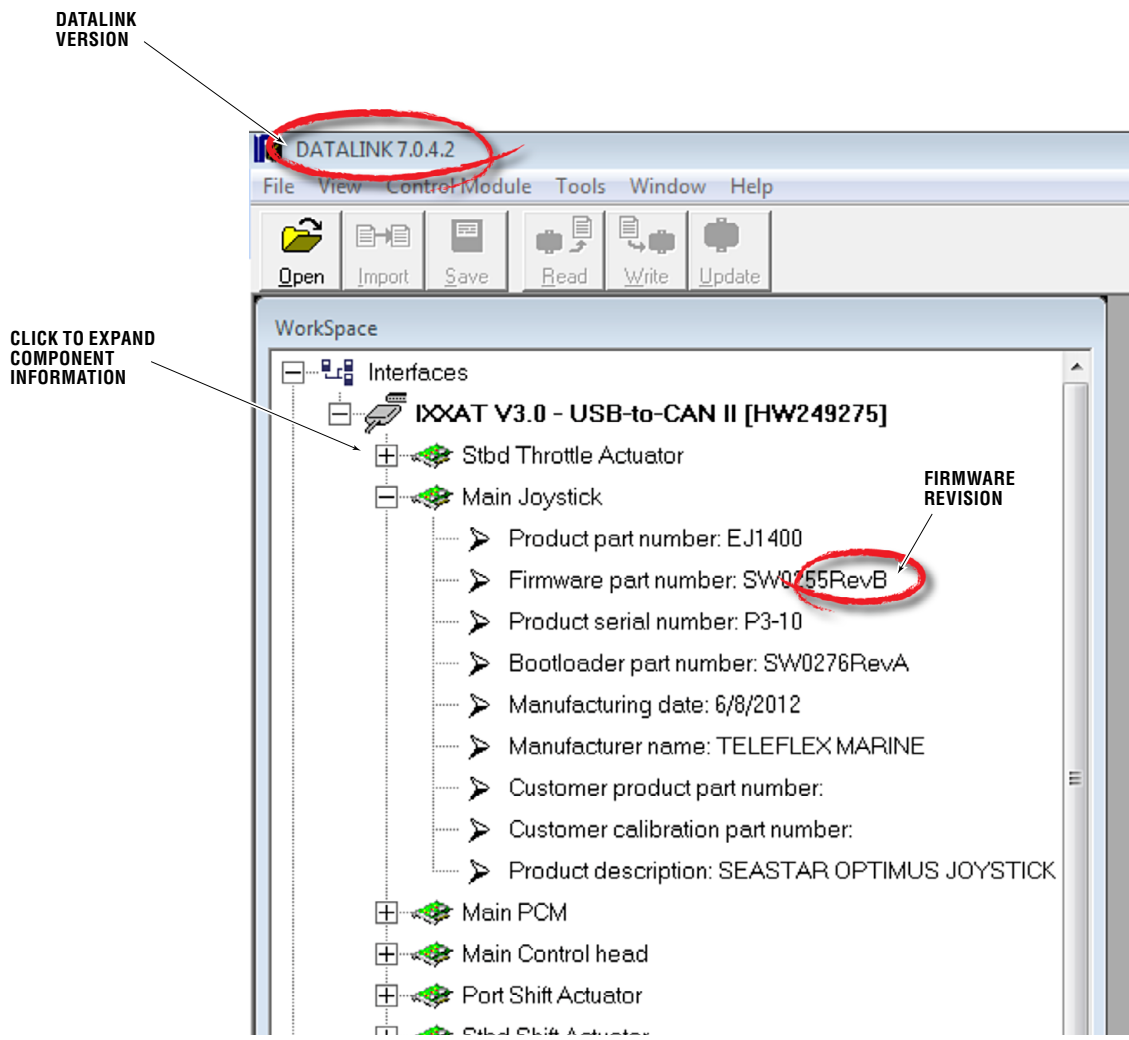

Figure D-2. Datalink workspace.

D.2 Updating Actuators and Control Head

NOTICE

Please contact SeaStar Solutions Technical Support before attempting to update your system firmware. Not all new software releases will be compatible with your system. These instructions are provided for your information only, and assumes that you are updating your firmware under guidance.

Procedure

1. Navigate to www.optimusdealers.com and download the latest file updater package to the notebook computer's Desktop.
2. Double click on the updater to install the files on the computer.
3. Navigate to the readme file at [Desktop\Optimus Firmware] and check the readme file for any special instructions.
4. Connect the notebook computer to the system and open Datalink as outlined in section C.2.
5. Double click on the component to be updated to enter the configuration pages for that particular component.

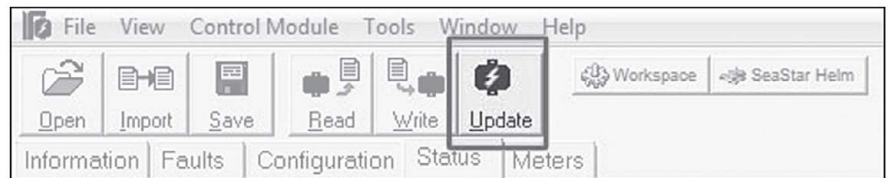

Figure D-3. Top Toolbar.

6. Select 'Update' on the top toolbar. Click box 'select update file' & navigate to the appropriate update file in [Desktop\Optimus Firmware\Update Files]. Each update file will be located in a folder with the component names (see figure D-1). See table D-1 for component and file name cross reference.

Component	Update File
Actuators	SW0263Rev[].s19
Control Head	SW0262Rev[].s19

Table D-1. Update File Names.

7. Click 'Open' to begin the update process. A window will pop up asking if you are sure that you want to update. Click 'Yes'.
8. Once the update is complete, a popup box states that the new application was successfully loaded and to reset power to complete operation. Click 'OK' to close the control module update box and close Datalink.

NOTICE

Failure to close Datalink may result in some components not updating properly. Always close all components and the Datalink program after an update.

9. Key off all ignition switches for 2 to 4 seconds to power down the system.

10. Key on and power up the i6800 system.
11. Reconnect to the system using Datalink. (It may take a moment for the components to become visible in Datalink)
12. Verify that the latest revision of firmware was loaded to the component as per Section D.1.
13. Repeat steps 5 through 13 for any other components which may require updating.

NOTE: In some cases, configuration values may need to be manually re-entered after an update. The readme files will instruct to do so if necessary so **ALWAYS** read the readme file prior to updating.

NOTE: When opening component windows in Datalink, it is good practice not to have more than two components open at a time to avoid potential communication errors.

NOTE: When updating components, it is common to have warning indications on the control head. These can be ignored, but no active faults should be present after completion of the updating process.

D.3 Updating the CANtrak Software

The CANtrak software can only be updated from the display. You will need a USB drive (preferably empty) and a computer to perform the update.

Procedure

1. If you haven't already done so, download and install the file updater (page D-1).
2. Find the Optimus Firmware folder on your desktop and open it, then open the Color CANtrak folder.
3. In the Color CANtrak folder you will find a .zip file. Double-click on it to view the files in the folder.
4. Copy all the files to the root level of your USB drive. Don't put them in a file folder.
5. Plug the USB drive into the port on the back of the CANtrak. If your system is off, turn it on now.
6. The software update process is automatic. When prompted, remove the USB drive from the display. The display will reboot into the updated software version.
7. Delete the files you copied to the USB drive. If you don't, you won't be able to use the USB drive for other CANtrak functions.

© 2014 MARINE CANADA ACQUISITION INC.
DBA SEASTAR SOLUTIONS

PRINTED IN CANADA 04/18

Please scan
this QR code
and watch our
latest **Boating
Safety** video.



SEASTAR SOLUTIONS
3831 NO.6 ROAD
RICHMOND, B.C.
CANADA V6V 1P6

FAX 604-270-7172

www.seastarsolutions.com

ISO 10592



FORM NO. 710100 REV. C

