

MEMBER
ABYC
Setting Standards for Safer Boating

35

THIRTY FIVE
ISO 9001

BAYSTAR™

CAPILANO™

SEASTAR™

INSTALLATION INSTRUCTIONS AND OWNER'S MANUAL

www.seastarsolutions.com

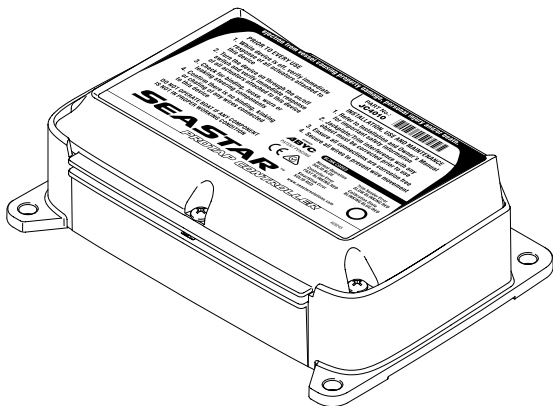

SEASTAR™ *PROTAP CONTROLLER*

For the ultimate in Engine
position control



**SEASTAR
SOLUTIONS®**

*Before you do it your way,
please try it our way*

To the Installer and End User (Owner)

Thank you for choosing SeaStar ProTap Controller. This Installation and Owner's Manual contains all the information that you and others will require for the safe installation and use of the ProTap Controller and MUST remain on board the boat. Throughout this manual information for the safe installation and use of the controller will be distinguished in one of the following ways:

WARNING

Hazards or unsafe practices which could result in severe personal injury or death.

Failure to adhere to a warning may lead to loss of steering control. Loss of steering control may result in unpredictable boat behavior, leading to ejection from boat causing property damage, personal injury and/or death.

CAUTION

Hazards or unsafe practices which could result in minor injury or product or property damage.

NOTICE

Important information in regards to installation, use and maintenance of the steering components.

NOTICE

Marine Canada Acquisition Inc. DBA SEASTAR SOLUTIONS is referred to as SeaStar Solutions throughout this publication.

These safety alerts alone cannot eliminate all of the hazards that may be present while on the water. SeaStar Solutions recommends that all users of the steering system take an accredited 'boating safety course', follow safe boating practices and are made aware of the environment that they will be in.

INDEX

1.0 Introduction	ii
2.0 Safety Information	1
2.1 General.....	1
2.2 Important Labels.....	2
3.0 System Overview	5
3.1 How The System Works	5
3.2 System Diagrams	6
4.0 Installation	12
4.1 Wiring	12
4.2 Installation Overview	19
5.0 Calibration Procedure	20
6.0 Operating Modes	23
6.1 Bass/Bay B-Mode (Part # JC4010).....	23
6.2 Flats F-Mode (Part # JC4020)	24
7.0 Troubleshooting	25
8.0 Warranty	26
8.1 Statement of Limited Warranty.....	26
8.2 Return Goods Procedure.....	26
8.3 Technical Support	26
9.0 Appendix	27
9.1 CAN Basic Network.....	27

1.0 INTRODUCTION

Before proceeding with the installation, read these instructions thoroughly. SeaStar Solutions cannot accept responsibility for installations where instructions have not been followed, where substitute parts have been used, or modifications have been made to our products. Warranty may be void if products other than SeaStar Solutions products are used with this system.

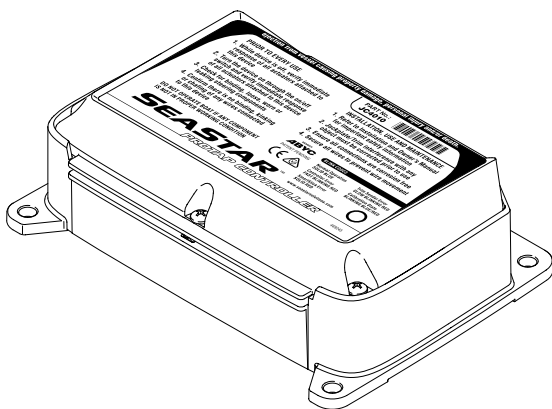

Figure 1-1.

2.0 SAFETY INFORMATION

2.1 General

WARNING

The safety information provided below is intended to inform you of the dangers that may be present before, during and after the installation. It is critical that you read and understand ALL the points noted.

The safe operation of the controller is dependent upon proper installation and maintenance, common sense, safe judgment and the knowledge/expertise of the operator. Every installer/user of the controller should know the following requirements 'before' installing/using the controller.

If you have any questions regarding any of these warnings, contact SeaStar Solutions.

To reduce risk of severe injury or death. Always wear a Coast Guard Approved personal flotation device (PFD) and use an engine shut-off cord (lanyard).

Before installation

1. Read and understand the Installation and Owner's Manual provided with your controller.
2. Ensure that all components required to complete the installation are on hand (including wires, terminals and the proper tools required for the installation).
3. SeaStar components are highly engineered and safety tested to ensure system integrity, DO NOT substitute any component with non-SeaStar components as this may compromise system performance/reliability.

Installation

1. Install the controller and the components that connect to the controller as directed in appropriate Installation Manuals.
2. DO NOT modify or substitute any component in any way without written consent from SeaStar Solutions.
3. Comply with all system ratings/regulations (boat/engine, U.S.C.G.).

WARNING

4. **Confirm that there is no interference between the steering cylinder(s), tiebars and the transom, splashwell, outboard engine or Jackplate or any combination of these parts by performing the following steps;**
 - a) With engine fully tilted DOWN, turn steering wheel from hard over to hard over and confirm that no interference occurs.
 - if using a hydraulic jack plate the above must also be performed at all the positions of the Jackplate.
 - b) Repeat step 'a' with engines tilted UP.
 - c) Perform step 4a) with each engine in DOWN/UP positions confirming that independent TRIM/TILT can be done without any interference.

5. Confirm that the steering cylinder can be fully stroked in both directions as well as full tilt and trim without stretching, chafing, rubbing and/or kinking of the hydraulic hoses.
6. Confirm that extruded nylon tubing has NOT been substituted for SeaStar Steering Hose.

Prior to Every Use

1. While device is off, verify immediate response of all actuators attached to this device.
2. Turn the device on through the on/off switch and verify immediate response of all actuators attached to this device.
3. Check for binding, loose, worn or leaking steering or Jackplate components.
4. Confirm there is no binding, kinking or chafing of any wires connected to this device.

⚠ WARNING

Do not operate boat if any component is not in proper working condition.

2.2 Important Labels

The safety information provided below is intended to inform you of the warning information on your product. Please contact SeaStar Solutions if the label is missing.



Figure 2-1.

Ensure the dash decal is placed in a visible location on the dash after the ProTap installation.

⚠ WARNING

The boat operator must be made aware that trim and Jackplate operation is different. It is critical that they get acquainted to ProTap operation using this user manual or quick reference card. Failure to do so may result in injury and/or loss of vessel control, leading to possible ejection from vessel causing property damage, personal injury and/or death.

**SEASTAR™
PROTAP CONTROLLER**

This boat is equipped with ProTap engine position controller

Please see quick reference card or user manual for instructions. 469192

Figure 2-2. Dash Decal.

Refer to the B-Mode and F-mode quick user guide for reference on how to use the ProTap system effectively.

**SEASTAR™
PROTAP CONTROLLER**

B-MODE Quick User Guide

Consult boat user guide for the location of controller ON/OFF switch.

To **memorize** current Jackplate or Trim position.

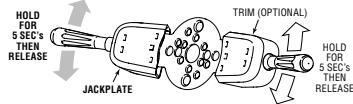

To **recall** memorized Jackplate or Trim position.

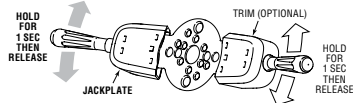

For **quick controlled motion** in set increments.

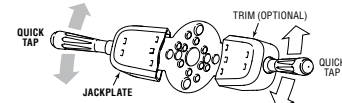

⚠ WARNING

READ BOAT OPERATOR'S AND PROTAP OWNER'S (BOOK 35) MANUALS BEFORE USE.

⚠ WARNING

ADJUSTING ENGINE TRIM OR JACKPLATE HEIGHT CAN AFFECT STEERING CONTROL AND BOAT STABILITY. ENSURE BOAT IS STABLE AND SAFE TO STEER AFTER MAKING ENGINE TRIM OR JACKPLATE ADJUSTMENTS.

How to adjust engine Trim and Jackplate:

- Before moving from stationary position, lower the Jackplate and trim fully down.
- After applying throttle, trim the engine up. This will lift the bow of the boat and aerate the hull. Continue adjusting trim for optimal ride performance, engine RPM and boat speed.
- Lift the Jackplate up to reduce engine drag, adjusting as needed for optimal ride performance, engine RPM and boat speed.



www.seastarsolutions.com
© 2017 Marine Canada Acquisition Inc.
DBA SEASTAR SOLUTIONS



PDF# 469547A
02/17 Printed in Canada

Figure 2-3. Bass/Bay Mode Quick User Guide.

SEASTAR™ PROTAP™ CONTROLLER

F-MODE Quick User Guide

Consult boat user guide for the location of controller ON/OFF switch.

⚠ WARNING

READ BOAT OPERATOR'S AND PROTAP OWNER'S (BOOK 35) MANUALS BEFORE USE.

⚠ WARNING

ADJUSTING ENGINE TRIM OR JACKPLATE HEIGHT CAN AFFECT STEERING CONTROL AND BOAT STABILITY. ENSURE BOAT IS STABLE AND SAFE TO STEER AFTER MAKING ENGINE TRIM OR JACKPLATE ADJUSTMENTS.

To quickly move Jackplate all the way up or down.

2X QUICK TAPS

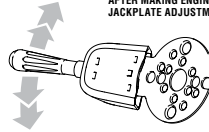

To move Jackplate in 2" increments.

QUICK TAP

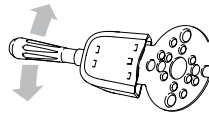

For fine Jackplate motion.

HOLD

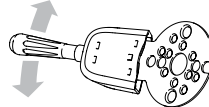

www.seastarsolutions.com
© 2017 Marine Canada Acquisition Inc.
DBA SEASTAR SOLUTIONS



PID# 469548A
60-02/17 Printed in Canada

Figure 2-4. Flats Mode Quick User Guide.

3.0 SYSTEM OVERVIEW

3.1 How The System Works

Overview

ProTap controller is a NMEA 2000 CAN enabled device designed to give you an additional level of control over Jackplate and Trim position. It offers you an ability to quickly get your boat to speed without a need to look at the gauges. When controller is turned off your Jackplate and Trim switches will operate Jackplates and engine trim in open-loop control, denoted as "Normal" mode. When the controller switch is on it will engage "Smart" operating mode. For Trim control or Tilt protection please refer to table 4-2 for the additional harness needed to connect the controller to engine trim sender or the NMEA 2000 CAN network.

The controller can be wired to:

- Control one Jackplate
 - Optional: connect trim information to ProTap for the tilt protection feature
- Control one Jackplate and one engine trim
 - this configuration requires engine trim information
- Control two Jackplates
 - Jackplate position is synced
 - Optional: connect trim information to ProTap for the tilt protection feature

Please refer to figure 3-4, figure 3-2 and figure 3-3 for connection details

The controller comes pre-programmed in one of the two operating modes:

Bass/Bay B-Mode (Part # JC4010)

This mode is designed to get you up to speed quickly while helping you maximize your boat performance predictably. You can memorize your favorite Jackplate and trim settings for quick recall later.

Flats F-Mode (Part # JC4020)

This mode is designed allow you to quickly move the Jackplate to pre-programmed positions. A quick single or double tap on a toggle switch will move the plate to one of the presets.

You can memorize your favorite trim positions for quick recall later.

Tilt Protection

If trim information is connected, the Jackplate will move up to a "safe" position when engine in tilt range. This will ensure that when engine is fully tilted there is no contact between the boat transom and engine or steering.

3.2 System Diagrams

Single Jackplate (Gauge Optional)

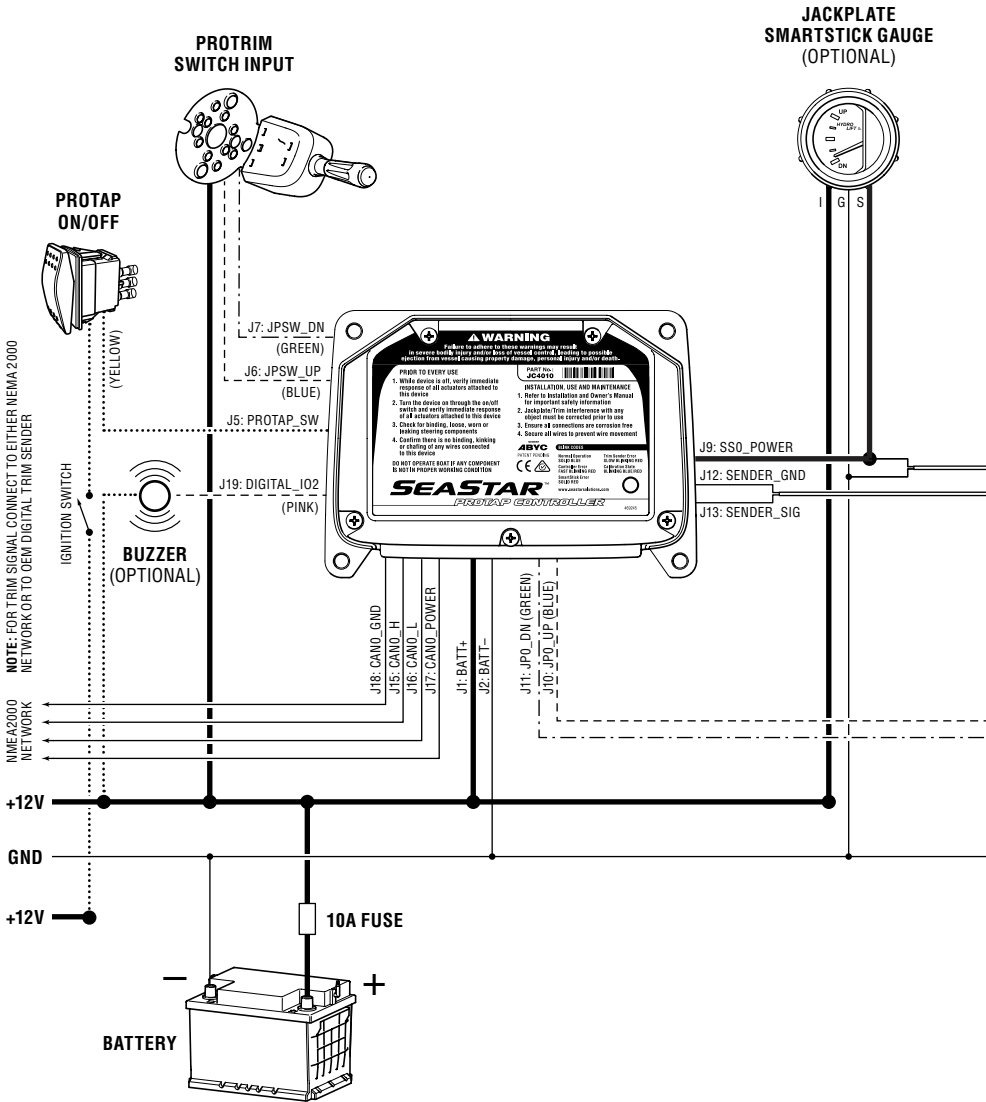
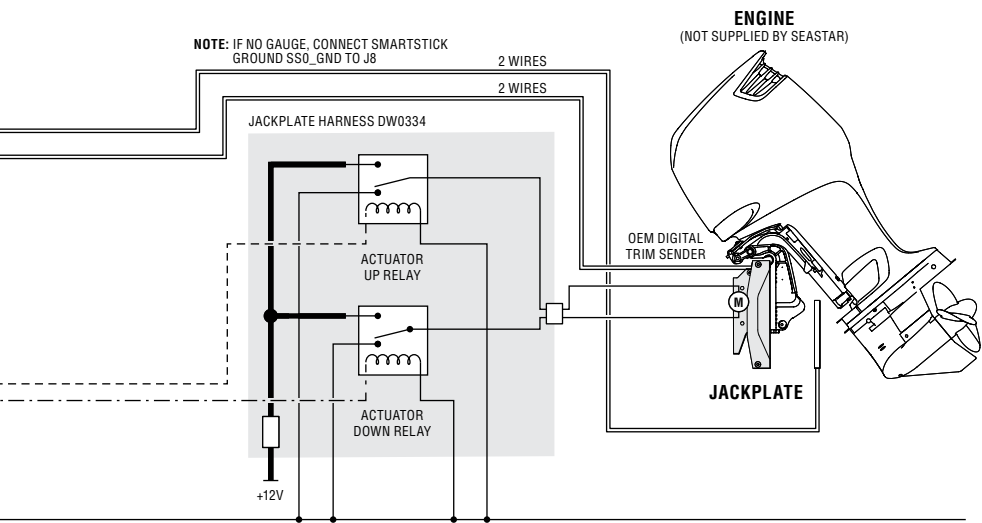

Figure 3-1. Single Jackplate and Gauge.



Referring to figure 4-1 on page 12 match the wiring in the schematic to the pin on the controller.

Single Jackplate and Trim (Gauge Optional)

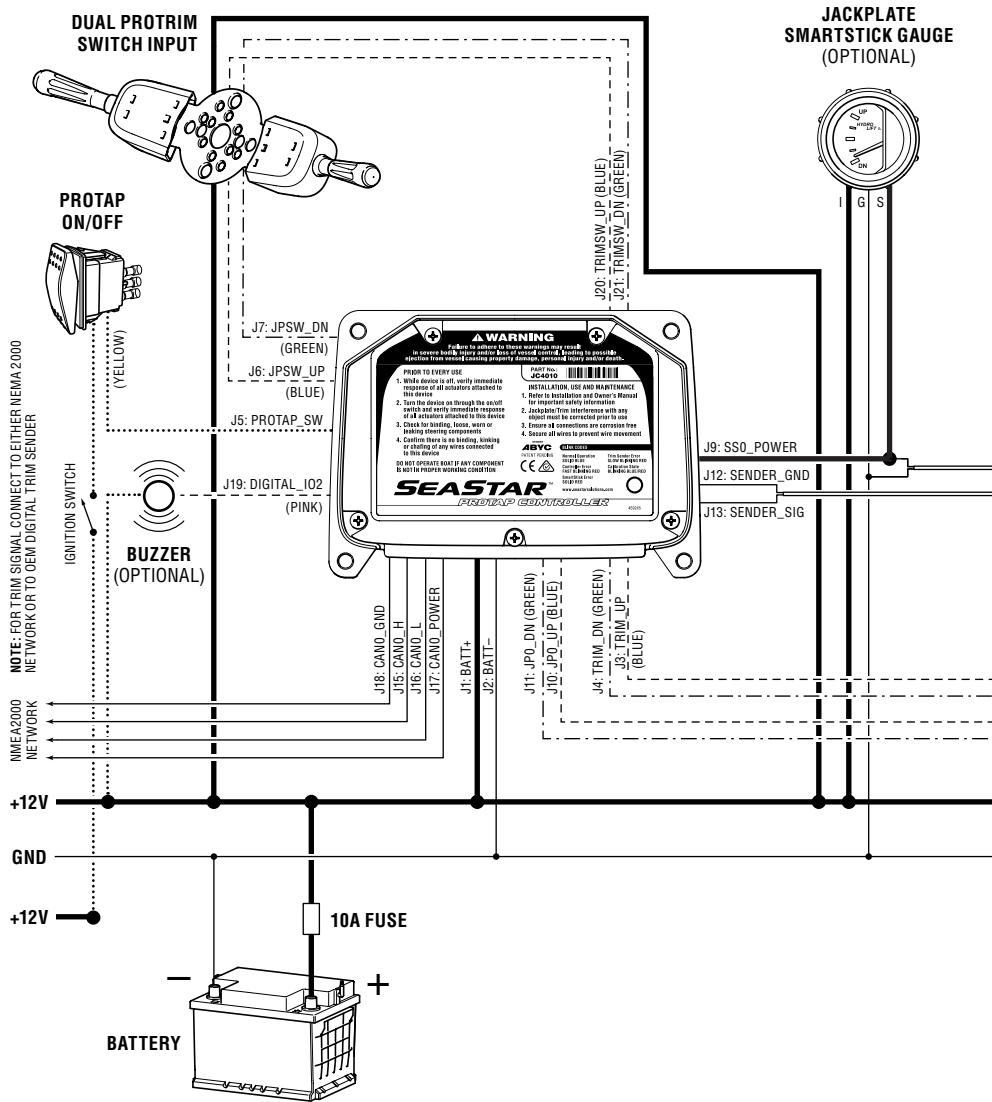
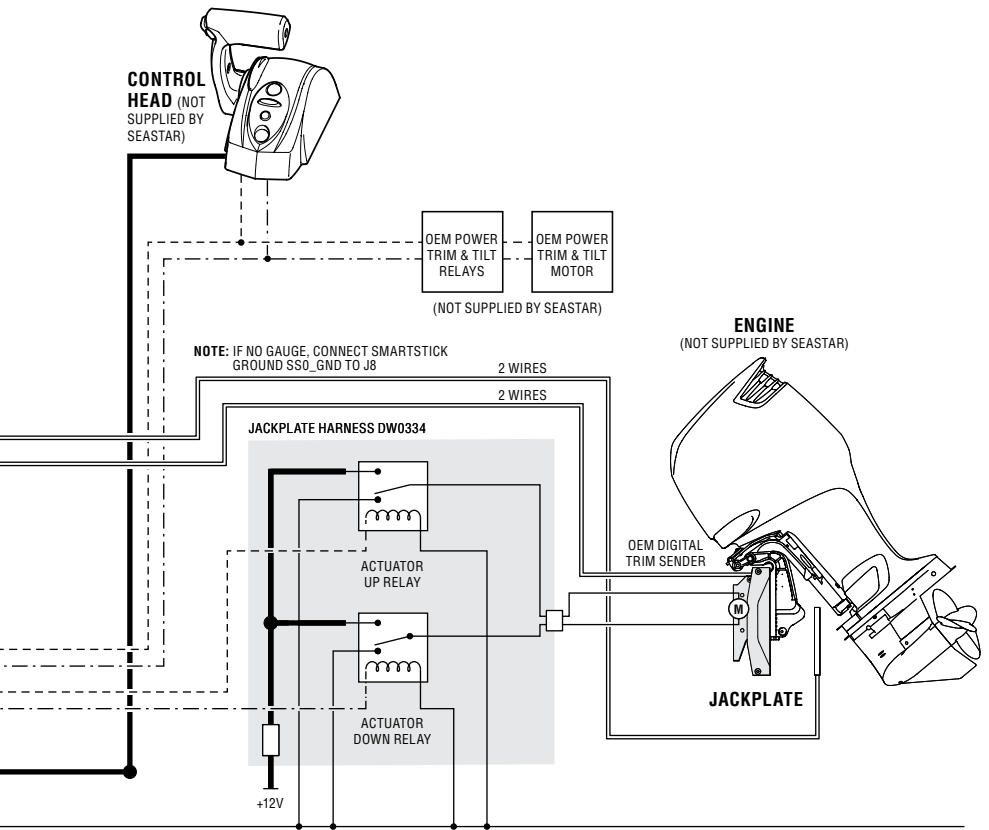

Figure 3-2. Single Jackplate, Gauge and Trim.



Referring to figure 4-1 on page 12 match the wiring in the schematic to the pin on the controller.

Twin Jackplate (Gauge Optional)

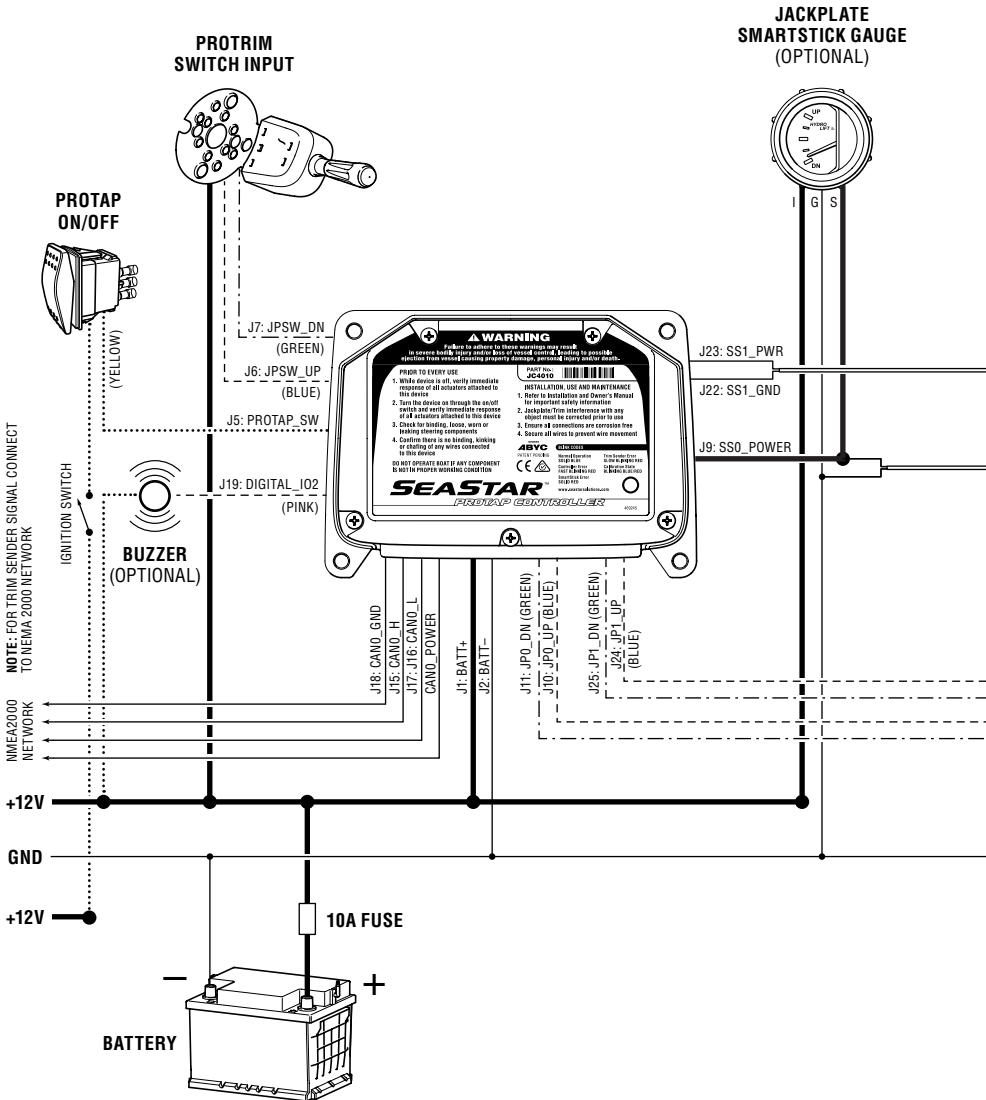
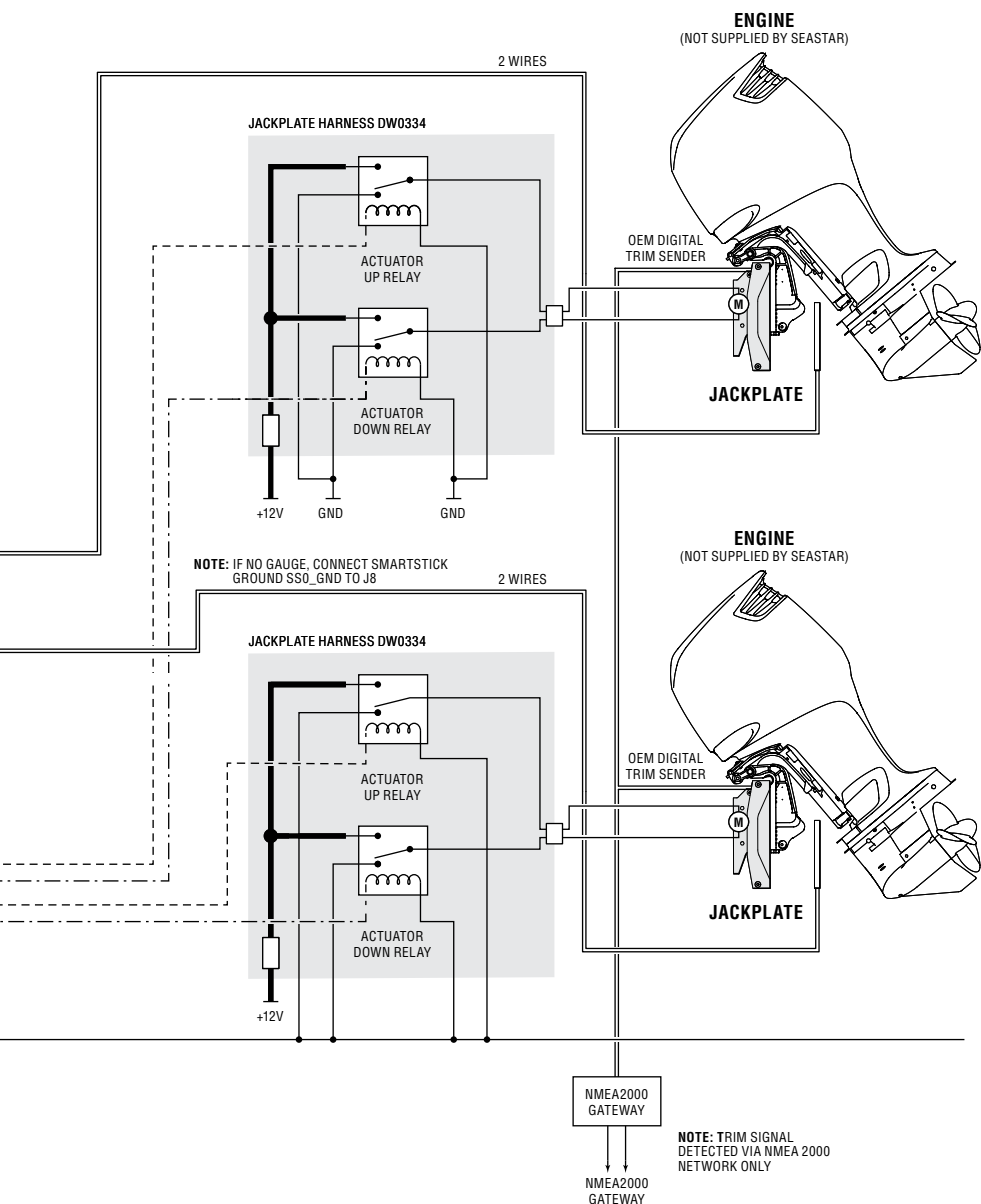

Figure 3-3. Twin Jackplate and Gauge.



Referring to figure 4-1 on page 12 match the wiring in the schematic to the pin on the controller.

4.0 INSTALLATION

4.1 WIRING

⚠ WARNING

Ensure all wires exiting the controller are strain relieved.

⚠ WARNING

Ensure all wires are exiting the controller in a downwards direction.

Use ring terminals or locking type fork terminals that are designed to safely accommodate 18 gauge wire and fit a #6 stud. Power cables attaching to J1 and J2 should use 16 gauge wire.

Recommended tightening torque:

- Terminals: 9 in-lb (1.02 Nm).

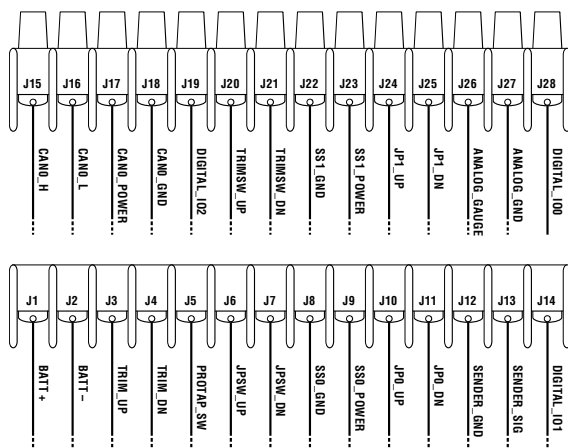

Figure 4-1. Controller Pin-Out.

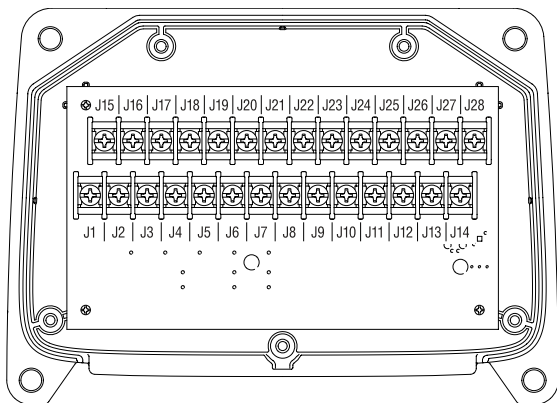

Figure 4-2. Top view of the controller with pin out.

PIN	SIGNAL NAME	DESCRIPTION
J1	BATT+	Power supply input (+) from 12V battery (red).
J2	BATT-	Power supply input (-) from 12V battery (black or yellow).
J3	TRIM_UP	Trim Up Output. Connected to engine power trim and tilt up direction (blue).
J4	TRIM_DN	Trim Down Output. Connected to engine power trim and tilt down direction (green).
J5	PROTAP_SW	ProTap Controller On/Off switch that acts as a wakeup line between Normal and Smart modes.
J6	JPSW_UP	ProTrim Jackplate Up switch input (blue).
J7	JPSW_DN	ProTrim Jackplate Down switch input (green).
J8	SS0_GND	SmartStick 0 ground line. If Jackplate Gauge is connected, this will not need to be connected (black).
J9	SS0_POWER	With Gauge Connected: Connect to the stud on the gauge labeled as "S". Without a Gauge Connected: Connect to the red wire of the SmartStick on the port Jackplate.
J10	JPO_UP	Connected to the port Jackplate up direction wire (blue).
J11	JPO_DN	Connected to the port Jackplate down direction (green).
J12	SENDER_GND	Digital trim sender input (-) from OEM device.
J13	SENDER_SIG	Digital trim sender input (+) from OEM device.
J14	DIGITAL_IO1	Pending future software release.
J15	CAN0_H	Isolated CAN High communication line from NMEA2K network (white).
J16	CAN0_L	Isolated CAN Low communication line from NMEA2K network (blue).
J17	CAN0_POWER	Isolated CAN power supply input (+) line from NMEA2K network (red).
J18	CAN0_GND	Isolated CAN power supply input (-) line from NMEA2K network (black).
J19	DIGITAL_IO2	Connection for optional external 12V buzzer. Connect the pink lead of the buzzer to this pin.
J20	TRIMSW_UP	ProTrim, Trim Up switch input (blue).
J21	TRIMSW_DN	ProTrim, Trim Down switch input (green).
J22	SS1_GND	SmartStick 1 ground line (black).
J23	SS1_POWER	SmartStick 1 position sense line (red).
J24	JP1_UP	Connected to the starboard Jackplate up direction wire (blue).
J25	JP1_DN	Connected to the starboard Jackplate down direction (green).
J26	ANALOG_GAUGE	Third party analog gauge output (+). 0-5V output based on SmartStick 0 position.
J27	ANALOG_GND	Third party analog gauge output (-).
J28	DIGITAL_IO0	Digital input to enter calibration mode and recalibrate system. Connect 12V to this line at power on to enter calibration mode.

Table 4-1.

**Direct Trim Signal
Wiring Harnesses**

Twin engines can not use a direct connection and **MUST** use NMEA 2000 harness PTK5010.

KIT NO.	DESCRIPTION	APPLICATION
PTK5010	Harness, ProTap, CAN, NMEA 2000	All engines with NMEA network gateway
PTK5020	Harness, ProTap, for Yamaha 2 wire senders	Yamaha V6 and smaller
PTK5021	Harness, ProTap, for Yamaha 3 wire senders	Yamaha V8
PTK5040*	Harness, ProTap, for Mercury Optimax/ProXs with SmartCraft	Mercury ProXs, Optimax with SmartCraft network
PTK5041	Harness, ProTap, for Mercury Verado sender	Mercury Verado

* This part number is a for a digital trim sender that is specific to the Mercury SmartCraft network.

Table 4-2. Trim signal wiring harnesses.

**Pro Trim Switch
Input**

Please refer to PT1000/PT2000 PT1000-1/PT2000-1 single/dual bezel installation instruction supplied with Pro Trim switch for installation details.

**Jackplate SmartStick
Gauge** (not supplied)

Please refer to System Diagrams in Section 3.2 for gauge installation.
ProTap can operate with a SeaStar Jackplate Gauge DW0148. This is sold separately from the ProTap controller.

External Buzzer
(not supplied)

Please refer to System Diagrams in Section 3.2 for optional buzzer installation.
The ProTap controller has an internal buzzer that, along with the diagnostic LED, notify the operator as to the system status. In addition to the internal buzzer, an external 12V buzzer may be installed should the operator require a more audible feedback from the ProTap system.

⚠ WARNING

An external buzzer is required if the ProTap controller is mounted in an area where the internal buzzer cannot be heard or is difficult to hear while the boat is underway.

This page left intentionally blank.

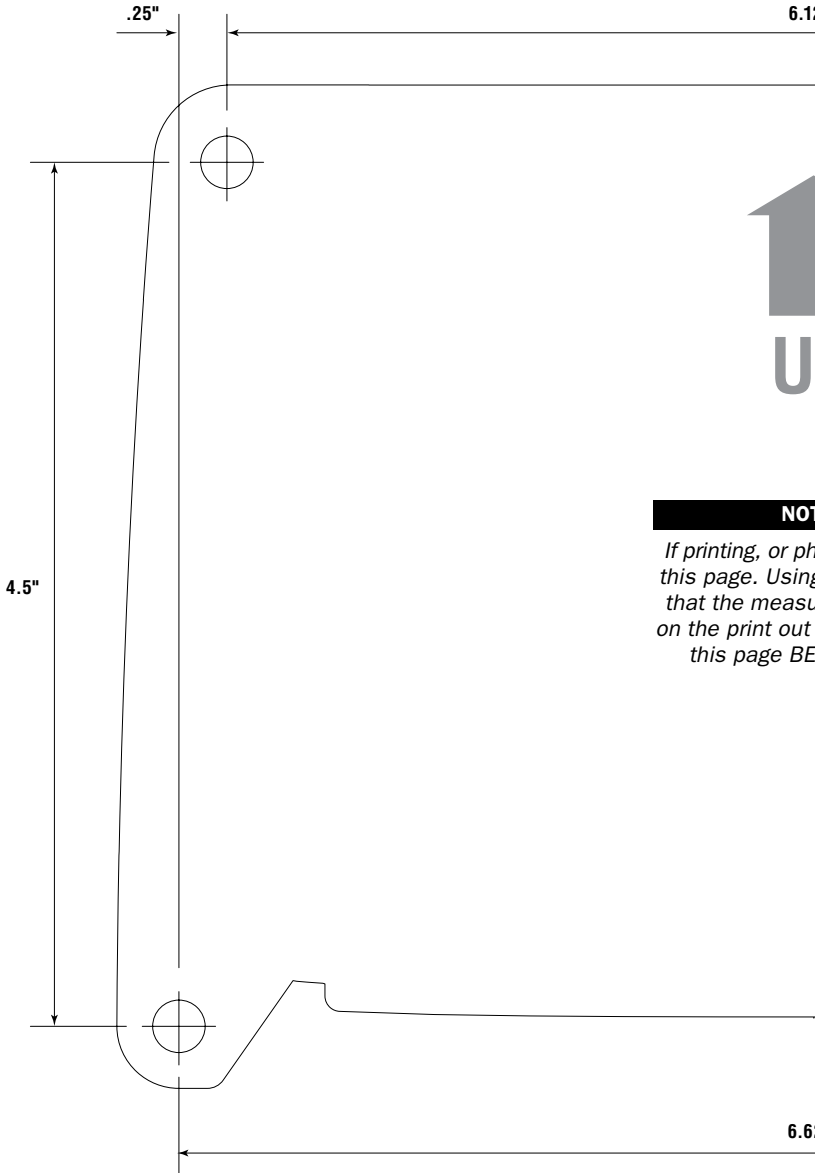

Mounting Template

25"



NOTE

*When photocopying from
this document, confirm
measurements shown
are as stated on
this page BEFORE drilling.*

25"

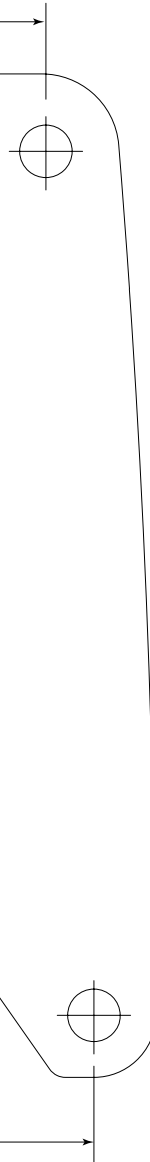

This page left intentionally blank.

Direct Trim Sender Connection

If you are connecting an analog trim sender harness it is important to locate a proper trim sender connector. Trace the wire from the trim sender in the midsection all the way to the connector. Once the trim sender T-harness is connected run the wire to the controller through the engine rigging tube.

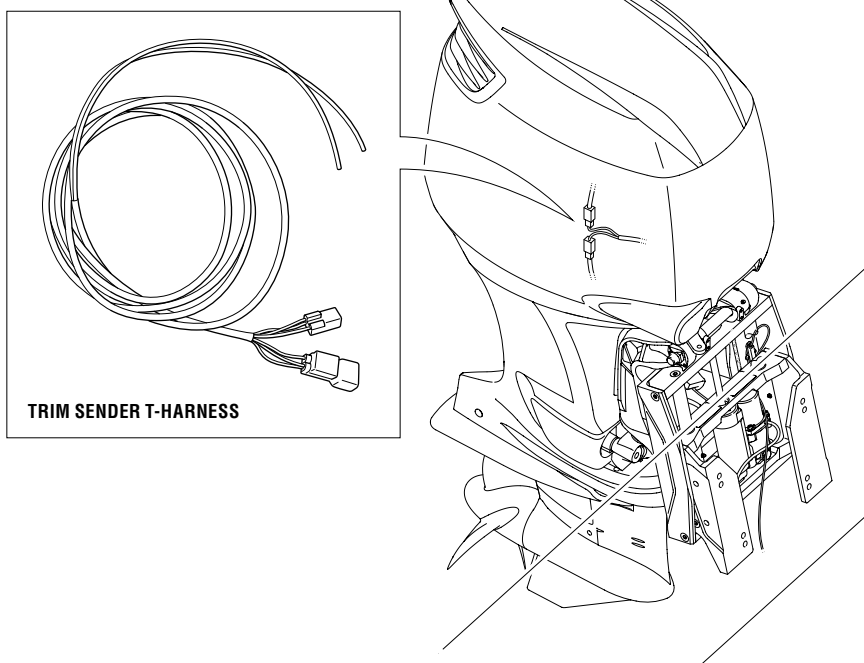

Figure 4-3. Trim Sender connection.

On/Off Switch

ProTap on/off switch MUST be connected to the ignition switch OUTPUT line only.

NOTICE

When ignition switch is off, trim signal is lost. ProTap will beep loss of trim signal fault if not wired to the ignition switch OUTPUT.

⚠ WARNING

Do not use ignition switch to turn the protap off during calibration. This will disconnect trim signal and trim positions will not be saved.

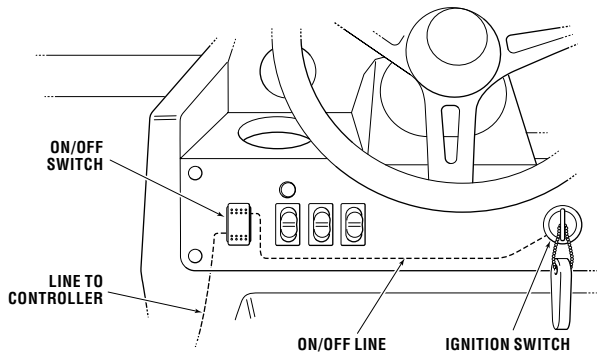

Figure 4-4.

Trim Switch Splicing

To enable trim control the controller needs to be connected to the trim switch wires on the control head.

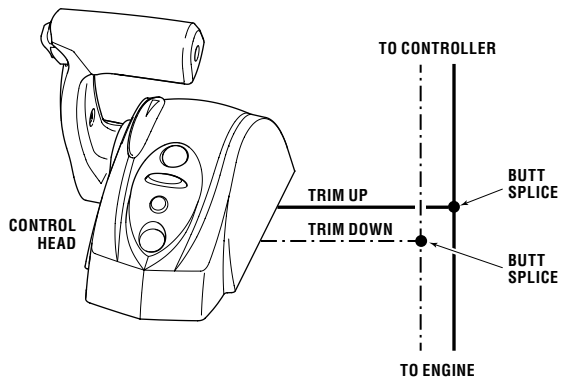

Figure 4-5. Dash Mount Control Head option.

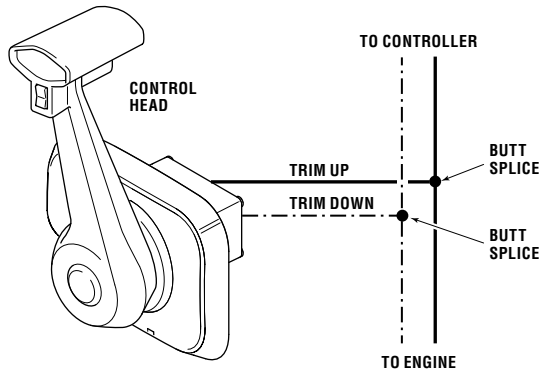

Figure 4-6. Side Mount Control Head option.

Trim Up

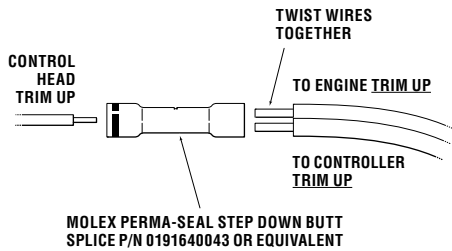

Figure 4-7.

Trim Down

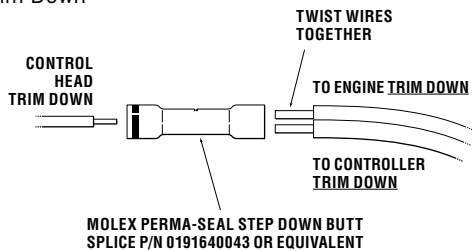

Figure 4-8.

Top Cover

Once all connections have been properly installed, secure the top cover to the ProTap controller.

Recommended tightening torque:

- Top Cover: 13 in-lb (1.5 Nm).

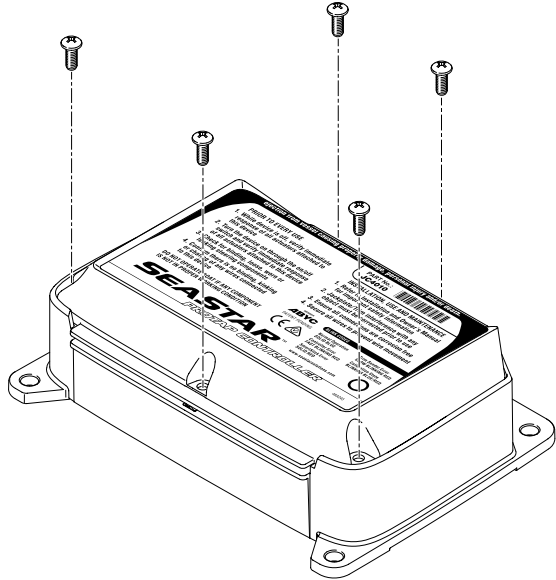

Figure 4-9.

▲ WARNING

The top cover must be properly secured to the ProTap controller while the boat is underway. Failure to do so may result in injury and/or loss of vessel control, leading to possible ejection from vessel causing property damage, personal injury and/or death.

4.2 Installation Overview

ProTap controller should be mounted in a cool dry area. Ensure that all wire leads are secured after connecting them to the controller. Use four 1/4 inch corrosion proof screws for mounting.

⚠ WARNING

All electrical connections and harness must comply with ABYC wiring standards, be rated for 105°C (221°F), and compliant with SAE-J1128.

DO

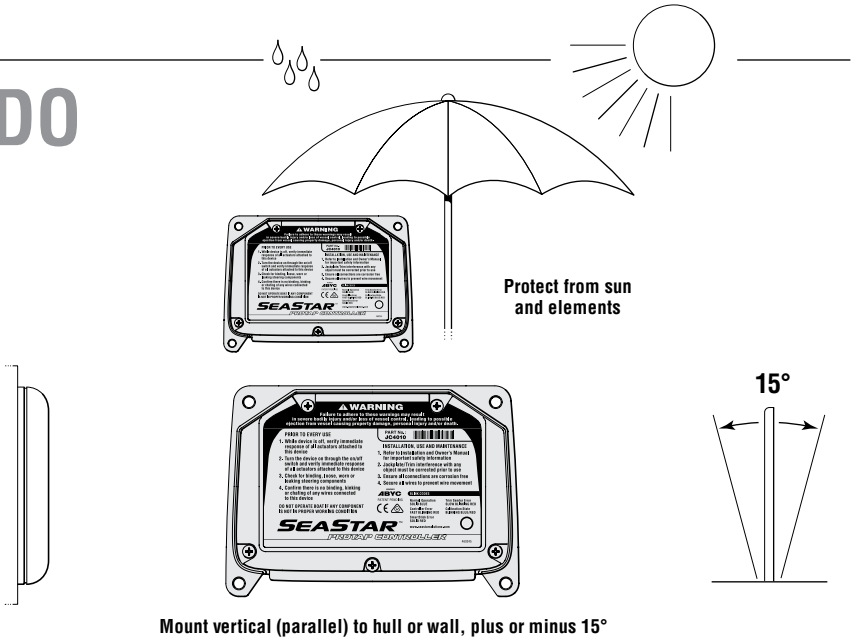

DO NOT

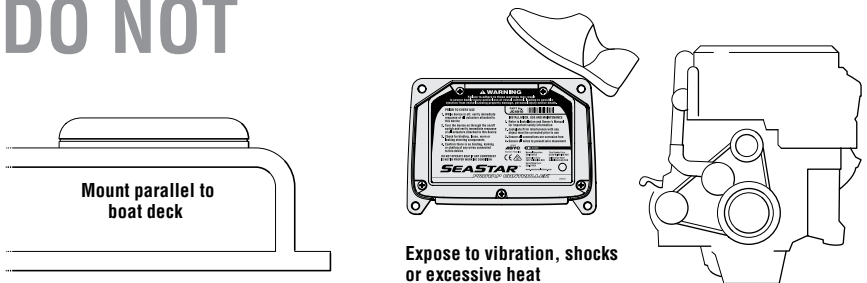

Figure 4-10.

This page left intentionally blank.

5.0 CALIBRATION PROCEDURE

NOTICE

Refer to section 7 for blink and buzzer codes during calibration.

Once the controller is properly installed and turned on for the first time, it will need to be calibrated. This will allow the controller to determine the range of Jackplate and, if connected, trim information from the engine(s). In addition, it will allow you to set a Safe position for tilt protection and a trim to tilt range threshold.

Please follow the procedure below to perform the controller calibration.

If you need to recalibrate the controller apply 12V to J28 pin before turning the controller on. This will place the controller in a calibration mode.

⚠ WARNING

If the Jackplate smartstick or trim sender is replaced at any time the system MUST be recalibrated. Failure to do so may result in injury and/or loss of vessel control, leading to possible ejection from vessel causing property damage, personal injury and/or death.

⚠ WARNING

Ensure engine is not running during calibration procedure.

⚠ WARNING

During the calibration procedure please ensure that the engine can move through the entire trim/tilt range without interference. Please note that the trim down position calibration is performed with a Jackplate in the fully up position.

NOTICE

If trim signal connected, ensure engine key is in ON position for trim sender to be powered.

1. Turn the controller on. When in calibration mode the LED will flash alternating RED/BLUE.
2. Move the Jackplate(s) to the full down position while ensuring engine(s) are in a position that will not cause any interference. Once a hard-stop is reached, continue to drive through the hard-stop for three seconds. An LED and buzzer code will indicate that the Jackplate(s) down hard-stop has been memorized.
3. Move the Jackplate(s) to the full-up position. Once a hard-stop is reached, continue to drive through the hard-stop for three seconds. An LED and buzzer code will indicate that the Jackplate(s) up hard-stop has been memorized.
4. If there is no trim information connected to ProTap, turn the controller off using the controller ON/OFF switch and exit calibration mode. If trim signal is present, proceed to step #5.

5. Move the engine(s) trim to the full-down position. Once a hard-stop is reached, double-tap the Jackplate switch down. An LED and buzzer code will indicate that the engine(s) trim down position is memorized.
6. Move the engine(s) trim/tilt to the full-up position. Once a hard-stop is reached, double-tap the Jackplate switch up. An LED and buzzer code will indicate that the engine(s) tilt up position is memorized.
7. With the engine(s) tilt in the full-up position, move the Jackplate(s) to the lowest position where no component interference is possible. This will be memorized as the Jackplate Safe position when turning controller off.
8. Trim the engine(s) down to the highest angle while still within the trim range. This will be memorized as the trim/tilt threshold when turning controller off.
9. Turn controller off using ON/OFF switch. Do not use engine key off as the trim signal will be lost and trim positions will not be memorized.
10. Turn the controller back on. When successfully calibrated the LED will be solid BLUE. Check that the "Smart" mode is operational as per Section 6.0.

 **WARNING**

If trim signal connected, during initial Tilt Protection check, tilt the engine up slowly and ensure that Tilt Protection is engaged. Failure to do so may result in damage to the vessel or engine components.

6.0 OPERATING MODES

ProTap controller is available in two operating modes, B-Mode and F-Mode. These modes are designed for different boating environments. Please see below for a detailed description of each mode and how to utilize the controller.

6.1 Bass/Bay B-Mode (Part # JC4010)

This mode is designed to get you quickly up to speed by memorizing the Jackplate and, if connected, trim position. It also allows you to fine tune both Jackplate and trim in a controlled manner by tapping the Jackplate or trim toggle switches.

Jackplate Control

- Memorize two of your favorite Jackplate positions by holding a Jackplate toggle switch up or down for more than 5 seconds.
- Recall the two memorized position by holding the Jackplate toggle switch up or down for 1-5 seconds.
- Tap the Jackplate toggle switch up or down to move the plate in controlled 1/4" increments.
- Multiple taps on the Jackplate toggle switch are memorized and plate will move the same number of increments without pausing.
- ProTap controller can control up to 2 Jackplates while making sure they are in sync with each other.

WARNING

Tilt protection not engaged when ProTap turned off.

Tilt protection not engaged if there is a loss of trim signal.

When tilting the engine, always visually check that Jackplate is up to prevent any steering or engine damage.

Trim Control

NOTICE

Trim control only available for single engine applications.

NOTICE

Trim control available in trim range only. If engine in tilt range the switch will revert to normal operation. Move engine back to trim range for Trim Control.

To enable, connect trim sender either direct or using a NMEA 2000 harness as per Table 4-2:

- Memorize two of your favorite trim positions by holding the trim toggle switch up or down for more than 5 seconds.
- Recall the two memorized trim position by holding the trim toggle switch up or down for 1-5 seconds.
- Tap the trim toggle switch up or down to move the trim in set increments of 1/20 of trim range.
- Multiple taps on the trim toggle switch are memorized and engine trim will move the same number of increments without pausing.

Tilt Protection

NOTICE

Dual engine tilt protection only available through a NMEA 2000 harness connection.

Connecting a trim sender signal direct via a harness or over NMEA 2000 network to the controller will allow you to set engine tilt protection during the initial calibration. It allows you to set the safe position and trim/tilt threshold. When engine moves to tilt range the Jackplate will move up to a Safe position.

6.2 Flats F-Mode (Part # JC4020)

This mode is designed to get the plate quickly up or down when running through a really shallow water.

Jackplate Control

- Double tap Jackplate toggle switch up to move the plate all the way up.
- Double tap Jackplate toggle switch down to move the plate all the way down.
- Single tap on the Jackplate toggle switch up or down will move the plate in 2" increments from your current position.
- Continuously holding the Jackplate toggle switch up or down will move the plate up or down during the duration the switch is engaged.
- ProTap controller can control up to 2 Jackplates while making sure they are in synch with each other.

Trim Control

NOTICE

Trim control only available for single engine applications.

NOTICE

Trim control available in trim range only. If engine in tilt range the switch will revert to normal operation. Move engine back to trim range for Trim Control.

To enable, connect trim sender either direct or using a NMEA 2000 harness as per Table 4-2:

- Memorize two of your favorite trim positions by holding the trim toggle switch up or down for more than 5 seconds.
- Recall the two memorized trim position by holding the trim toggle switch up or down for 1-5 seconds.
- Tap the trim toggle switch up or down to move the trim in set increments of 1/10 of trim range.
- Multiple taps on the trim toggle switch are memorized and engine trim will move the same number of increments without pausing.

Tilt Protection

NOTICE

Dual engine tilt protection only available through a NMEA 2000 harness connection.

Connecting a trim sender signal direct via a harness or over NMEA 2000 network to the controller will allow you to set engine tilt protection during the initial calibration. It allows you to set the safe position and trim/tilt threshold. When engine moves to tilt range the Jackplate will move up to a Safe position.

7.0 TROUBLESHOOTING

LED Codes

PROTAP STATUS	COLOUR	BLINK PERIOD	DESCRIPTION
ProTap Controller Error	Red	500ms On 500ms Off	A non-SmartStick or trim sender fault is present that is preventing the ProTap from performing at 100%.
SmartStick Error	Red	Solid Colour	Fault 0x7FDA[x] is active.
Trim Sender Error	Red	1000ms On 1000ms Off	Fault 0x7FDB[x] is active.
Calibration Hardstop Achieved	Purple	1000ms On 1000ms Off	Jackplate or Trim Hardstop achieved during calibration mode. This blink sequence will be synchronized with the buzzer for a calibration hardstop.
Calibration State Active	Red/Blue	1000ms Red 1000ms Blue	ProTap is in a calibration state.

Table 7-1. LED Codes.

Buzzer Codes

SCENARIO	NO. OF PULSES	PERIOD OF PULSE	DESCRIPTION
Danger Fault Active	Indefinite	1000ms On 1000ms Off	Provide feedback to the user of an active danger fault.
Memory Save Command Invoked	1 pulse	500ms On 500ms Off	Provide feedback to the user that a memory save command has been invoked (Jackplate or Trim).
Jackplate Calibration Hardstop Achieved	1 pulse	1000ms On 1000ms Off	Provide feedback to the user that a Jackplate hardstop has been achieved. This buzzer sequence will be synchronized with the LED for a calibration hardstop.
Trim Calibration Hardstop Achieved	2 pulses	1000ms On 1000ms Off	Provide feedback to the user that a Jackplate hardstop has been achieved. This buzzer sequence will be synchronized with the LED for a calibration hardstop.

Table 7-2. Buzzer Codes.

NOTICE

If error is reported the controller will switch to Normal mode. Only one error is reported. To clear the error turn the controller off then on. If the error is not cleared please contact SeaStar Solutions Technical Support.

8.0 WARRANTY

8.1 Statement of Limited Warranty

We warrant to the original retail purchaser that **Marine Canada Acquisition Inc. DBA SeaStar Solutions** (herein forward referred to as **SeaStar Solutions**) products have been manufactured free from defects in materials and workmanship. This warranty is effective for two years from date of purchase, excepting that where **SeaStar Solutions** products are used commercially or in any rental or income producing activity, then this warranty is limited to one year from the date of purchase.

We will provide replacement product without charge, for any **SeaStar Solutions** product meeting this warranty, which is returned (freight prepaid) within the warranty period to the dealer from whom such product were purchased, or to us at the appropriate address. In such a case **SeaStar Solutions** products found to be defective and covered by this warranty, will be replaced at **SeaStar Solutions'** option, and returned to the customer.

The above quoted statement is an extract from the complete **SeaStar Solutions** products warranty statement. A complete warranty policy is available in our **SeaStar Solutions** products catalogue.

8.2 Return Goods Procedure

Prior to returning product to **SeaStar Solutions** under warranty, please obtain a *Return Goods Authorization number* (claim number).

Be sure to label the goods with:

- a) the name and address of the sender, and
- b) the return goods authorization number (claim number)

Please address the returned goods as follows:

From U.S.A.

RGA # ?
SeaStar Solutions
c/o UPS-SCS
19308 70th Ave S.
Kent, WA 98032

From Canada

RGA # ?
SeaStar Solutions
3831 No.6 Road
Richmond, B.C.
Canada V6V 1P6

8.3 Technical Support

Phone: 604-248-3858

email: seastar@seastarsolutions.com

Hours: Monday to Friday 05:00 – 15:30 PST

Web: www.seastarsolutions.com

9.0 APPENDIX

9.1 CAN Basic Network

The NMEA 2000[®] protocol allows several types of harness. The one shown in this document is the smaller type used in pleasure boats and small vessels. The larger harness is used in shipboard applications. Any manufacturer may use their own harness but to adhere to the standard they must have an adaptor harness that allows easy connection to the approved harness. All SEASTAR SOLUTIONS CAN Bus harness meet the NMEA 2000[®] standard and will work with any other suppliers' harness that meet the NMEA 2000[®] standard.

While the NMEA 2000[®] standard allows separate wires and terminals all CAN Bus harness use the connectors shown in this manual. They are easy to install and result in a high quality, rugged, waterproof installation. The harness should never be cut and spliced.

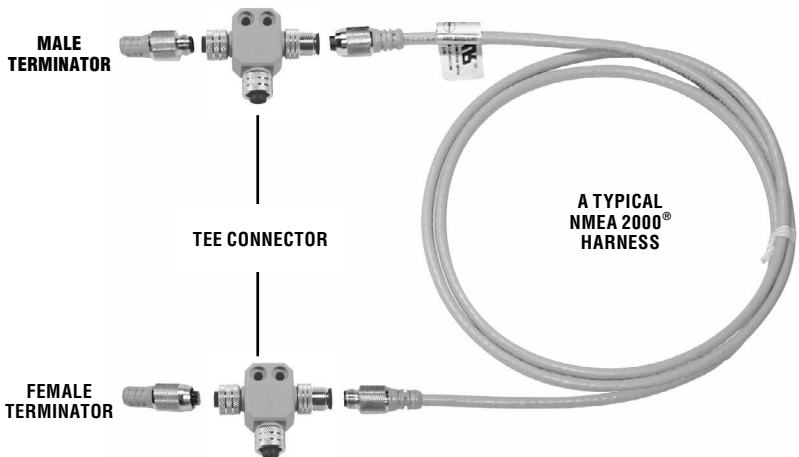

CM100XX: A typical NMEA 2000[®] harness



Figure 9-1.

CAN Bus Connectors



**CM10051:
MALE TERMINATOR**



**CM10052:
FEMALE TERMINATOR**

Figure 9-2.

Tee Connectors:

Supplied by several vendors. Appearance may vary – parts are interchangeable.

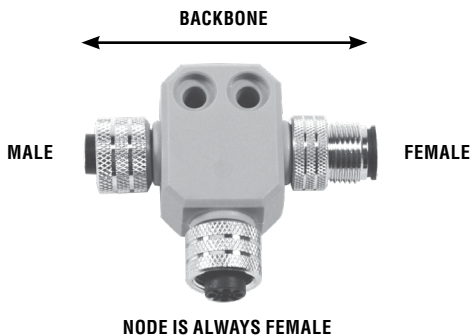

Figure 9-3.

Note regarding connectivity of tee connectors:

- When connecting a tee connector to a component always install via the middle connection (“NODE”).
- When connecting a tee connector to a CAN Bus harness to connect components that are far from each other, always install via the male/ female end of the connector (whichever applies).
- Hand-tighten after the connection is made. DO NOT tightly tie down the tee connectors, as this will create stress.

CAN Bus Connectivity

The Network must consist of a single harness run to which devices are connected by means of a tee connector. All products must connect onto the node part of the tee connector. Each end of the harness must have a terminator. It is essential there be a total of two, and ONLY two, terminators - one located at each end of the backbone.

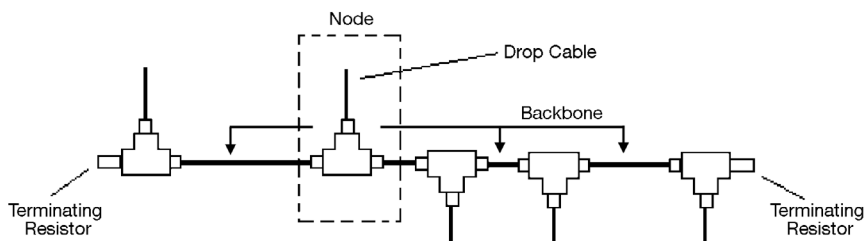

Figure 9-4.

Note: a tee connector with nothing attached to its node is OK and will not effect the network. NEVER use a terminator to cap the node of an unused tee connector.

Electrical Harness

The cabling that is used conforms to the DeviceNet standard and was developed for Industrial applications. In general the harness are molded and the connection area is sealed with o-ring gaskets to provide a good seal from the environment. The harness are available in a variety of lengths.

NOTICE

The electrical harness must not be cut or spliced. Replace worn or frayed harness.

When securing the harness and especially when tying down a number of direct connected tees never pull them down so tight as to cause strain or put a curve in the tees as this may cause a failure.

When installing a NMEA 2000® CAN Bus system there are several things to keep in mind:

- The harness ends are male and female. To avoid a mismatch it is best to work from one end toward the other. If you must work from both ends toward the middle assure that the mating point will be a male/female connection.

- It is wise to plan for expansion. With so many new NMEA 2000® products entering the market and the ability to connect on to the bus for testing it is sometimes wise to use two harness where one would suffice. The connection of the two harness can later be separated so additional tees can be inserted to add another product or test equipment.
- On 24 volt systems, a DC to DC converter or separate 12 volt battery is required.

Powering the Bus

The CAN Bus requires DC power. The voltage range is 9 to 16 volts. The power may be supplied by one or more of the products on the Data Bus or from a separate source. Most equipment manufacturers strongly recommends that at least two independent sources are used to supply the data bus power.

CAN Bus Power

The CAN Bus is used to supply power to all the items that are connected on the bus. For items drawing less than one amp, not having any other power connection, or another path back to ground the entire power for the item may be pulled from the CAN Bus. This requires the CAN Bus to have adequate sources of power.

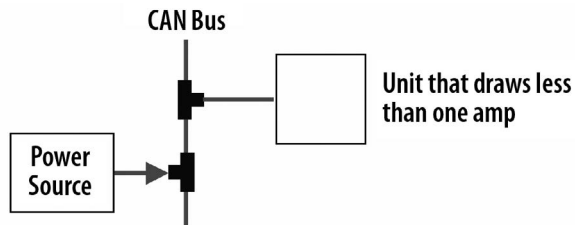

Figure 9-5.



SEASTAR SOLUTIONS
3831 NO.6 ROAD
RICHMOND, B.C.
CANADA V6V 1P6

FAX 604-270-7172

www.seastarsolutions.com

ISO 10592



© 2017 MARINE CANADA ACQUISITION INC.
DBA SEASTAR SOLUTIONS

PRINTED IN CANADA 02/18

Please scan
this QR code
and watch our
latest **Boating
Safety** video.



FORM NO. 469281 REV. F

