

MEMBER
ABYC
Setting Standards for Safer Boating



66

SIXTY SIX
ISO 9001

OPTIMUS EPS
BY SEASTAR

BAYSTAR™

SEASTAR™

INSTALLATION INSTRUCTIONS

AND USER'S MANUAL

www.seastarsolutions.com



GPS Anchor Positioning System



*Before you do it your way,
please try it our way*

©2016 SeaStar Solutions.

All Rights Reserved. This document, subject matter and all information herein is the sole, exclusive and confidential property of SeaStar Solutions and shall not be disclosed, copied, reproduced or used in whole or in part for any purpose other than as specifically authorized in writing by Marine Canada Acquisition (DBA SEASTAR SOLUTIONS).

All information, illustrations and specifications in this manual are based on the latest information available at the time of publishing. The illustrations used in this manual are intended as representative reference views only. Moreover, because of our continuous product improvement policy, we may modify information, illustrations and/or specifications to explain and/or exemplify a product, service or maintenance improvement. We reserve the right to make any change at any time without notice.



is a registered trademark of the American Boat & Yacht Council (<http://www.abycinc.org>)

NMEA2000® is a registered trademark of the National Marine Electronics Association.

Optimus, Optimus EPS, Optimus 360, SeaStar, and BayStar are all trademarks of SeaStar Solutions.

**California
Proposition 65 Warning**

Battery posts, terminals, and related accessories contain lead and lead compounds, chemicals known to the state of California to cause cancer and reproductive harm.

Wash hands after handling.

Thank you for choosing Optimus™ SeaStation by SeaStar Solutions. SeaStation is an automatic vessel positioning system that will ease and improve your boating experience.

About this Book

This manual serves as both an installation and user's manual for Optimus SeaStation. It contains the information you need to install and safely operate SeaStation. It must remain on the boat.

Notice to the Installer & Operator/User

Throughout this publication, Dangers, Warnings and Cautions (accompanied by the International Hazard Symbol ) are used to alert the user to special instructions concerning a particular service or operation that may be hazardous if ignored or performed incorrectly or carelessly. **Observe them carefully!**

These safety alerts alone cannot eliminate the hazards that they signal. Strict compliance with these special instructions during installation, operation, and maintenance, plus common sense operation, are important measures to prevent accidents.

Failure to adhere to these notices may lead to propeller injuries causing severe bodily injury and/or death.

DANGER

IMMEDIATE HAZARDS WHICH, IF NOT ACTED UPON, WILL RESULT IN SEVERE PERSONAL INJURY OR DEATH.

WARNING

HAZARDS OR UNSAFE PRACTICES WHICH, IF NOT ACTED UPON, COULD RESULT IN SEVERE PERSONAL INJURY OR DEATH.

CAUTION

Hazards or unsafe practices which could result in minor injury or product or property damage.

NOTICE

Information which is important to proper use or maintenance, but is not hazard-related.

ABBREVIATIONS

The following abbreviations are used in this manual:

ABYC	American Boat & Yacht Council
CAN	Controller Area Network
EPS	Electronic Power Steering
GPS	Global Positioning System
NMEA	National Marine Electronics Association
NMEA 2000®	A protocol for digital communication on a CAN Bus
PCM	Pump Control Module
RPM	Revolutions Per Minute
SBAS	Satellite-Based Augmentation System
STBD	Starboard (right)

Note: Some abbreviations not listed here may be found in their respective sections.

INDEX

Abbreviations	ii
1.0 Safety Information	1-1
1.1 Safety Labels	1-3
2.0 Installation	2-1
2.1 Overview.....	2-1
2.2 Before You Begin.....	2-1
2.3 Contents.....	2-1
2.4 Installing the GPS.....	2-2
2.4.1 Mounting Location	2-2
2.4.2 Mounting Alignment	2-3
2.5 Mounting Options	2-4
2.5.1 Mounting Options	2-4
2.5.2 Cable Considerations.....	2-5
2.5.3 Flush Mount.....	2-6
2.5.4 Pole Mount	2-7
2.6 Electrical Connection	2-9
2.7 Enabling SeaStation	2-9
2.8 Commissioning	2-11
2.8.1 Tuning	2-11
2.8.2 Settings.....	2-12
2.8.3 Sea Trial	2-12
2.9 Troubleshooting Guide	2-15
3.0 User	3-1
3.1 Overview.....	3-1
3.2 SeaStation Operation	3-1
3.2.1 SeaStation Modes.....	3-1
3.2.2 How to Engage and Disengage SeaStation	3-2
3.2.3 Standby Mode.....	3-3
3.2.4 Heading Bump.....	3-4
3.3 Station Transfer	3-4
3.4 SeaStation Tips.....	3-5
3.5 SeaStation Faults.....	3-5
3.5.1 Drift Faults.....	3-5
3.5.2 GPS-Compass Faults	3-6
3.6 Maintenance and Replacement Parts.....	3-7
3.6.1 Owner(s) (End Users).....	3-7
3.6.2 Qualified Marine Mechanic	3-7
3.6.3 Replacement Parts	3-7
4.0 Warranty	4-1
4.1 Statement of Limited Warranty	4-1
4.2 Return Goods Procedure	4-1

This page left intentionally blank.

1.0 SAFETY INFORMATION

WARNING

THE SAFETY INFORMATION PROVIDED BELOW IS INTENDED TO INFORM YOU OF THE DANGERS THAT MAY BE PRESENT BEFORE, DURING AND AFTER USE. IT IS CRITICAL THAT YOU READ AND UNDERSTAND ALL THE POINTS NOTED.

WARNING

THE OPTIMUS SEASTATION SYSTEM MUST ONLY BE INSTALLED BY AN AUTHORIZED DEALER OR BOAT BUILDER.

Safe operation of the SeaStation system depends upon proper installation and maintenance of the system, and the common sense, safe judgment, knowledge, and expertise of the operator. Every installer and operator of SeaStation should know the following requirements before installing or operating.

If you have any questions regarding any of these warnings, contact SeaStar Solutions.

To reduce the risk of severe injury or death:

- 1.** Always wear a Coast Guard Approved personal flotation device (PFD) and use an engine shut-off cord (lanyard).
- 2.** Engaging SeaStation causes propellers to turn automatically. This could injure someone in the water. It is the operator's responsibility to make sure no one is in the water or enters the water. If someone enters the water, pull all engine lanyard(s).
- 3.** Read and understand this User's manual and the Quick Reference Card provided with your vessel control components.
- 4.** SeaStar and Optimus components are highly engineered and safety tested to ensure system integrity. DO NOT substitute any component. Substitution with non-SeaStar or non-Optimus components may compromise system safety, performance, and reliability.

Prior to every use

Perform a system inspection as outlined below. Refer to Section 9.1 in the Optimus EPS Installation Manual (Book 50) for further details.

- 1.** Check steering fluid level in all steering pumps.
- 2.** Verify immediate steering response when turning steering wheel(s).
- 3.** Inspect all steering hoses, fittings, mechanical cables, and electrical harnesses for wear, kinks, or leaks.
- 4.** Check for binding, loose, worn or leaking steering or shift/throttle control components.
- 5.** Verify proper shift and throttle response for all control handles.
- 6.** Take control with the joystick and verify that steering, shift and throttle respond to joystick movement.
- 7.** Verify that no alarms or warnings are shown on the CANtrak display.

WARNING

DO NOT OPERATE BOAT IF ANY COMPONENT IS NOT IN PROPER WORKING CONDITION.

1.0 Safety information (continued)

During use

1. WEAR A COAST GUARD-APPROVED PERSONAL FLOTATION DEVICE (PFD).
 2. Attach engine shut-off cord (lanyard) to your PFD.
 3. Never allow anyone not familiar with the operation of the vessel control system to operate the boat at ANY time.
 4. Know and adhere to all applicable federal, state, and municipal laws and regulations that govern boating in your area.
-

WARNING

DO NOT OPERATE BOAT IF ANY COMPONENT IS NOT IN PROPER WORKING CONDITION.

WARNING

DO NOT OPERATE THE VESSEL WITHOUT A FUNCTIONING CANTRAK DISPLAY.

After use

Rinse off the SmartCylinders thoroughly, using only fresh, clean water. (Outboard-powered vessels only.)

DO NOT rinse the PCM, pumps, actuators, or any other component of the Optimus system.

DO NOT use acetone, or cleaners containing ammonia, acids, or any other corrosive ingredients on any Optimus components.

Maintenance

Refer to your Optimus 360 manual for maintenance instructions.

Keep our waters clean for all current and future users. Dispose of all fluids in accordance with your local regulations.

1.1 Safety Labels

⚠ WARNING
FAILURE TO INSTALL DECALS AT ALL BOARDING POINTS MAY LEAD TO PROPELLER INJURIES CAUSING SEVERE BODILY INJURY AND/OR DEATH.

⚠ WARNING PROPELLER INJURY HAZARD!
ONLY ENTER THE WATER WITH THE CAPTAIN'S PERMISSION
Failure to adhere to this warning may result in severe bodily injury and/or death.



This boat is equipped with **SeaStation**, an automatic boat positioning system.

When **SeaStation** is engaged:

- **PROPELLERS TURN AUTOMATICALLY**
This could injure someone in the water
- The boat will suddenly move in any direction
- It is **NOT SAFE** to be in the water near the boat
- **DO NOT** enter the water or position yourself where you could fall in to the water due to sudden boat movement

929500

Figure 1-1. Decal PID# 929500.

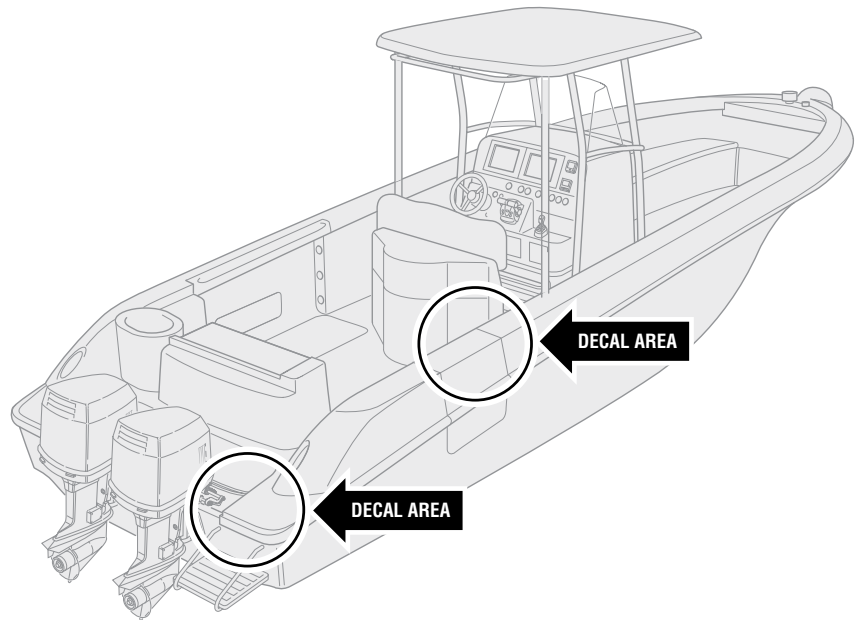

Figure 1-2. Example of decal placement on vessel.

⚠ WARNING
IF A DECAL IS MISSING OR BECOMES ILLEGIBLE, IT MUST BE REPLACED BEFORE ENGAGING SEASTATION. CONTACT SEASTAR TECHNICAL SUPPORT FOR MORE COPIES FREE OF CHARGE.

This kit contains three copies of a decal alerting swimmers that this boat is equipped with an automatic boat positioning system and that propellers will turn without warning. **A decal must be placed in a clearly visible area at EVERY boarding access point to the vessel.** This includes the transom swim-grid as well as any side doors or alternative boarding points.

If you have any questions or if you require additional decals, please contact SeaStar Solutions Technical Support by:

Email: seastar@seastarsolutions.com
Phone: 604-248-3858
Web: www.seastarsolutions.com

This page left intentionally blank.

2.0 INSTALLATION

2.1 Overview

SeaStation is an automatic vessel positioning system. SeaStation builds off of an Optimus 360 system by adding a GPS and heading sensor. The system uses position and heading data to automatically position the vessel through shift, throttle, and rudder controls.

Once your Optimus 360 system is installed, adding SeaStation is simple:

- 1.** Place warning decal(s)
- 2.** Install the SeaStation Sensor
- 3.** Route CAN2 cable from sensor to Optimus CAN2 backbone
- 4.** Apply SeaStation license provided with kit (captured on back cover of this booklet)
- 5.** Tuning for best performance

2.2 Before You Begin

Before installing SeaStation:

- 1.** Optimus 360 must be fully installed and commissioned.
- 2.** All software must be up to date – See book 65 for instructions on updating software.

2.3 Contents

- 1.** 682175 - SeaStation Installation and Users Manual
- 2.** 682176 - SeaStation Quick Reference Card
- 3.** 929500 x 3 - SeaStation warning decal
- 4.** CM10020 - 20' CAN M/F drop cable
- 5.** CM10001 - 1' CAN M/F drop cable
- 6.** CM10060 - Single port CAN tee
- 7.** 214642 - SeaStation Sensor

2.4 Installing the GPS

2.4.1 Mounting Location

This section provides information on determining the best location for the sensor.

NOTICE

The sensor should be mounted as low as possible while still maintaining good sky visibility. This will reduce false movement due to the boat rocking back and forth.

GPS Reception

When considering where to mount the sensor, consider the following GPS reception recommendations:

- Ensure there is a clear view of the sky available to the sensor so the GPS and SBAS satellites are not masked by obstructions that may reduce system performance.
- Mount the sensor as close to the center of the vessel as possible. This includes both the fore-aft direction and the port-starboard direction.
- Locate any transmitting antennas away from the sensor by at least several feet to ensure tracking performance is not compromised, giving you the best performance possible.
- Make sure there is enough cable length to tie into the Optimus CAN2 backbone of the vessel.
- Do not locate the antenna where environmental conditions exceed those specified in the table 2-1 Environmental Conditions below.

Environmental Considerations

The sensor is designed to withstand harsh environmental conditions; however, adhere to the following limits when storing and using the sensor:

Item	Specification
Operating Temperature	-30°C to +70°C (-22°F to +158°F)
Storage Temperature	-40°C to +85°C (-40°F to +185°F)
Humidity	100% non-condensing

Table 2-1. Environmental Conditions.

VHF Interference

VHF interference from devices such as cellular phones and radio transmitters may interfere with GPS operation. For example, if installing the sensor near marine radios consider the following:

- VHF radios can interfere with GPS signals.
- Follow VHF radio manufacturers' recommendations on how to mount their radios and what devices to keep a safe distance away.

Before installing the sensor use the following diagram to ensure there are no nearby devices that may cause VHF interference.

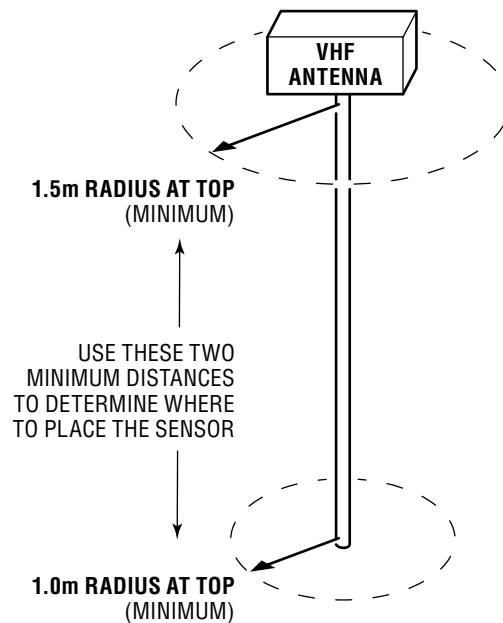

Figure 2-1. Sensor mounting distance from nearby VHF radios.

2.4.2 Mounting Alignment

The SeaStation sensor should be mounted parallel to, and along the centerline of, the axis of the boat. The bottom of the sensor has an arrow - the arrow must point forward.

The top of the sensor enclosure incorporates sight design features to help align the sensor with respect to a centered feature on your vessel, such as the bow.

To use the sights, look through the medallion in the center of the enclosure such that the sighting post is centered, as shown in figure 2-2. Adjust the sensor until the vessel's centered feature is in line with the medallion channel and the center post.

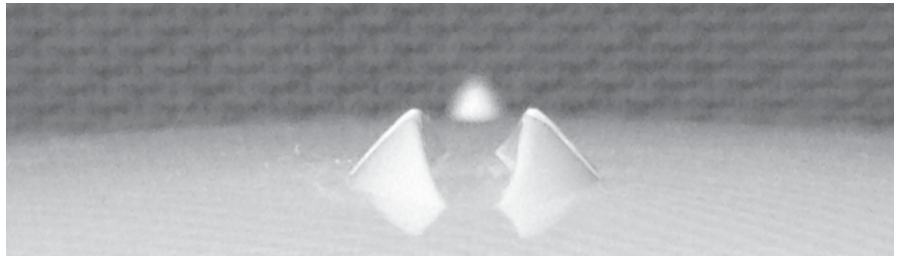

Figure 2-2. Long site alignment channel

2.5 Mounting Options

2.5.1 Mounting Options

This section provides information on determining the best location for the SeaStation sensor.

The sensor allows for both pole or flush mounting. Follow directions below for detailed mounting directions.

SeaStation Sensor Dimensions

Figure 2-3 and figure 2-4 illustrates the physical dimensions of the sensor.

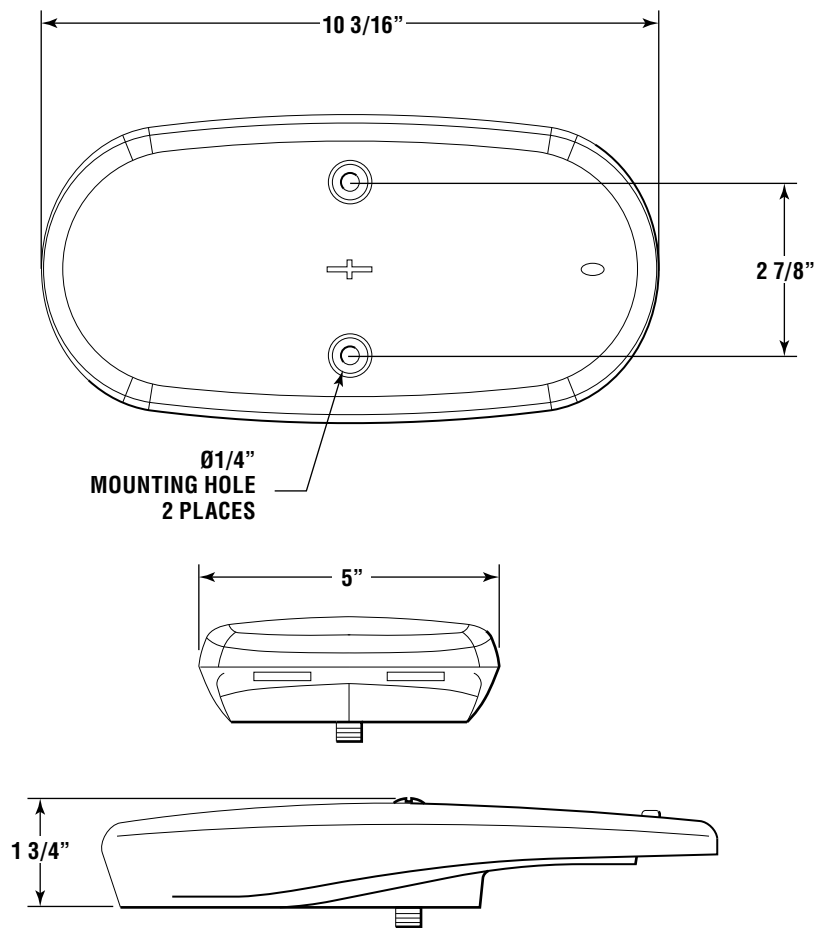

Figure 2-3. Sensor dimensions

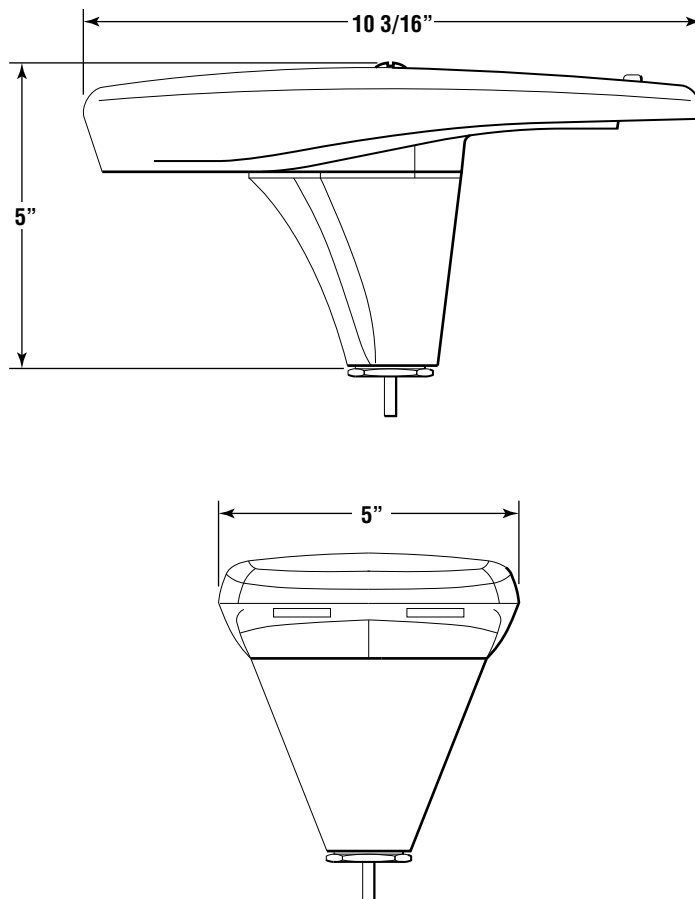

Figure 2-4 : SeaStation sensor dimensions with adapter

2.5.2 Cable Considerations

Before mounting the sensor, consider the following regarding cable routing:

⚠ WARNING
IMPROPERLY INSTALLED
CABLE NEAR MACHINERY
CAN BE DANGEROUS

- Avoid running the cable in areas of excessive heat
- Keep cable away from corrosive chemicals
- Do not run the cable through door or window jams
- Keep cable away from rotating machinery
- Do not crimp or excessively bend the cable
- Avoid placing tension on the cable
- Remove unwanted slack from the cable at the sensor end
- Secure along the cable route using plastic tie wraps

2.5.3 Flush Mount

The bottom of the SeaStation sensor contains two holes for flush mounting the unit to a flat surface (figure 2-5). The flat surface may be something you fabricate per your installation, an off-the-shelf item (such as a radar mounting plate), or an existing surface on your vessel.

NOTICE

SeaStar Solutions does not supply the mounting surface hardware. You must supply the appropriate fastening hardware required to complete the installation of the sensor.

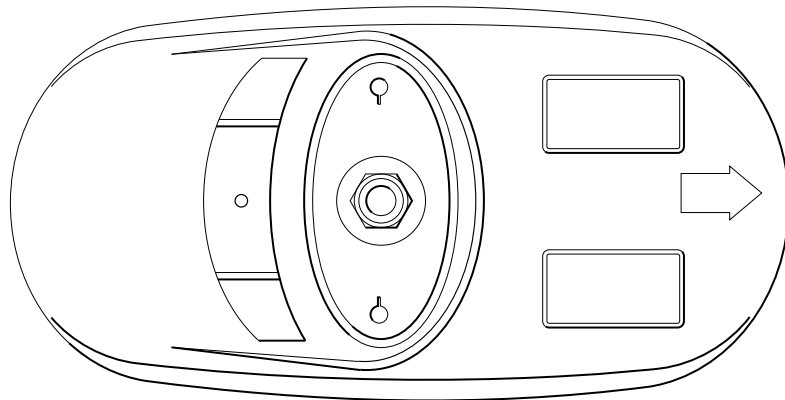

Figure 2-5: Flush mounting with holes in the SeaStation sensor

Before flush mounting the sensor

- Choose a location that meets the mounting location requirements.
- Using the fixed base as a template, mark and drill the mounting holes as necessary for the mounting surface.

⚠ WARNING

WHEN INSTALLING THE SENSOR, HAND TIGHTEN ONLY. DAMAGE RESULTING FROM OVER-TIGHTENING IS NOT COVERED BY THE WARRANTY.

Flush mounting the sensor

1. Mark the mounting hole centers and connector center on the mounting surface.
2. Place the sensor over the marks to ensure the planned hole centers align with the true hole centers (adjusting as necessary).
3. Use a center punch to mark the hole centers.
4. Drill the mounting holes to a diameter of 1/4" appropriate for the surface.
5. Drill the connector hole to a diameter of 1-1/8" appropriate for the surface.
6. Pull the cable through the center connector hole and attach the cable directly to the sensor, ensuring the connector is fastened securely to the unit.
7. Place the sensor over the mounting holes and insert the mounting screws through the top of the sensor and through the mounting surface.
8. Use two M6 washers and M6 nuts to secure the sensor to the mounting plate (washers and nuts not included).

2.5.4 Pole Mount

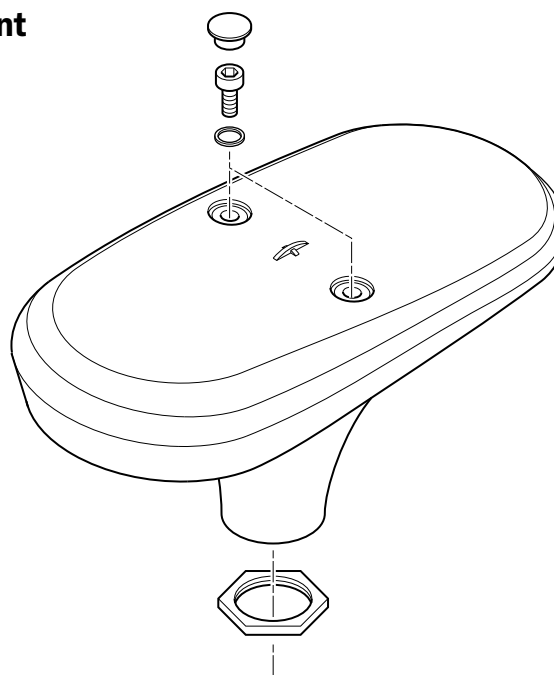

Figure 2-6: Sensor, with adapter

Before pole mounting the sensor

- Choose a location that meets the mounting location requirements.
- Mark and drill the mounting holes as necessary for the threaded pole.

Pole mounting instructions for sensor (Inside Pole)

Required tools: 5 mm Allen key for M6 screws and adjustable wrench to tighten jam nut.

1. Insert mating cable through both the jam nut and 1" mounting adapter base.
2. Place the jam nut on the pole followed by the 1" adapter base. Hand tighten the base to the desired orientation.
3. Adjust the jam nut to secure the orientation.
4. Connect the mating end of the cable to the sensor connector located on the bottom of the unit.
5. Insert the base adapter into sensor by placing the tongue of the base into the groove of the sensor unit. When the tongue is properly seated in the groove, the rest of the base can be pressed into place to create a smooth seam between the base and sensor unit.
6. Use 5 mm Allen key to fasten two M6 screws to secure sensor onto adapter. Use 15 in-lb torque.
7. Insert each O-ring onto a plastic cap.

WARNING

OVER-TIGHTENING MAY DAMAGE THE SYSTEM. THIS IS NOT COVERED UNDER WARRANTY.

8. Install plastic cap with O-ring onto sensor unit (rectangular notch faced towards the outside).
9. Align and set the direction of sensor unit, while using the jam nut to secure the unit (hand-tighten).

Pole mounting instructions for sensor (Outside Pole)

Required tools: 5 mm Allen key for M6 screws and adjustable wrench to tighten jam nut

1. Place the jam nut on the pole followed by the 1" adapter base. Hand tighten the base to the desired orientation.
2. Adjust the jam nut to secure the orientation.
3. Run the cable throughout the vessel making sure to leave enough slack to mate the CAN cable to both the Optimus CAN2 and the sensor unit.
4. Run the CAN cable through the opening in the side of the pole mounting adapter. And then connect the mating end of the cable to the sensor connector located on the bottom of the unit.
5. Insert the base adapter into sensor by placing the tongue of the base into the groove of the sensor unit. When the tongue is properly seated in the groove, the rest of the base can be pressed into place to create a smooth seam between the base and sensor unit.
6. Use 5 mm Allen key to fasten two M6 screws to secure sensor onto adapter. Use 15 in-lb torque.
7. Insert each O-ring onto a plastic cap.
8. Install plastic cap with O-ring onto sensor unit (rectangular notch faced towards the outside).
9. Align and set the direction of sensor unit, while using the jam nut to secure the unit (hand-tighten).

**WARNING**

OVER-TIGHTENING MAY DAMAGE THE SYSTEM. THIS IS NOT COVERED UNDER WARRANTY.

2.6 Electrical Connection

The SeaStation sensor connects to the Optimus CAN 2 backbone. The installation kit comes with a 20 foot CAN 2 cable, a 1 foot CAN 2 cable and a tee connector. If the CAN 2 hub in the Optimus 360 installation is full, remove the terminator and connect the 1 foot CAN 2 cable in its place. Install the tee connector at the opposite end of the 1 foot cable and reinstall the terminator on the tee. The 20 foot cable can now be routed from the tee connector up to the SeaStation sensor.

If the 20 foot CAN 2 cable is not long enough to reach from the CAN 2 hub to the SeaStation sensor, a longer cable (CM10030) must be ordered separately. In this case the 30 foot cable must be connected directly to the hub and the tee, and the terminator and 1 foot cable are connected at the SeaStation sensor end of the 30 foot cable.

2.7 Enabling SeaStation

SeaStation requires a license code that is specific to each installation. A copy of the license is fixed to the back of your original manual as well as to the bottom of your SeaStation sensor.

The license key must be entered in the CANtrak display to enable SeaStation. Follow these steps:

1. Using the CANtrak, navigate to **Dealer Menu > Initial Setup > SeaStation > Enter New License Code**.

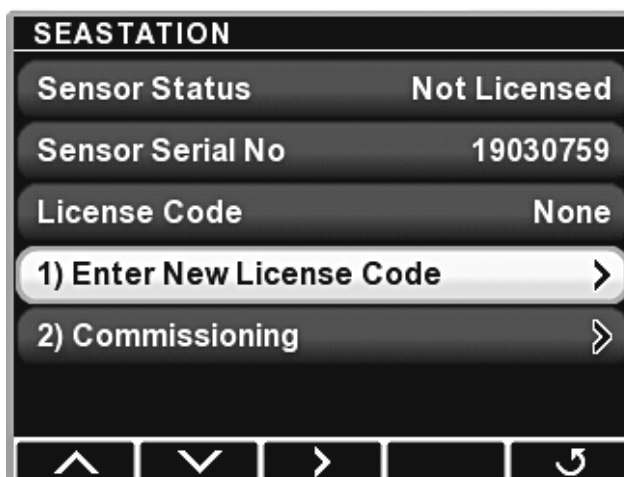

Figure 2-7.

2. Enter the license code (captured on back cover of this booklet).
3. Make sure the new license code is correct and press OK to confirm.



Figure 2-8.

4. Check that the **Sensor Status** has changed to **Licensed**. If it has not, retry entering the license code.

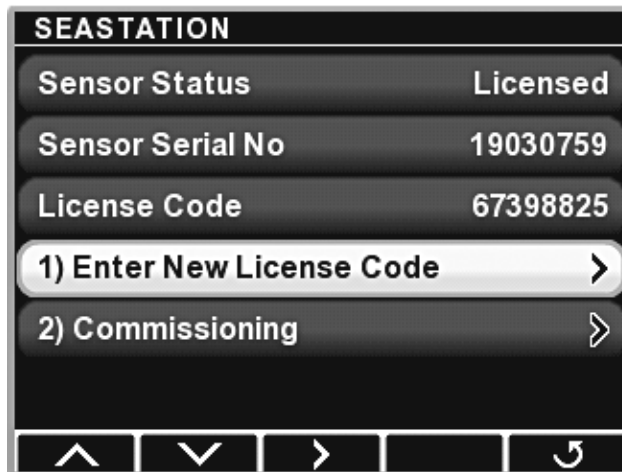

Figure 2-9.

2.8 Commissioning

2.8.1 Tuning

NOTICE

These steps are optional in Book 65 (Joystick Tuning section) but are required for all SeaStation systems, and must be retuned when upgrading an existing Optimus 360 system from Rev J CANtrak software (Spring 2016) or earlier.

NOTICE

*The **Normal** and **Boost** tuning values seen right and on the following pages do not need to be retuned – only the **Off-Idle** values.*

The key to good SeaStation performance is a well tuned joystick. SeaStation usually operates at low RPMs so emphasis needs to be put on tuning the joystick at its “Off-Idle” position. There are three steps:

1. Balance rotation power **Off-Idle REV/FWD Ratio**
2. Tune **Off-Idle Rudder Angle**
3. Balance sideways power **Off-Idle REV/FWD Ratio**

STEP 1

1. Bring the boat to a stop with boost mode off.
2. Navigate to **Dealer Menu > Initial Setup > Joystick > Balance Rotation Power**.
3. Select **Off-Idle REV/FWD Ratio**.

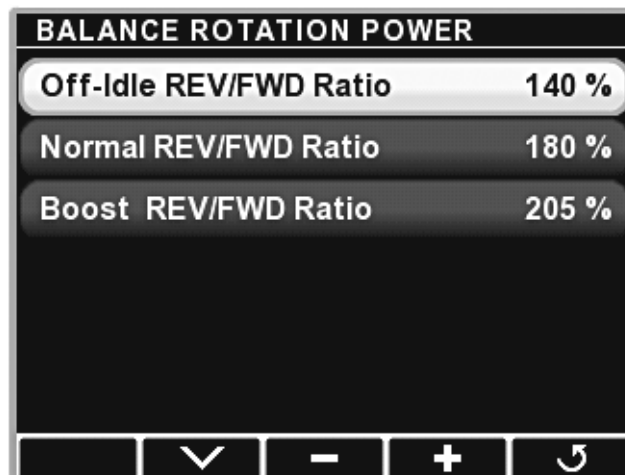

Figure 2-10.

4. Rotate the joystick clockwise only enough to engage gears.
 - a. If the boat moves aft while rotating, press – to decrease the ratio. If it moves forward, press + to increase the ratio.
 - b. Press **Save**.
 - c. Repeat until the boat rotates on the spot with no fore/aft movement. The final value should lie between 100% and the **Normal Rev/FWD Ratio** value.

STEP 2

1. Bring the boat to a stop with boost mode off.
2. Navigate to **Dealer Menu > Initial Setup > Joystick > Sideways Rudder Angle**.
3. Select **Off-Idle Rudder Angle**.

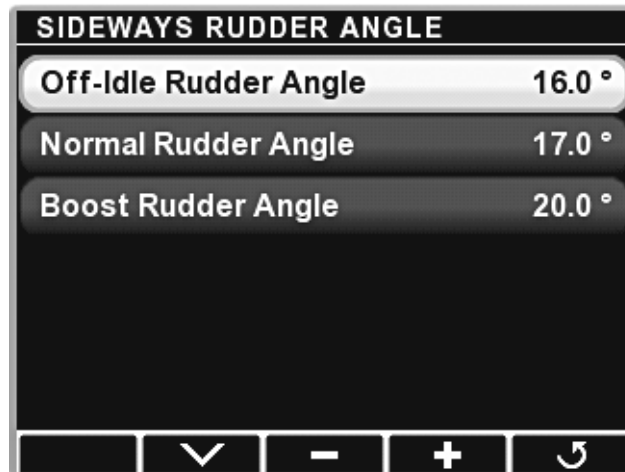

Figure 2-11.

4. Move the joystick sideways to port only enough to engage gears.
 - a. If the boat rotates clockwise as it starts to move, press – to decrease the angle. If it rotates counterclockwise, press + to increase the angle.

Note: the boat will rotate counterclockwise as it gains speed. This is normal - our objective is to remove rotation during initial movement.
 - b. Press **Save**.
 - c. Repeat until the boats initial movement is directly sideways.

STEP 3

1. Bring the boat to a stop with boost mode off.
2. Navigate to **Dealer Menu > Initial Setup > Joystick > Balance Sideways Power**.
3. Select **Off-Idle REV/FWD Ratio**.

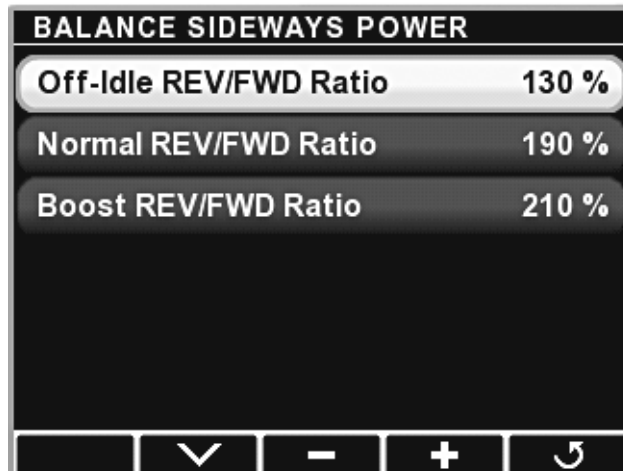

Figure 2-12.

4. Move the joystick sideways to port only enough to engage gears.
 - a. If the boat moves aft, press – to decrease the ratio. If it moves forward, press + to increase the ratio.
 - b. Press **Save**.
 - c. Repeat until the boat rotates on the spot with no fore/aft movement. The final value should lie between 100% and the **Normal Rev/FWD Ratio** value.

2.8.2 Settings

There are several SeaStation parameters and they are not intended to be changed in a typical installation – they are available for special cases.

All parameters are accessible through the CANtrak at **Dealer Menu > Devices > Main Joystick > Configuration > SeaStation > General Settings**.

If there are multiple joysticks, parameters must be changed in each of them.

SeaStation Parameters		
Name	Function	Default Value
Shift Out Of Gear RPM	SeaStation will not shift out of gear if engine RPM is above this value	900 RPM
Shift Into Of Gear RPM	SeaStation will not shift into gear if engine RPM is above this value	900 RPM
Position Error For Warning	SeaStation will sound an alarm if target position and actual position differ by this value	12 meters
Heading Error For Warning	SeaStation will sound an alarm if target heading and actual heading differ by this value	45°

Table 2-2. SeaStation Parameters.

2.8.3 Sea Trial

WARNING

ALWAYS WEAR A PFD AND CONNECT THE ENGINE LANYARD(S) TO THE OPERATOR DURING SEA TRIAL.

WARNING

PROPELLER INJURY HAZARD. SEASTATION TURNS PROPELLERS AUTOMATICALLY. THIS COULD INJURE SOMEONE IN THE WATER. MAKE SURE NO ONE IS IN OR ENTERS THE WATER.

A basic sea trial of SeaStation is required to confirm good performance. SeaStation has three modes – each mode should be trialed.

In light to moderate conditions, engage each mode and confirm:

1. No faults are thrown
If faults are frequently thrown, you may need to increase the error threshold for triggering the fault. See section 2.8.2
2. Engine activity is reasonable
If shifting seems hard, you may need to decrease the shift in / shift out thresholds. See section 2.8.2.
3. POSITION MODE holds position to within roughly 3 meters and 10°
4. HEADING MODE holds heading to within roughly 10°

See section 3.4 for tips on improving SeaStation performance.

If performance issues persist, contact SeaStar technical support.

2.9 Troubleshooting Guide

WARNING

WHENEVER, IN THE FOLLOWING TEXT, A SOLUTION CALLS FOR REMOVAL FROM VESSEL AND/OR DISMANTLING OF STEERING SYSTEM COMPONENTS, SUCH WORK MUST ONLY BE CARRIED OUT BY A QUALIFIED MARINE HYDRAULIC MECHANIC. SEASTAR SOLUTIONS OFFERS THE FOLLOWING AS A GUIDE ONLY AND IS NOT RESPONSIBLE FOR ANY CONSEQUENCES RESULTING FROM INCORRECT DISMANTLING OR REPAIRS.

Optimus SeaStation will provide years of safe reliable performance with a minimum of service if properly commissioned.

Most faults occur when the installation instructions are not followed and usually show up immediately. Listed below are the most common faults encountered and their likely cause and solution.

FAULT	CAUSE	SOLUTION
1. Joystick lost communication with GPS receiver	GPS-Compass is not communicating. License is incorrect.	Confirm all connections are in place. Confirm GPS is connected to correct network (Optimus CAN2). Confirm license is correct. See section 2.7 for details.
2. Joystick lost communication with heading sensor	GPS-Compass is not communicating. License is incorrect.	Confirm all connections are in place. Confirm GPS is connected to correct network (Optimus CAN2). Confirm license is correct. See section 2.7 for details.
3. GPS data invalid	No GPS-Compass position fix. GPS-Compass is malfunctioning.	Wait for GPS to acquire satellites. Move away from tall buildings and bridges. Mount GPS with good sky visibility. Contact SeaStar technical support.
4. Heading data invalid	No GPS-Compass position fix. GPS-Compass is malfunctioning.	Wait for GPS to acquire satellites. Move away from tall buildings and bridges. Mount GPS with good sky visibility. Contact SeaStar technical support.

FAULT

5. Significant position change detected

CAUSE

Joystick is insufficiently tuned.
Conditions are too strong.

SOLUTION

Retune joystick. See Book 65.
Some conditions may be too strong for position holding
The error threshold to throw this fault can be increased. See section 2.8.2.

6. Significant heading change detected

Joystick is insufficiently tuned.
Conditions are too strong.

Retune joystick. See Book 65.
Some conditions may be too strong for position holding
The error threshold to throw this fault can be increased. See section 2.8.2.

3.0 USER

3.1 Overview

SeaStation is an automatic vessel positioning system. SeaStation can control your vessel's position, heading, or both.

⚠ DANGER

PROPELLER INJURY HAZARD. WHEN SEASTATION IS ENGAGED:

- **Propellers turn automatically**
- **This could injure someone in the water**
- **The boat will suddenly move in any direction**
- **It is NOT SAFE to be in the water near the boat**
- **DO NOT enter the water or position yourself where you could fall in to the water due to sudden boat movement.**
- **The operator is still responsible for safely manning the vessel. This includes keeping passengers from entering the water as well as watching for oncoming boats, swimmers, or other objects.**

3.2 SeaStation Operation

3.2.1 SeaStation Modes

SeaStation has two modes that can be combined for a third mode. The joystick has a button and LED for the two primary modes.

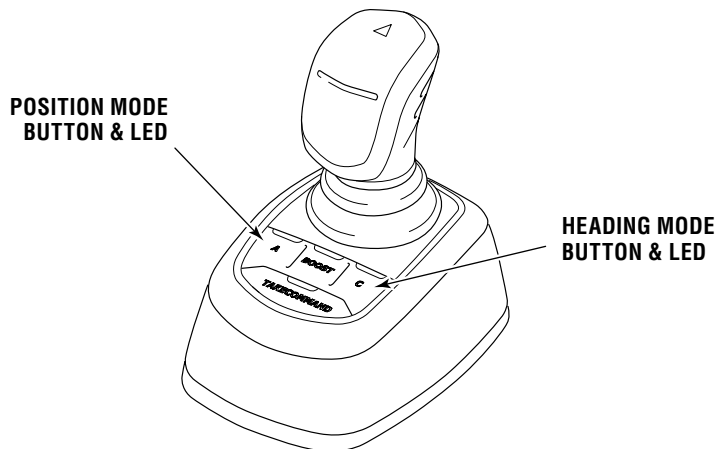

Figure 3-1. Joystick.

The modes function as follows:

1. POSITION MODE

- This mode automatically controls the vessel's position and lets heading drift freely.
- The **A** button engages/disengages POSITION MODE.
- A flashing LED means engagement needs to be confirmed on the display.
- A solid LED means POSITION MODE is engaged.

2. HEADING MODE

- This mode automatically controls the vessel's heading and lets position drift freely.
- The **C** button engages/disengages HEADING MODE
- A flashing LED means engagement needs to be confirmed on the display.
- A solid LED means HEADING MODE is engaged.

3. POSITION and HEADING MODE

- POSITION and HEADING modes can be combined for complete vessel control.
- The individual modes can be engaged separately or at the same time.

3.2.2 How to Engage and Disengage SeaStation

⚠ DANGER

ENGAGING SEASTATION CAUSES PROPELLERS TO TURN AUTOMATICALLY. THIS COULD INJURE SOMEONE IN THE WATER. IT IS THE OPERATOR'S RESPONSIBILITY TO MAKE SURE NO ONE IS IN THE WATER OR ENTERS THE WATER. IF SOMEONE ENTERS THE WATER, PULL ALL ENGINE LANYARD(S).

NOTICE

SeaStation requires a GPS fix. In some conditions, this may require a few minutes after power on.

Follow these steps to engage SeaStation:

- 1.** The joystick must be in command of the vessel.
- 2.** Press button(s) corresponding to desired mode(s) – see section 3.2.1.
- 3.** A warning will pop up on the display alerting you to the possible hazards of SeaStation.
- 4.** The LED(s) of selected mode(s) will be flashing.
- 5.** Press **Engage** on display to confirm the warning and engage the selected mode(s).
- 6.** The LED(s) of the selected mode(s) will be solid.

⚠ WARNING

SEASTATION POSITIONS THE VESSEL IN A GENERAL AREA. ONLY ENGAGE SEASTATION IF YOUR VESSEL IS A SAFE DISTANCE FROM SURROUNDING OBJECTS SUCH AS DOCKS OR BUOYS.



Figure 3-2. SeaStation Engagement Screen.

Once SeaStation is engaged, POSITION MODE and HEADING MODE can be toggled on and off at any time without deactivating SeaStation. For example, if you were to engage POSITION MODE, you could later add on HEADING MODE. Target position or heading is captured either when Engage is pressed on the display, or when the respective mode is toggled on while SeaStation is already active.

Only when both modes are off is SeaStation fully disengaged – re-engagement requires confirmation on the display again.

SeaStation is disengaged if:

- Both modes are turned off
- The joystick is moved
- Command is transferred to another joystick or control head

3.2.3 Standby Mode

If SeaStation is active, grabbing the joystick enters manual mode and forces SeaStation into standby. SeaStation can be resumed by pressing **Engage** on the CANtrak. Position and heading targets will be re-acquired.

3.2.4 Heading Bump

When HEADING MODE is active, the target heading can be adjusted without disengaging SeaStation. Simply press the **Heading** button on the display run screen and follow the screen information.

For large target heading changes (e.g. greater than 45°) it is recommended that you manually adjust the heading using the joystick then re-engage SeaStation.



Figure 3-3. Heading Bump Screen.

3.3 Station Transfer

Transferring to another station functions as it does in normal joystick use. SeaStation is disengaged when control is transferred and is not automatically resumed when control returns.

⚠ WARNING

NEVER LEAVE THE ACTIVE HELM WHILE SEASTATION IS ENGAGED. ALWAYS DISENGAGE SEASTATION PRIOR TO STATION TRANSFER OR HAVE ANOTHER OPERATOR TAKE COMMAND AT THE ALTERNATE STATION.

3.4 SeaStation Tips

WARNING

SEASTATION POSITIONS THE VESSEL IN A GENERAL AREA. ONLY ENGAGE SEASTATION IF YOUR VESSEL IS A SAFE DISTANCE FROM SURROUNDING OBJECTS SUCH AS DOCKS OR BUOYS.

The following are tips on how to get best results from SeaStation:

- **Grab the joystick at any time for immediate control (This will disengage SeaStation).**
- SeaStation acquires your target position or heading when **Engage** is pressed on the display.
- POSITION MODE and HEADING MODE can be toggled on and off at any time while SeaStation is active. Targets will be re-acquired upon engagement.
- Align your vessel stern to wind/current to reduce engine activity.
- If you don't know which way to align the boat, use POSITION MODE to let the boat find a stable heading then engage HEADING MODE.
- If engines are working very hard, try bumping the target heading so the boat is closer to parallel with wind/current – see section 3.2.4.
- POSITION MODE on its own requires less engine activity than when combined with HEADING MODE. Vessel heading usually changes minimally in POSITION MODE thus it is recommended for most applications.

3.5 SeaStation Faults

3.5.1 Drift Faults

If the vessel drifts too far from its target position or heading, the display will alarm:



Figure 3-4. SeaStation Drift Faults.

Drift alarms are usually a result of either:

- 1.** The boat is not positioned well relative to current conditions. Try aligning your boat to be more parallel with wind or current.
- 2.** Conditions are simply too strong for SeaStation. You may need to move to a more sheltered area.

In many cases, drift faults can be prevented by using POSITION MODE on its own. It is more difficult for SeaStation to hold position and heading at the same time. If heading is not truly required, disengage this mode.

3.5.2 GPS-Compass Faults

There are two types of GPS faults:

- 1. Communication Fault**
If a communication fault occurs, contact technical support for assistance.
- 2. Signal Fault**
Often a signal fault is due to the GPS-Compass having no signal or a poor quality signal. Try moving to an area with better sky visibility, or give the system more time to track and acquire satellites.

3.6 Maintenance and Replacement Parts

Following the routine maintenance schedules outlined below will ensure years of service from your Optimus SeaStation System, as well as keep you and your passengers safe from the dangers that are present on and off the water.

NOTICE

Follow all maintenance procedures in Book 65.

3.6.1 Owner(s) (End Users)

Prior to every use:

1. Inspect all electrical cables for wear.
2. Verify that no alarms or warnings are shown on the CANtrak display.

WARNING

DO NOT OPERATE BOAT IF ANY COMPONENT IS NOT IN PROPER WORKING CONDITION.

3.6.2 Qualified Marine Mechanic

After the first 20 hours, then every 100 hours or 6 months thereafter (whichever comes first).

1. All points noted above.
 2. Check for signs of corrosion. If corrosion is present contact your dealer or SeaStar Solutions.
 3. Check all electrical cables for chafing and wear.
-

3.6.3 Replacement Parts

See Book 65 for details on replacement parts within your steering and joystick systems.

EPSK1600 – GPS-Compass Kit

A new SeaStation license key will be provided with the kit — the system must be updated with this new license. See section 2.7.

This page left intentionally blank.

4.0 WARRANTY

4.1 Statement of Limited Warranty

We warrant to the original retail purchaser that **Marine Canada Acquisition Inc. DBA SEASTAR SOLUTIONS** (herein forward referred to as **SeaStar Solutions**) products have been manufactured free from defects in materials and workmanship. This warranty is effective for two years from date of purchase, excepting that where **SeaStar Solutions** products are used commercially or in any rental or income producing activity, then this warranty is limited to one year from the date of purchase.

We will provide replacement product without charge, for any **SeaStar Solutions** product meeting this warranty, which is returned (freight prepaid) within the warranty period to the dealer from whom such product were purchased, or to us at the appropriate address. In such a case **SeaStar Solutions** products found to be defective and covered by this warranty, will be replaced at **SeaStar Solutions'** option, and returned to the customer.

The above quoted statement is an extract from the complete **SeaStar Solutions** products warranty statement. A complete warranty policy is available on the **SeaStar Solutions** website:

<http://www.seastarsolutions.com/support-2/warranty-2/seastar-solutions-warranty/>

4.2 Return Goods Procedure

Prior to returning product to **SeaStar Solutions** under warranty, please obtain a *Return Goods Authorization number* (claim number).

Be sure to label the goods with:

- a) the name and address of the sender, and
- b) the return goods authorization number (claim number)

Please address the returned goods as follows:

From U.S.A.
RGA # ?
SeaStar Solutions
c/o UPS-SCS
19308 70th Ave S.
Kent, WA 98032

From Canada
RGA # ?
SeaStar Solutions
3831 No. 6 Road
Richmond, B.C.
Canada V6V 1P6

Technical Support

Phone: 604-248-3858

Email: seastar@seastarsolutions.com

Hours: Monday to Friday 05:00 – 15:30 PST

Web: www.seastarsolutions.com

IMPORTANT: License key to activate
SeaStation. DO NOT LOSE.



SEASTAR
SOLUTIONS®

SEASTAR SOLUTIONS
3831 NO. 6 ROAD
RICHMOND, B.C.
CANADA V6V 1P6

FAX 604-270-7172

www.seastarsolutions.com

ISO 10592



© 2016 MARINE CANADA ACQUISITION INC.
DBA SEASTAR SOLUTIONS

PRINTED IN CANADA 02/18

Please scan
this QR code
and watch our
latest **Boating**
Safety video.



FORM NO. 682175 REV. C

